

PARAGON VAV d

Installation – Commissioning – Maintenance

17/01/2023
Art. 942428072

Contents

Application area.....	2
General.....	2
Contents.....	2
Protective equipment.....	2
Electrical safety.....	2
Handling.....	2
Installation.....	2
Cleaning.....	2
Cleaning of electrical components.....	2
Service/maintenance.....	2
Environment and waste disposal.....	2
Product warranty.....	2
Dimensions and weights.....	3
Installation.....	4
Size of the opening.....	4
Suspension.....	5
Connection - Water.....	7
Connection - air.....	9
Supply and extract air kit.....	10
Installation, grille.....	11
Connections control equipment.....	12
Room controller, LOCUS.....	14
Sensor module.....	15
Maintenance.....	16

Symbols

Warning/Caution!



See also the following documents at www.swegon.com:

- PARAGON VAV Product datasheet
- VAV Modbus
- Comfort modules operation and maintenance (IOM)
- LOCUS Product datasheet
- LOCUS Instructions for Use (IOM)

Application area

The product is a comfort module designed for demand-controlled climate indoors.

The product is used to ventilate, cool and heat premises exactly as needed.

The product may not be used for anything other than its intended use.



General

Read through the entire instructions for use before you install/use the product and save the instructions for future reference. It is not permissible to make changes or modify this product other than those specified in this document.

Contents

1 x PARAGON VAV

1 x Instructions for use



Protective equipment

Always use appropriate personal protective equipment for the work in question, in the form of gloves, respirators, protective glasses and helmets during handling, installation, cleaning and service/maintenance.



Electrical safety

Permitted voltage, see Electrical data.

It is not permissible to insert foreign objects into the product's contactor connections or ventilation openings; risk for short circuiting.

24 V isolation transformer to be connected should comply with the provisions of IEC 61558-1.

Cable sizing must be carried out for cabling between the product and the power supply source.

Disconnect the power supply when working on products that are not required to run.

Always follow the local/national rules for who shall be permitted to carry out this type of electrical installation.

Handling

Always use appropriate transport and lifting devices when the product is to be handled to reduce ergonomic loads.

The product must be handled with care.

Installation

- Moist, cold and aggressive environments must be avoided.
- Assemble the product according to this instruction and applicable industry regulations.
- Install the product for easy access during service/maintenance.
- Avoid installing the product near a heat source.
- Check to make sure that the product does not have any visible defects.
- Check that the product is properly secured after it has been installed.
- Secure cables with cable ties.
- Check that all cables are properly secured in place after installation.

Cleaning

Ideally the product should be cleaned twice a year by vacuuming the coil to remove loose dust.

In fibre-dense environments such as hotels, an initial cleaning is recommended, about three months after use, as new textiles usually release more fibres. Thereafter, cleaning is recommended at an interval of one to two times per year.

A simple visual inspection of connections is recommended when cleaning.

For cleaning grilles and other painted surfaces: Avoid aggressive cleaning agents which may harm painted surfaces. Normally a mild soap or alcohol solution is fully adequate for cleaning. See also the maintenance section.

Cleaning of electrical components

- If needed, use a dry cloth to clean the components.
- Never use water, detergent and cleaning solvent or a vacuum cleaner.

Service/maintenance

- In connection with a service, mandatory ventilation inspection or cleaning of the ventilation system, check that the general condition of the products looks ok. Pay particular attention to the suspension, cables and that they sit firmly in place.
- It is not permissible to open or repair electrical components.
- If you suspect that the product or a component is defective, please contact Swegon.
- A defective product or component must be replaced by an original spare part from Swegon.

Environment and waste disposal

Help to protect the environment by ensuring correct disposal of the packaging and use the products in accordance with applicable environmental regulations.

Product warranty

The product warranty or service agreement will not be in effect/will not be extended if: (1) The product is repaired, modified or changed, unless such repair, modification or change has been approved by Swegon AB; or (2) the serial number on the product has been made illegible or is missing.

Dimensions and weight

Weight

PARAGON VAV 800

Length mm	Type	Dim. Ø	Dry weight* (kg)		Water volume (l)	
			Without grille	incl. grille	cooling	heating
800 R	A	125	14.0	16.9	1.39	
800 L	A	125	14.0	16.9	1.38	
800 R	B	125	14.0	16.9	1.39	0.38
800 L	B	125	14.0	16.9	1.38	0.37
800 R	X	125	14.0	16.9	1.39	
800 L	X	125	14.0	16.9	1.38	

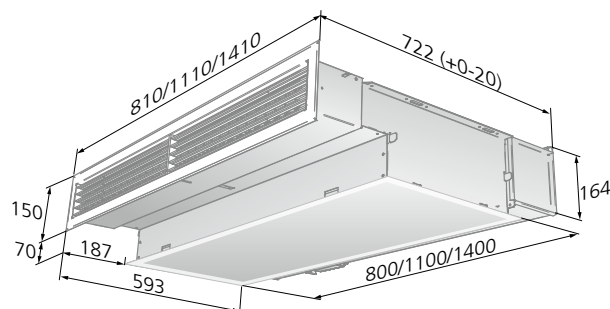

PARAGON VAV 1100

Length mm	Type	Dim. Ø	Dry weight* (kg)		Water volume (l)	
			Without grille	incl. grille	cooling	heating
1100 R	A	125	18.8	22.6	1.93	
1100 L	A	125	18.8	22.6	1.92	
1100 R	B	125	18.8	22.6	1.93	0.52
1100 L	B	125	18.8	22.6	1.92	0.51
1100 R	X	125	18.8	22.6	1.93	
1100 L	X	125	18.8	22.6	1.92	

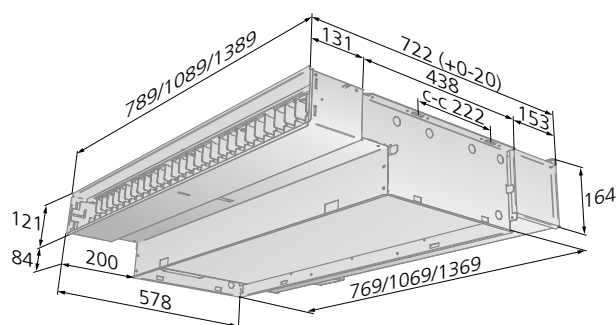

PARAGON VAV 1400

Length mm	Type	Dim. Ø	Dry weight* (kg)		Water volume (l)	
			Without grille	Incl. grille	cooling	heating
1400 R	A	125	23.0	27.6	2.47	
1400 L	A	125	23.0	27.6	2.46	
1400 R	B	125	23.0	27.6	2.47	0.65
1400 L	B	125	23.0	27.6	2.46	0.64
1400 R	X	125	23.0	27.6	2.47	
1400 L	X	125	23.0	27.6	2.46	

*Added weight for:
Control equipment: 0.84 kg

Installation

Size of the opening

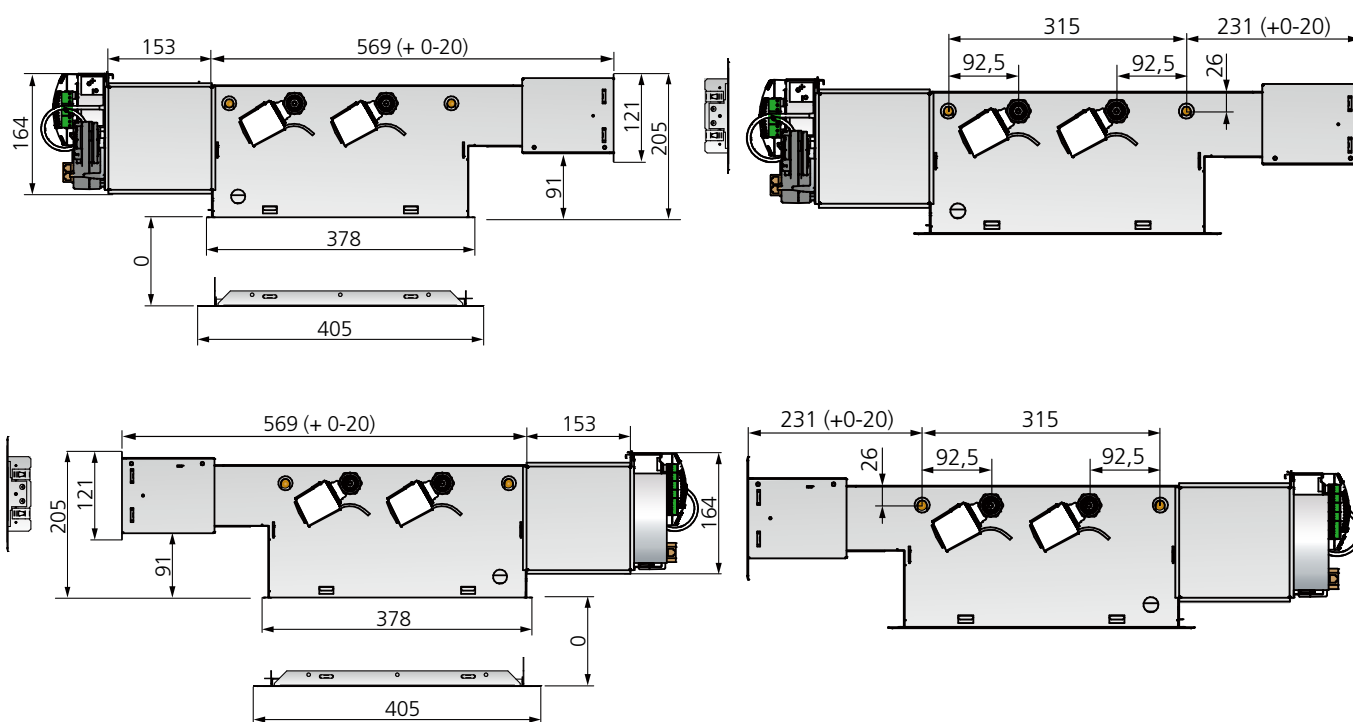
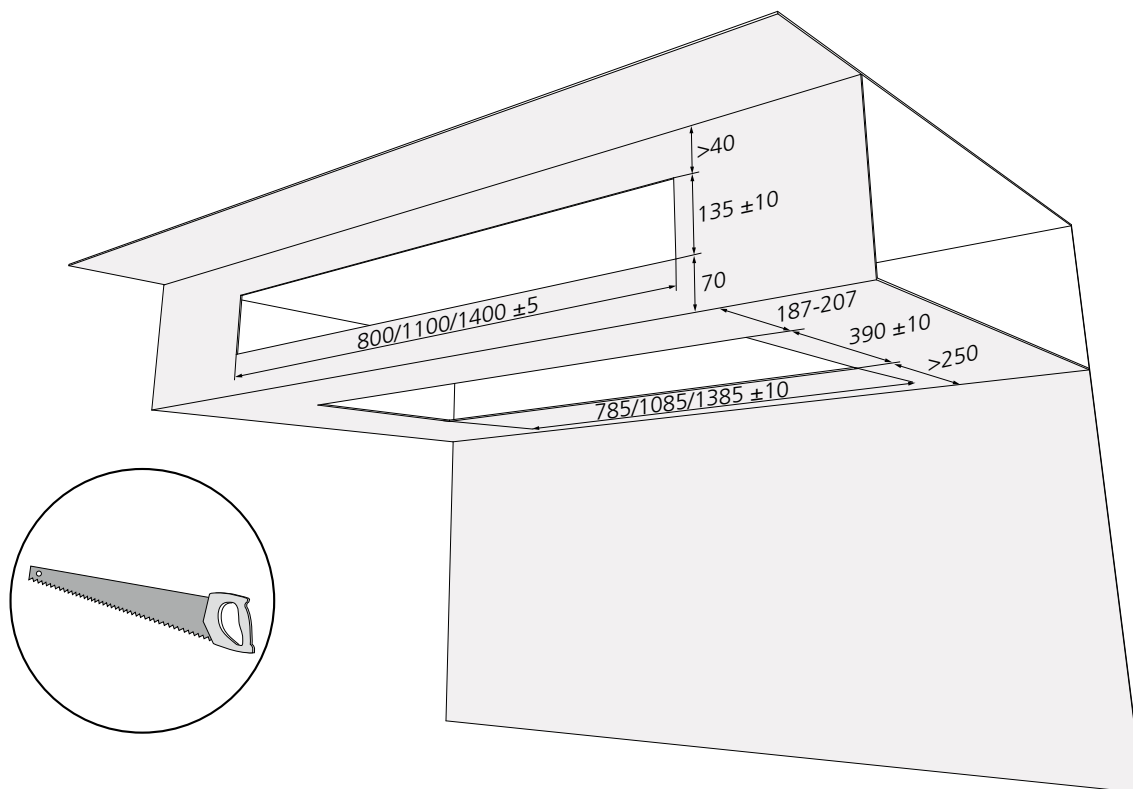

Suspension

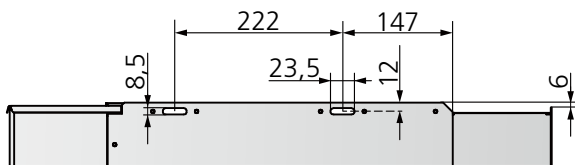
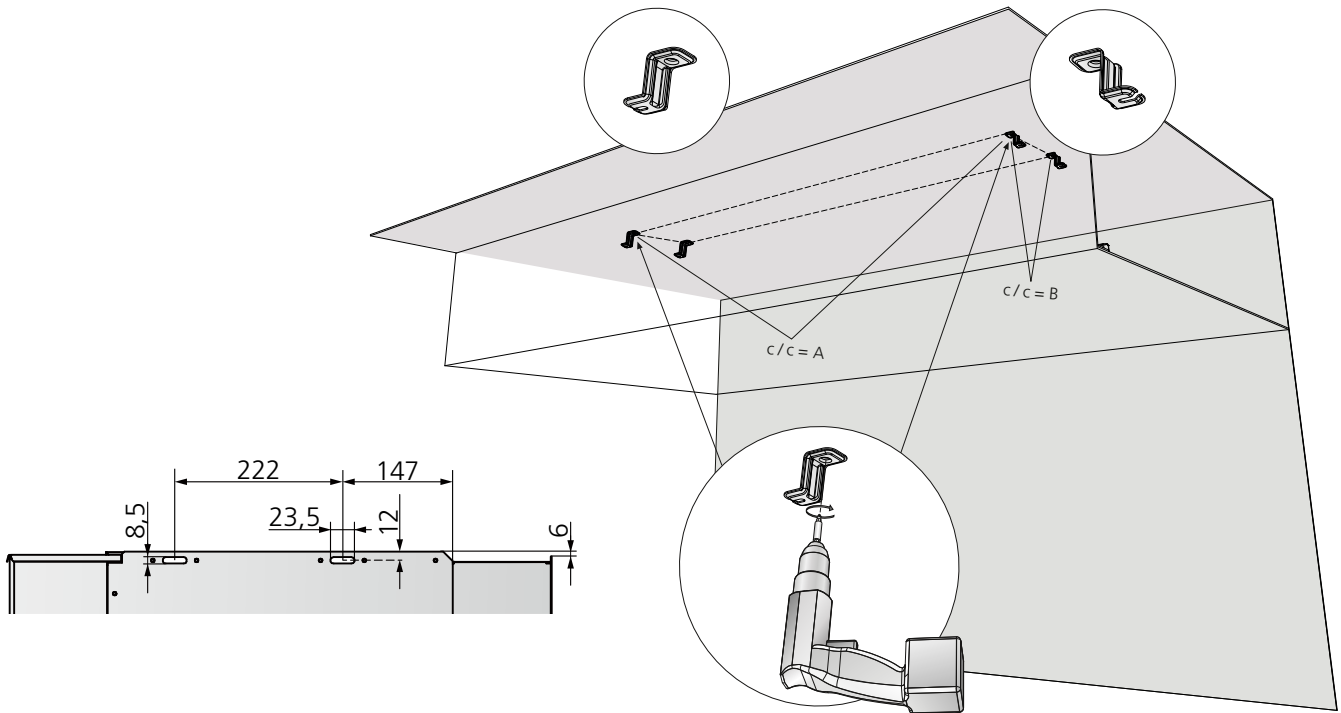

L	A	B
800	778	222
1100	1078	222
1400	1378	222

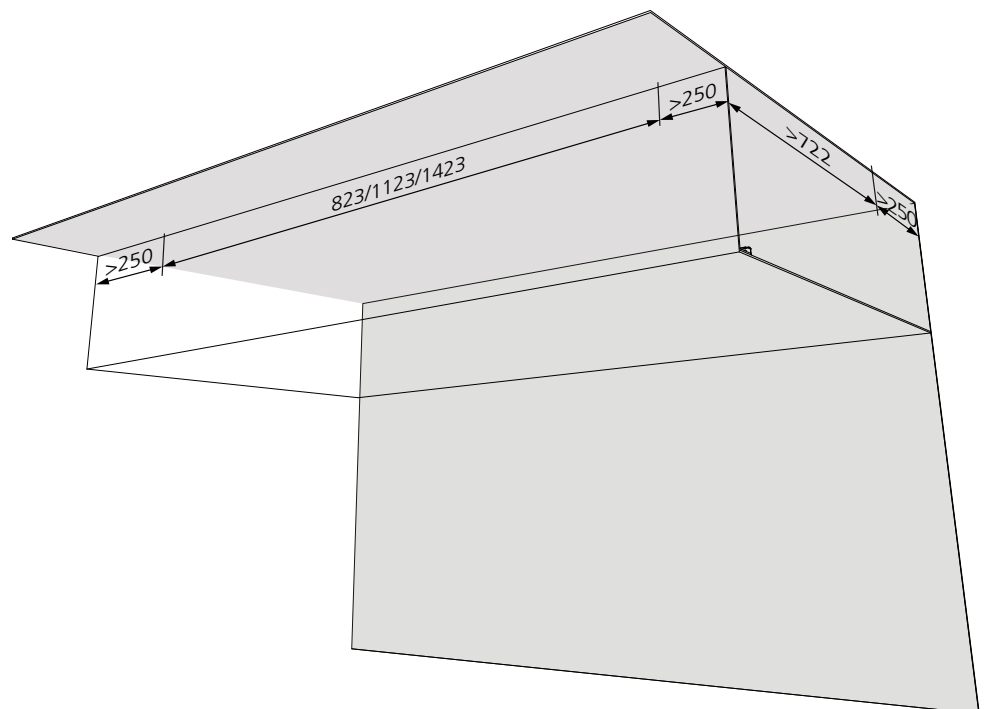
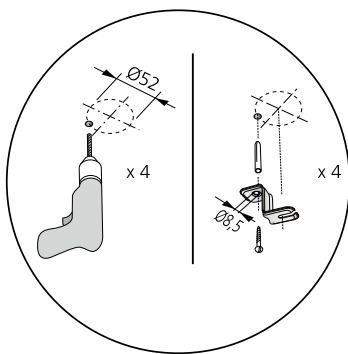

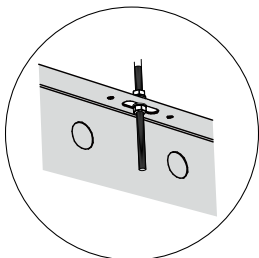
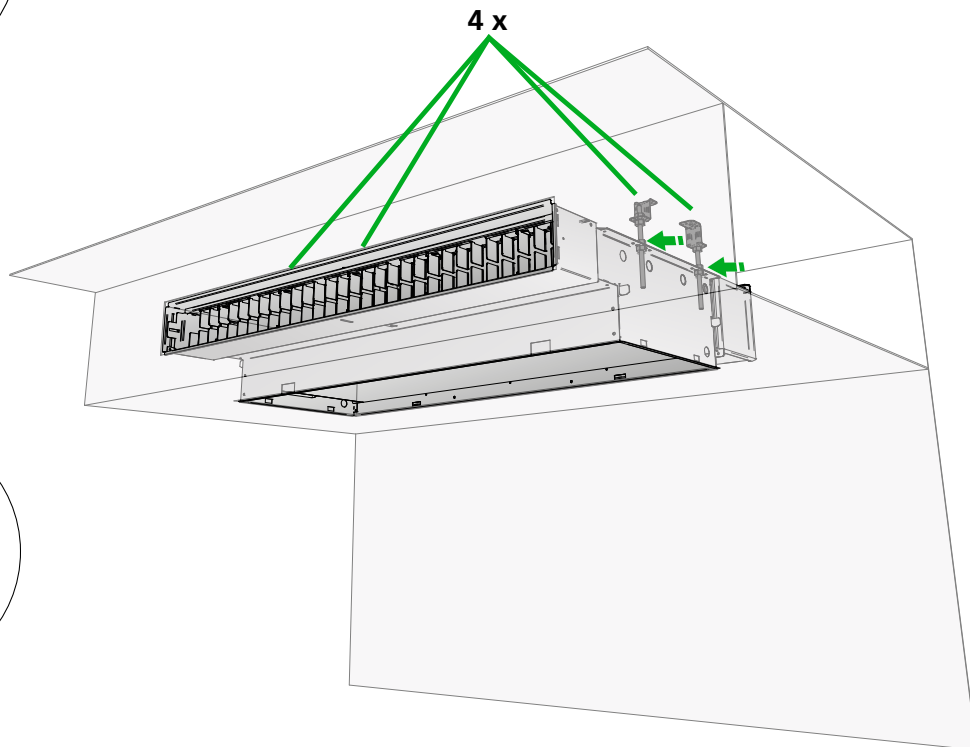
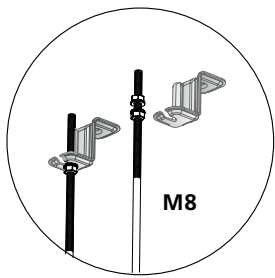
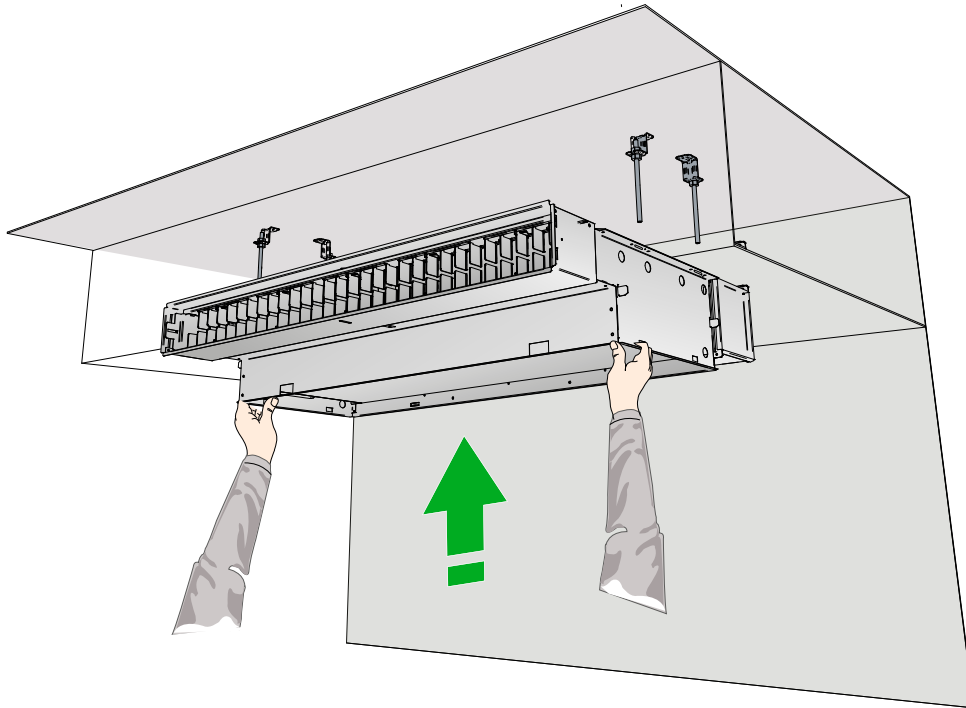

Connection - Water

Connection sizes

Standard variant with factory-fitted valves:

Length	Cooling	Heating
(mm)	Return	Return
800, 1100, 1400	DN15 male thread	DN15 male thread

Standard variant without factory fitted valves:

Length	Cooling	Heating
(mm)	Supply and return	Supply and return
800, 1100, 1400	plain pipe ends (Cu) Ø 12 x 1.0 mm	plain pipe ends (Cu) Ø 12 x 1.0 mm

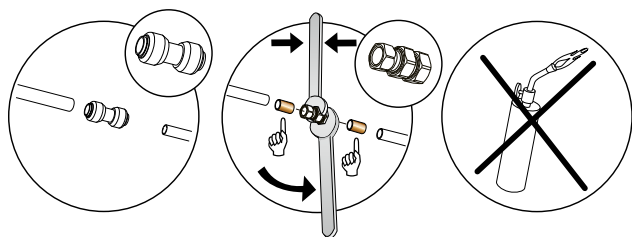

Note that compression ring couplings require support sleeves inside the pipes.

Connecting water

Connect the water pipes using push-on couplings or compression ring couplings.

Note that compression ring couplings require support sleeves inside the pipes. Do not use solder couplings to connect the water pipes. High temperatures can damage the unit's existing soldered joints.

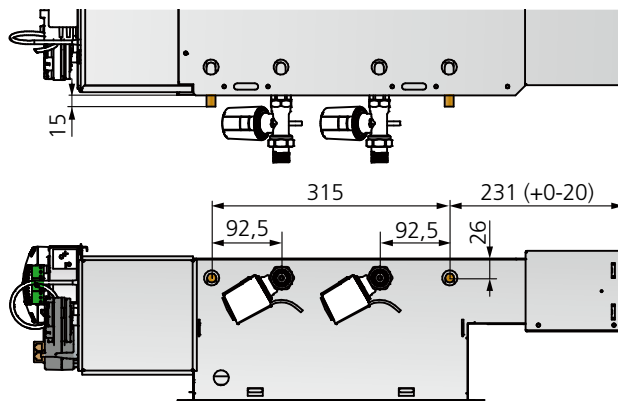

Water connection on the right-hand side "R"

Cooling and heating R. all sizes

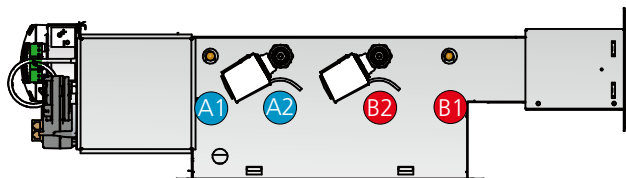

Cooling R, all sizes

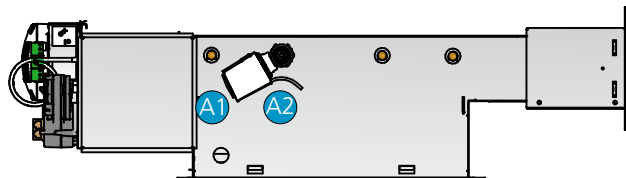

Water connection on right-hand side (R).

- A1 = Cooling water, supply
- A2 = Cooling water, return
- B1 = Heating water, supply
- B2 = Heating water, return

Water connection on the left-hand side "L"

Cooling and heating L. all sizes

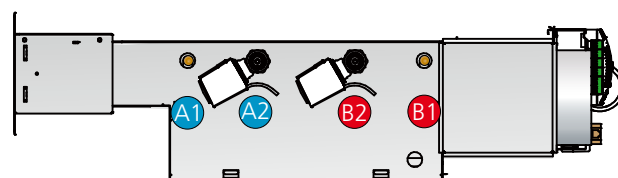

Cooling L, all sizes

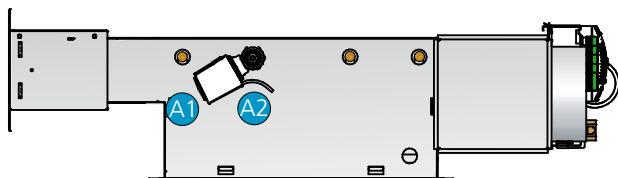

Water connection on left-hand side. (L).

- A1 = Cooling water, supply
- A2 = Cooling water, return
- B1 = Heating water, supply
- B2 = Heating water, return

Water connection at the rear edge "WB"

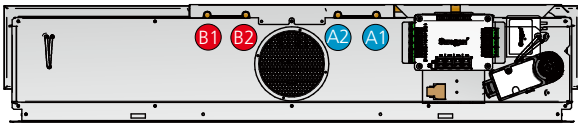

Water connection at the rear edge (WB).
 A1 = Cooling water, supply
 A2 = Cooling water, return
 B1 = Heating water, supply
 B2 = Heating water, return

Connection of CCO valve

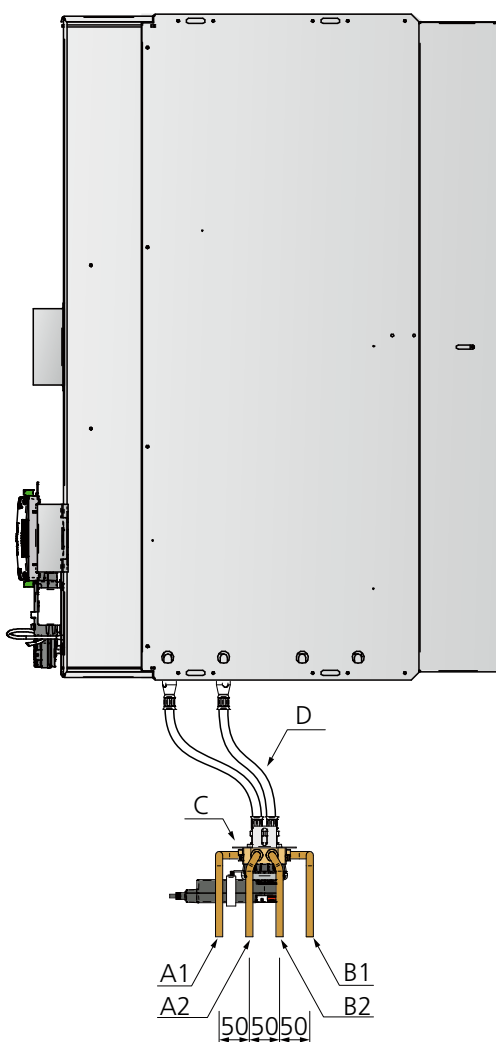

Water connection with CCO valve.
 A1 = Cooling water, supply
 A2 = Cooling water, return
 B1 = Heating water, supply
 B2 = Heating water, return
 C = CCO valve
 D = Flexible hose

Water quality

Swegon recommends water quality according to VDI 2035-2 for both the heating and cooling systems. In order to maintain the oxygen content in the water below the levels (<0.1 mg/l) prescribed in VDI 2035-2, it is recommended to install a vacuum degasser, particularly in the cooling system where it's more challenging to dissolved gas. It is also important that the pre-pressure in the expansion vessel is dimensioned according to EN-12828 for both the heating and cooling systems and that regular checks are made of the pre-pressure. The cooling and heating systems must be designed to prevent oxygen from entering the system, this is particularly important to consider when selecting flex hose, pipes and expansion vessels.

When the system is filled with fresh water, it has an oxygen content of approximately 8 mg/l, however, this oxygen is consumed quickly through corrosion processes and within a few days the oxygen in the water should be consumed. Nevertheless, it is important to avoid filling the system with fresh water unnecessarily.

Automatic deaerators are often installed to facilitate filling of the system. It is recommended that the automatic deaerators are turned off once the system has been fully vented to avoid these drawing in air in the system if the pre-pressure in the expansion vessel should drop.

Connection - air

All variants have the air connection $\varnothing 125$.

The standard variant has the air connection centred at the rear of the product for easy access from both ends and the rear.

The suite version, which is only available in 1400 mm length, has two parallel air connections at the rear, i.e. 2x $\varnothing 125$.

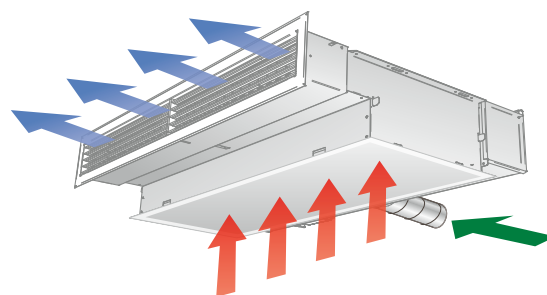

Standard, Rear view

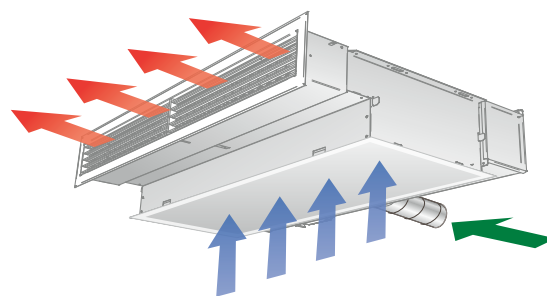
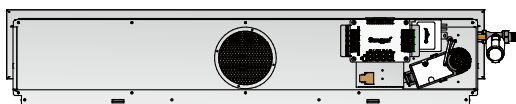

Suite, Rear view

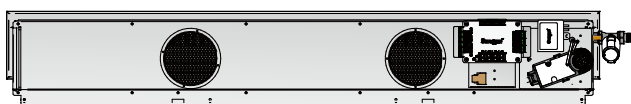

Connection dimensions, air

Variant	Length	Air connection	
	(mm)	1 x $\varnothing 125$	2 x $\varnothing 125$
1: Standard	800, 1100, 1400	Yes	No
2: Suite	1400	No	Yes

Supply and extract air kit

Supply air kit

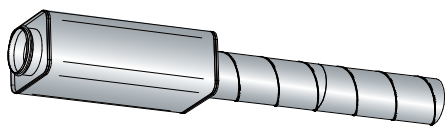

Extract air kit

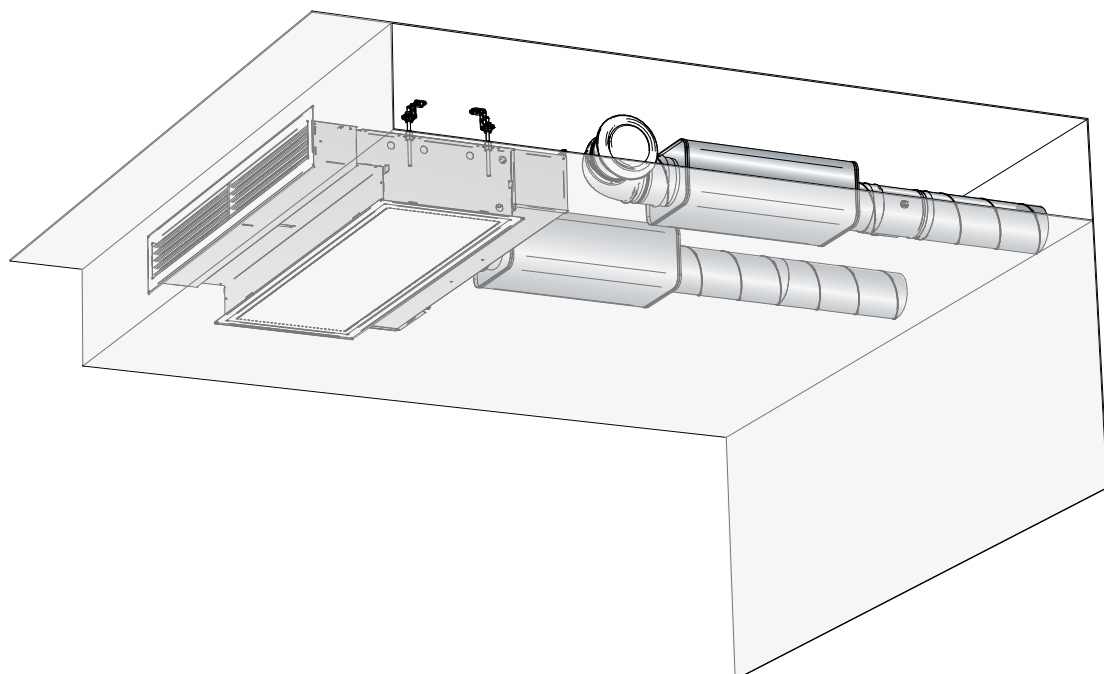
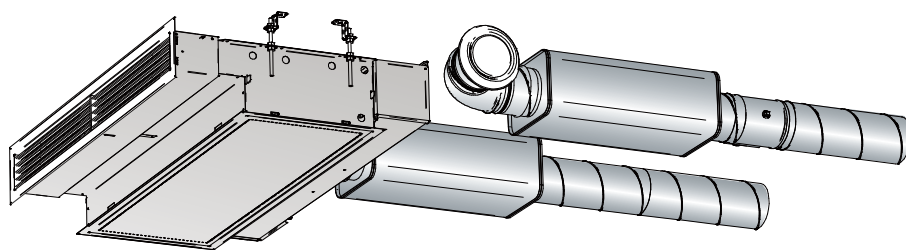
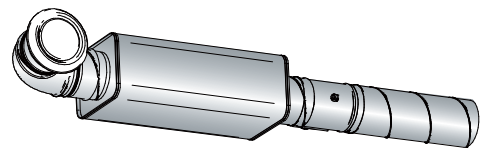

Installation, grille

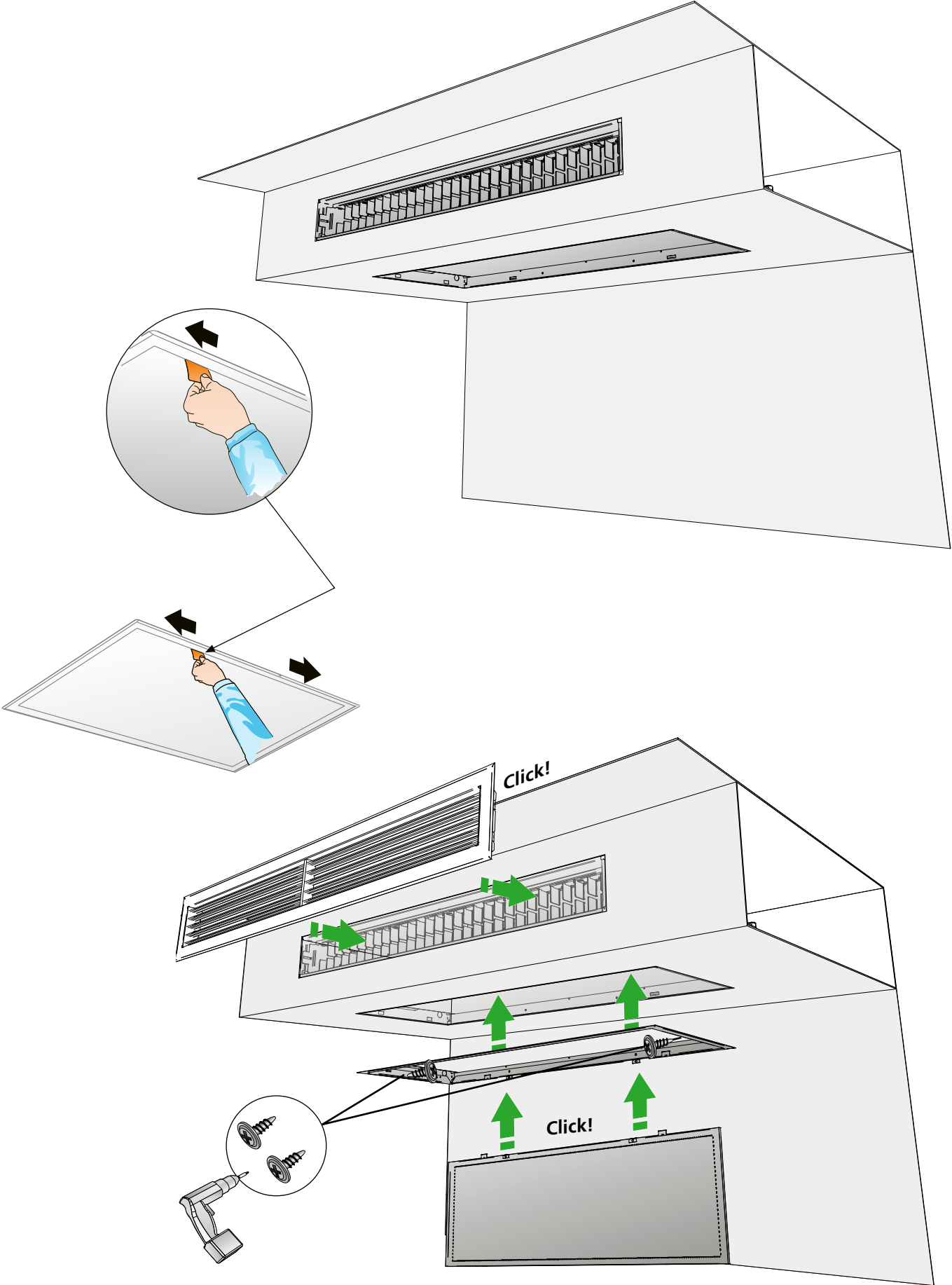

Connections control equipment

Wiring diagram for controller (URC1) with accessories

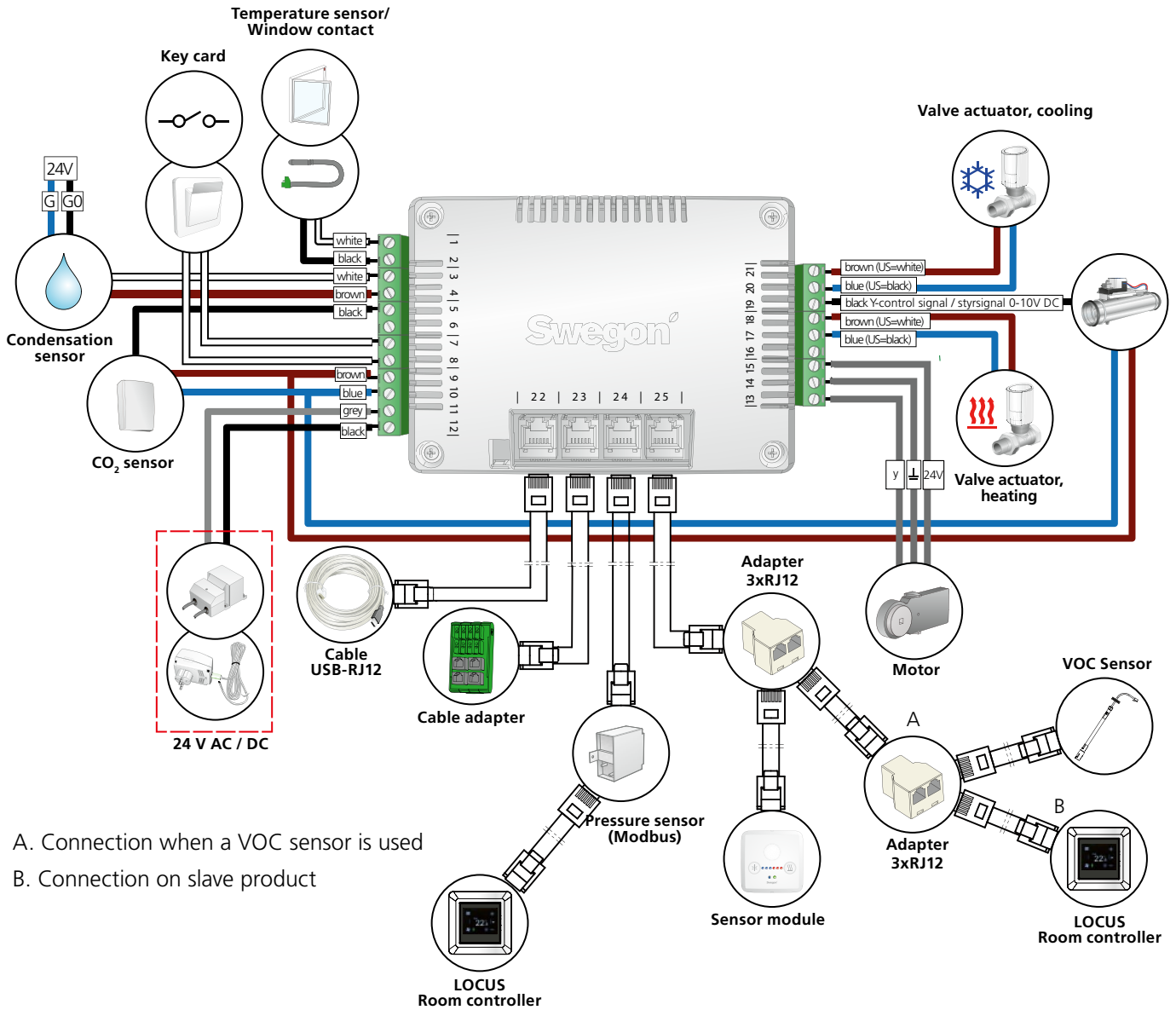

Controller outputs

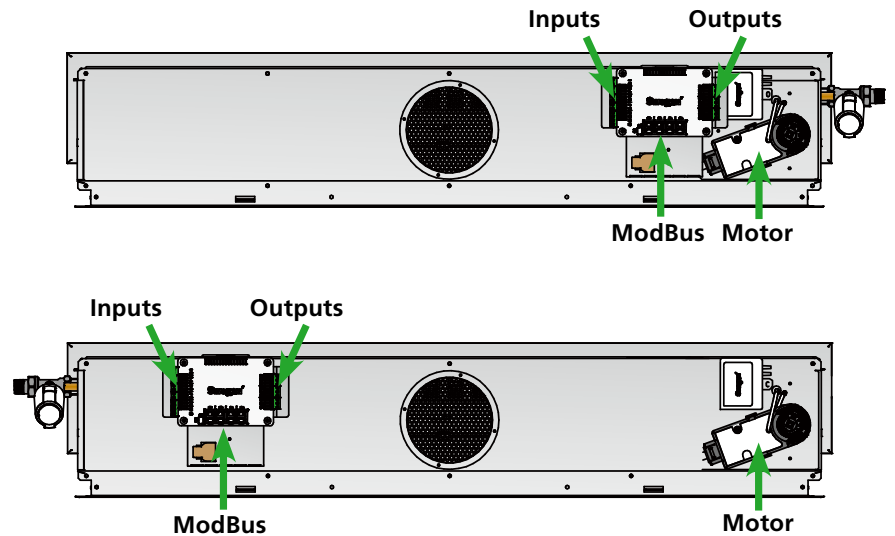
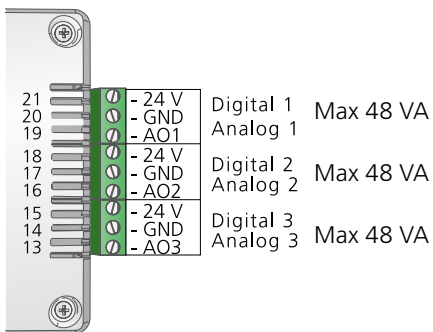

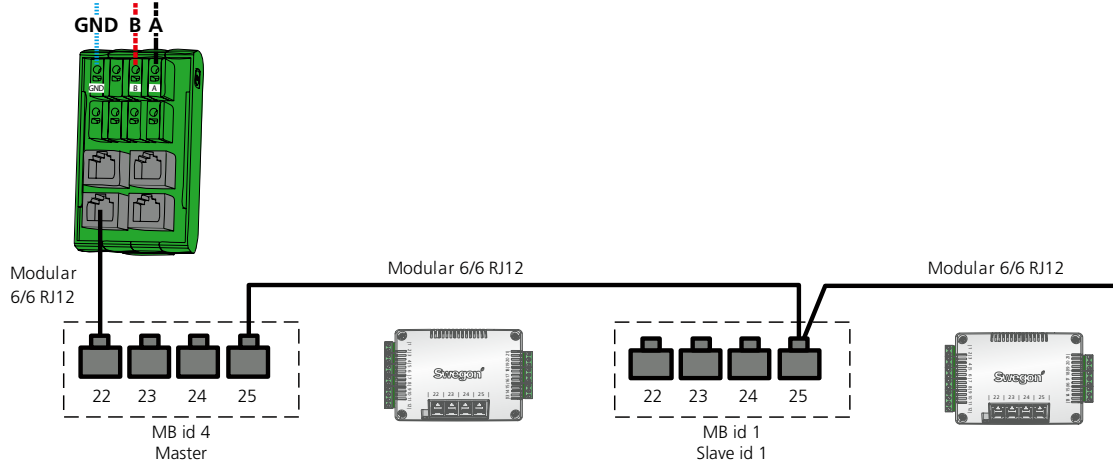
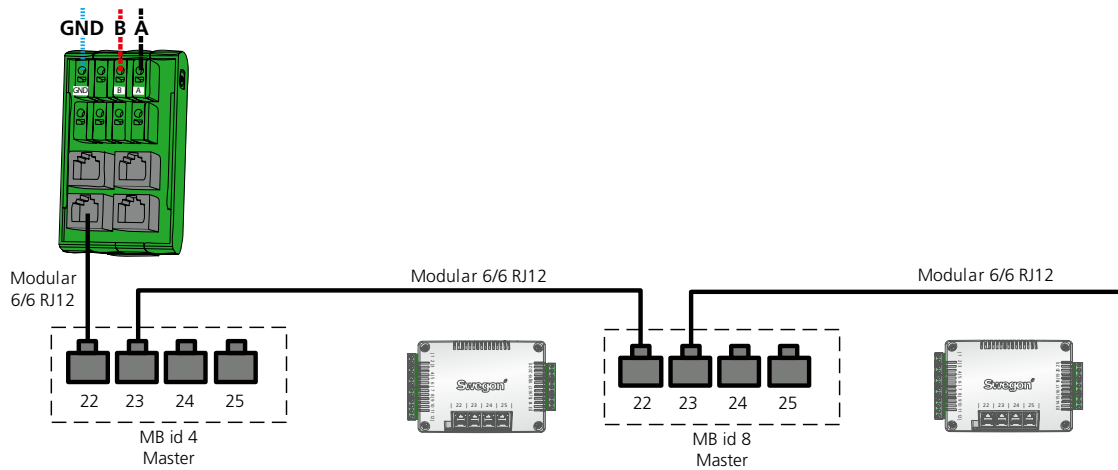
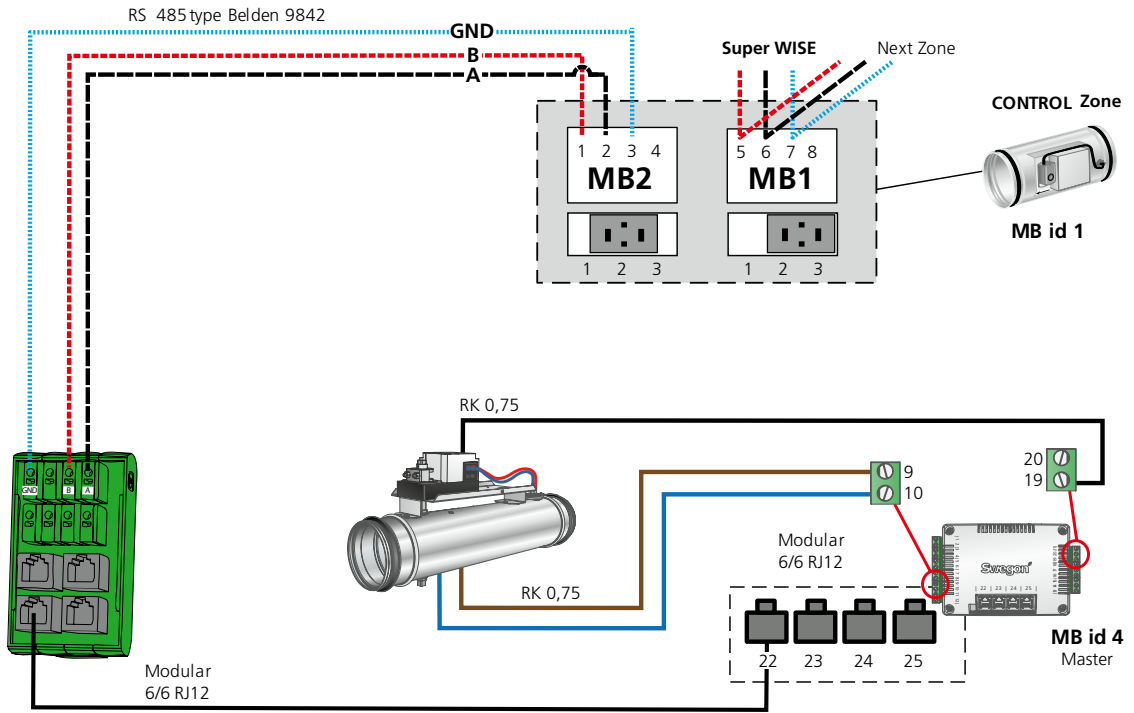

Room controller, LOCUS

Main menu and explanation of symbols

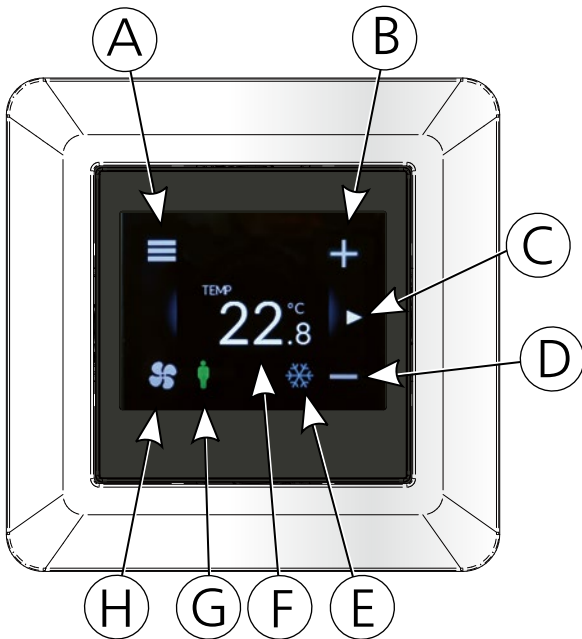

- A. menu
- B. increase
- C. swipe left to go to the next page
- D. decrease
- E. symbol showing ongoing cooling or heating
- F. shows programmed setpoint or measured temperature
- G. shows occupancy in the room
- H. press to activate boost flow

Technical data

Display	Capacitive touch TFT Display QVGA 2.3"
Screen resolution	320x240
Communication	Modbus RTU via RS-485
Temperature sensor	Internal 10K NTC sensor
Operating temperature	+5 ... +40°C
Degree of protection	IP20
Dimensions	88 x 88 x 35 mm
Operating voltage	12-40 VDC
Current requirement	0.5 W

Connection

LOCUS	Connection	Description
VDD	RJ12	12-40 VDC power supply
A+	RJ12	RS-485 bus connection
B-	RJ12	RS-485 bus connection
GND	RJ12	Earth for 12-40 VDC power supply
Memory card slot		The user panel's software can be updated via a Micro SD card

Standards and directives

The following standards have been observed:

EC Directive:	93/68/EEC
Low Voltage Directive:	2014/35/EU
Machinery Directive:	2006/42/EEC
EMC Directive:	2014/30/EU
RoHS Directive:	2002/95/EC
Vibrations:	EN-60721-3-3

Description of display

If the screen is in standby mode, it is activated again by clicking.

Display	Description	Explanation
	Display in standby mode	Activated with a click
	Active main menu	Increase/decrease the setpoint temperature by clicking on the + or - signs
	Activated boost mode	
	Swipe left for next page	Shows values from connected sensors
	Swipe right to go back to the main menu	

For more detailed information about LOCUS room controller. See documentation at www.swegon.com

- LOCUS Product datasheet
- LOCUS Instructions for Use (IOM)

Maintenance

