



ACOUSTICS

Highest comfort - free from disturbing sound and noise

Acoustic products from Swegon

Our aim is to make acoustics easy for you. Today, based on our vast experience of developing and manufacturing acoustic products, we have market-leading products with the highest performance.

With a wide range of different product types, sizes and fire ratings, you will quickly find a product that matches your project. Safe and easy!



CLA Sound attenuator mounted above a suspended ceiling in an office with PARASOL

Common to Swegon's different sound attenuators is a high level of sound attenuation combined with a low pressure drop and compact measurements. This saves fan energy, promotes simpler design, straight-forward installation and the best prerequisites for a silent and comfortable indoor climate.

Contents

To consider during project design.....	page 3	Sound attenuating exterior wall grilles.....	page 15
Sizing.....	page 4	Air transfer diffuser.....	page 16
Pressure drop.....	page 5	Accessories, Fire-resistance classes.....	page 17
Circular sound attenuators.....	pages 6-8	Supply and extract air kit.....	page 18
Rectangular sound attenuators.....	pages 9-14	Selection guide.....	page 19

To consider during project design

Sound in ventilation ducts

The most common sound in ventilation ducts include:

- Fan noise
- Throttling noise from dampers
- Air flow noise
- Cross-talk noise

In principle, a sound attenuator in a ventilation system is always needed in order to reduce the noise specified above and produce a good sound environment. We divide them up into two groups.

Unit sound attenuators

The primary task of a unit sound attenuator is to reduce fan noise. When selecting a unit sound attenuator, attention must also be paid to the pressure drop while bearing in mind the power consumption of the fan.

Duct sound attenuators

The duct sound attenuator has the task of reducing the flow and throttling noise in the duct system. It is usually used to remove noise from dampers and is placed between the damper and room.

How do Swegon's sound attenuators work?

Swegon's sound attenuators use porous mineral wool as the sound-absorbing material. When sound waves penetrate the mineral wool, parts of the sound energy are converted, by friction, to barely discernible heat.

The degree of sound attenuation obtained from an individual product is affected by the thickness of the mineral wool, air gaps and the length of the sound attenuator.

The sound attenuators are designed taking aerodynamic properties into consideration, to produce as good sound attenuation as possible with the least possible pressure drop for the passing air. This means that the fans in the system do not have to work so hard, which saves electricity.

CALMO, is frequently used as a unit sound attenuator



SORDO and CLA, are often used as duct sound attenuators

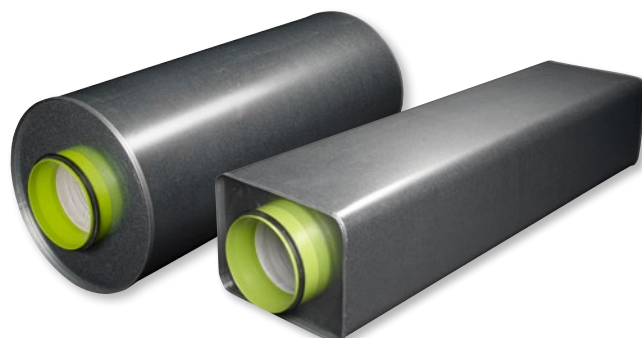

Three tips for a good acoustic indoor climate

- The basic rule for good acoustics is to try to attenuate the sound at source. In practice, this means that there should be a sound attenuator at each sound source in the ventilation system.
- For the best result, select an air handling unit that generates as little sound in the ducts and vibration to the surroundings as possible. Swegon's ranges of air handling units GOLD and SILVER with their aerodynamic well-designed fans reduce the risk of abnormal noise directly at source.
- Choose damper and room products that have a high air capacity and low sound level, so that sound attenuators are not fighting a losing battle. Swegon's dampers, diffusers and climate beams are an assured choice, as they are always designed and tested to minimise sound generation in the room.

Sizing

You can use Swegon's product selection program ProSilenzer in order to produce the right dimensions, sound attenuation and pressure drop for the sound attenuator in question.

The program is web-based and is available via Swegon's website. ProSilenzer is also available as a MagiCad plugin for AutoCAD and Revit.

Swegon ProSilenzer
2018-03-27

Project: [Empty] Customer: [Empty]

Your reference: [Empty] Our reference: [Empty] Date: 2018-03-27

Article name: **LARGO a-1436-1400-600-300** Position: **LB01**

Supply air

Quick facts
Remotely monitoring rectangular sound attenuator
Excellent acoustical characteristics
Very low pressure drop - acoustic baffles serve as guide vanes
Type approved, environmentally friendly sound attenuating material: ISOVER Cleanseal PLUS
ISOVER Cleanseal PLUS is cleanable using a wet method.
Available with cleaning cover
Available in a fire resistant insulated version with 50 mm thick mineral wool
Connection sizes ranging from 400x300 to 2000x2000 mm

General
The LB01 is an angle sound attenuator with aerodynamically designed baffle systems suitable for use both in ducts and in direct connection to ventilation units
Info text regarding a device in protob.

Dimensions
M 800
L 1400
I + U 300

Inlet Duct	Outlet Duct
Air flow (l/s)	P-value
4000	1.99
Velocity (m/s)	Pressure drop (Pa)
4.76	27

Frequency band (Hz)	63	125	250	500	1K	2K	4K	8K	Sum dB(A)
Lw before attenuator									
Attenuation	7	15	25	40	50	36	21	19	
Sound generation	24	24	20	18	15	12	11	9	21
Lw after attenuator	24	24	20	18	15	12	11	9	21

Add Silencer

Circular Rectangular

Straight Bend

Product: **LARGO**
Inlet / Outlet: **Duct** | **Duct**
M: 1400 mm
A: 600 mm
I + U: 300 mm
Baffle code: 1436

Enter sound level for each octave

	63	125	250	500	1000	2000	4000	8000	Hz	Sum
Lw before										7 dB(A)
Attenuation	7	15	25	40	50	36	21	19		dB
Noise generation	24	24	20	18	15	12	11	9		21 dB(A)
Lw after	24	24	20	18	15	12	11	9		21 dB(A)

Airflow: 4000 l/s | Face velocity: 4.76 m/s
Pressure drop: 27 Pa

Position: **LB01**

Notes: Supply

Buttons: Add, Update, Close

ProSilenzer

Hardcopy from ProSilenzer

Search Silencer

Product	Width	Height	Length	Pressure drop	Lw after	LS Hr	Q75 Hr	Q70 Hr	Q65 Hr	Q60 Hr	Q55 Hr	Q50 Hr	Q45 Hr
CA 130	1000	400	1050	4	6	6	11	20	30	20	13	12	
CA 130 - 1032 9000-400	1000	400	1050	4	6	6	11	20	30	20	13	12	
CA 130 - 1032 9000-400	1000	400	1050	11	9	8	15	25	44	40	29	21	18
CA 130 - 1032 9000-400	1000	400	1050	11	9	8	15	25	44	40	29	21	18
CA 130 - 1041 9000-400	1000	400	2450	25	18	12	24	33	58	50	42	32	
CA 130 - 1041 9000-400	1000	400	2450	5	5	7	14	25	36	37	23	15	13
CA 130 - 1043 9000-400	1000	400	2450	13	14	11	25	31	58	50	46	28	21
CA 130 - 1043 9000-400	1000	400	2450	13	14	11	25	31	58	50	46	28	21
FACE - 1015-9000-600	xxxx	xxxx	xxxx	xxxx	14	9	9	13	47	14	14	14	14

Airflow: 1800 l/s | Face velocity: 2.5 m/s | Pressure drop: 25 Pa

Position: Supply Air

Buttons: Back

MagiCAD logo

ProSilenzer in MagiCAD

Pressure drop

Common disturbance cases

Chamber connection

The chamber connection is a large change in dimension, for example, between a duct and room or manifold and duct, where the largest dimension is the chamber. This connection can give the sound attenuator a pressure drop that is up to 3 times higher than on a straight duct. The pressure drop can be calculated in ProSilencer or in the product sheet on www.swegon.com.

Sound attenuator installed by a branch

Sound attenuators installed by a branch can be compared with a chamber connection.

Sound attenuator installed by an elbow

When the sound attenuator is installed by an elbow, the pressure drop increases by about 1.5 times compared with installation on a straight duct. The calculation can be easily made in ProSilencer or in the product sheet on www.swegon.com

Sound attenuator installed by a damper

Sound attenuators installed by a damper can give an increased pressure drop. See the recommendations in each damper's documentation.

Sound attenuators installed in series

The spacing between each sound attenuator must be at least 4 x the duct diameter to avoid an increased pressure drop when installed in series.

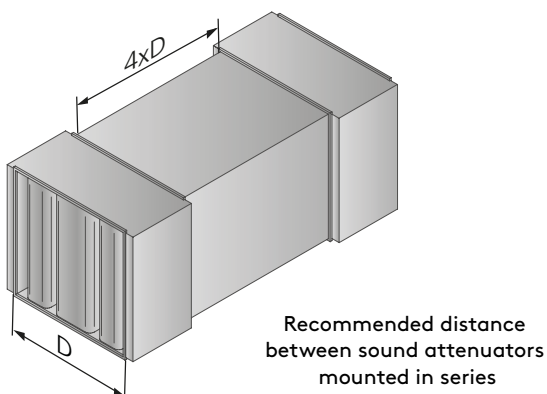

Good sound attenuation and low pressure drop

Good sound attenuation and a low pressure drop are usually inverse conditions as reduced free area gives improved sound attenuation, but at the same time a higher pressure drop.

Swegon has the solution!

With the help of pressure recovery and speed reduction, Swegon has lowered the pressure drop across the sound attenuator by approximately 15-20 %.

The upper illustration below shows a CALMO sound attenuator. The lower illustration shows a LARGO angled sound attenuator.

The baffles are designed according to the basic laws of aerodynamics. This together with the fact some of the sound attenuator's baffles have been placed outside of the connection means that the pressure drop has been reduced significantly towards conventional sound attenuators.

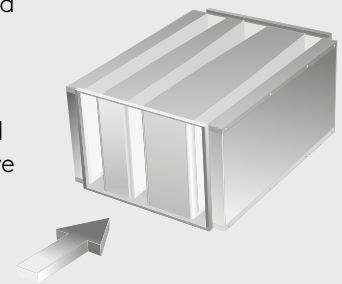

An angled sound attenuator with baffles designed as guide vanes for the air flow, can be replaced by a rectangular elbow (without guide vanes) with a maintained or even lower pressure drop.

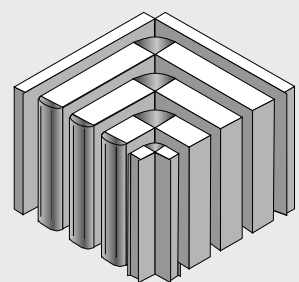

Rule of thumb

- If you use a sound attenuator to maintain a sound level in the duct after the fan of 55 dB(A) or NR50, you satisfy the majority of today's requirements in individual rooms.
- For duct-to-duct installation it is desirable that the pressure drop for the sound attenuator drops below 30 Pa and is max 50 Pa, to avoid high velocities that cause sound and pressure drop.
- As sound attenuators by the air handling unit can cause a high pressure drop, you should size for a pressure drop across the sound attenuator that can be about 3 times higher than for duct-to-duct installation.

CLA

A rectangular, compact sound attenuator with circular connection, that has very good sound attenuation and extremely low installation height.

CLA is perfectly suited to confined areas to reduce sound from dampers in the duct system as well as directly on the air handling unit with circular connection.

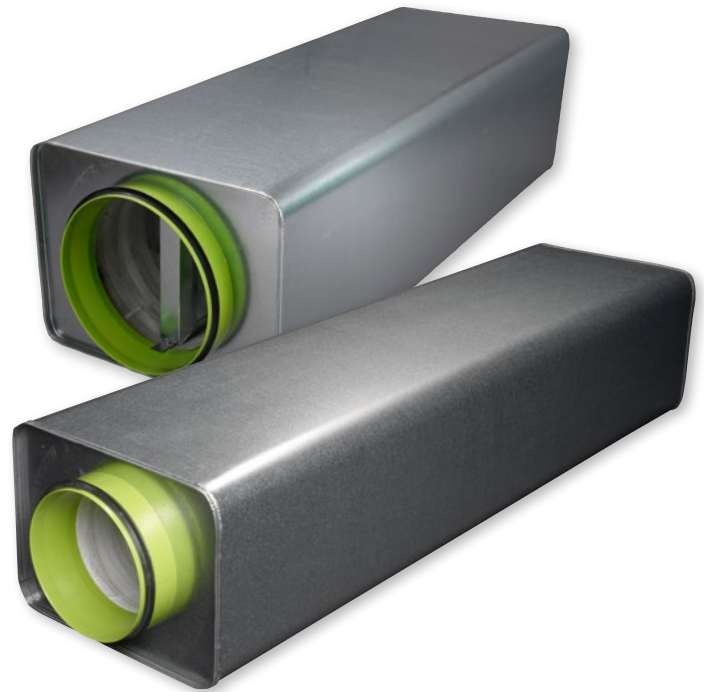

CLA-A with the following characteristics:

- Available in the sizes Ø 100-400
- Material: Galvanized sheet steel as standard.
- Insulation material: Mineral wool that is covered with special polyester fabric.
- Type approved fire resistance
- Air tightness class D
- Included in the MagiCad database

CLA-A: Standard range			
Dimensions mm	Length mm	Working range m³/s	Attenuation dB(A)
100-400	500-1000	0-2	5-25

CLA-B: Standard range			
Dimensions mm	Length mm	Working range m³/s	Attenuation dB(A)
250-800	500-1200	0-5	5-20

CLA-B with the following characteristics:

- Available in the sizes Ø 250-800
- Equipped with centre baffle
- Material: Galvanized sheet steel as standard.
- Included in the MagiCad database

CLA-B Ø 250-400:

- Insulation material: Mineral wool that is covered with special polyester fabric.
- Type approved fire resistance
- Air tightness class D

CLA-B Ø 500-800:

- Insulation material: ISOVER Cleantec® PLUS, is a type approved insulation material consisting of long-fibred compressed mineral wool covered with a micro-perforated aluminium foil. The insulation material is type approved in terms of cleaning using liquids with a plastic brush or even a high-pressure cleaner.
- Air tightness class C

SORDO-A, SORDO-C

SORDO is a circular sound attenuator with circular connection that is available in several designs and sizes with fire-resistance class.

All variants are perfectly suited to reduce sound from dampers in the duct system as well as directly on the air handling unit with circular connection.



SORDO-A with the following characteristics:

- 50 mm thick rock wool
- Available in the sizes Ø 100-400
- Material: Galvanized sheet steel as standard.
- Insulation material: Mineral wool that is covered with special polyester fabric
- Type approved fire resistance
- Air tightness class D
- Included in the MagiCad database

SORDO-A: Standard range			
Dimensions mm	Length mm	Working range m ³ /s	Attenuation dB(A)
100-400	500-1100	0-2	5-20

SORDO-C: Standard range			
Dimensions mm	Length mm	Working range m ³ /s	Attenuation dB(A)
100-400	500-1100	0-2	5-25

SORDO-C with the following characteristics:

- 100 mm mineral wool
- Available in the sizes Ø 100-400
- Material: Galvanized sheet steel as standard.
- Insulation material: Mineral wool that is covered with special polyester fabric
- Air tightness class D
- Included in the MagiCad database

SORDO-B, SORDO-P/-PF

A circular sound attenuator with circular connection that is available in several different designs and sizes with fire-resistance class.

All variants are perfectly suited to reduce sound from dampers in the duct system as well as directly on the air handling unit with circular connection.



SORDO-B with the following characteristics:

- 100 mm mineral wool
- Available in the sizes Ø 315-800
- Equipped with centre baffle
- Material: Galvanized sheet steel as standard.
- Insulation material: Long fibre compressed mineral wool. The mineral wool is covered with polyester fabric. On size 500-800 the polyester fabric is also covered with perforated sheet steel
- SORDO-B Ø 315-400 has leakage class D
- SORDO-B Ø 500-800 has leakage class C
- Included in the MagiCad database

SORDO-P with the following characteristics:

- 100 mm thick rock wool
- Available in the sizes Ø 500-2000
- Equipped with an aerodynamically designed centre body (pod) for optimal acoustic and pressure-drop characteristics
- Material: Galvanized sheet steel as standard.
- The insulation is covered with polyester fabric which is also covered with perforated sheet steel
- Included in the MagiCad database

SORDO-B: Standard range			
Dimensions mm	Length mm	Working range m ³ /s	Attenuation dB(A)
315-800	500-1200	0-5	10-20

SORDO-P/-PF: Standard range			
Dimensions mm	Length mm	Working range m ³ /s	Attenuation dB(A)
500-2000	900-4000	0-30	5-15

SORDO-PF with the following characteristics:

- Same characteristics as SORDO-P except it has flange connections instead of connection spigots.

CALMO

A space-saving, rectangular sound attenuator with recessed connection, that has excellent aerodynamic properties and good sound attenuation and very low pressure drop.

These characteristics make CALMO suitable for use both in ducts and in direct connection to the ventilation unit.



CALMO with the following characteristics:

- Available in the connection dimensions from 400x300 mm to 2200x2200 mm
- Material: Supplied as standard in galvanised sheet steel
- Insulation material: Type approved sound attenuating material, ISOVER Cleantec® PLUS which is also wet-cleanable.
- Can be supplied in kit form, which makes it possible to insert in large sound attenuators through confined passages for example, during renovation work. Final installation on site by the customer with the help of the accompanying instructions
- Available with numerous optional accessories
- Supplied as standard with joint profiles for guide connection
- Possibility of special adaptations such as other sizes, air handling unit adaptation and other material options for example, stainless steel, alu-zinc, etc
- Included in the MagiCad database

CALMO - Standard range				
Measurement			Working range	Attenuation
B mm	H mm	L mm		
400-2200	300-2200	650-2450	0-40 m ³ /s	10-35 dB(A)

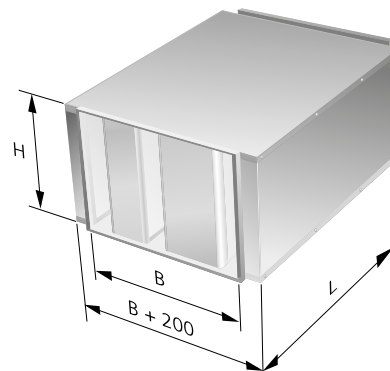

Accessories

Selectable accessories for CALMO

- CALMO T1 = Uninsulated cleaning hatch
- CALMO T2 = Fire resistant insulated cleaning hatch
- CALMO T3 = Sound attenuator fire resistant insulated with 50 mm thick mineral wool
- CALMO T4 = Perforated metal covering

Read more about CALMO and all accessories at www.swegon.com.

CADENZA

A rectangular sound attenuator with connection to the outer casing, designed to meet today's high demands on sound attenuation and pressure drop.

CADENZA is especially suitable for use out in the duct system, but can also be used in direct connection to the ventilation unit.



CADENZA with the following characteristics:

- Available in the connection dimensions from 400x300 mm to 2200x2200 mm
- Material: Supplied as standard in galvanised sheet steel
- Insulation material: Type approved sound attenuating material, ISOVER Cleantec® PLUS which is also wet-cleanable.
- Available with numerous optional accessories
- Supplied as standard with joint profiles for guide connection
- Possibility of special adaptations such as other sizes, air handling unit adaptation and other material options for example, stainless steel, alu-zinc, etc
- Can be supplied in kit form, which makes it possible to insert in large sound attenuators through confined passages for example, during renovation work. Final installation on site by the customer with the help of the accompanying instructions
- Included in the MagiCAD database

CADENZA: Standard range				
Measurement			Working range	Attenuation
B	H	L		
mm	mm	mm	m ³ /s	dB(A)
400-2200	300-2200	650-2450	0-33	10-30

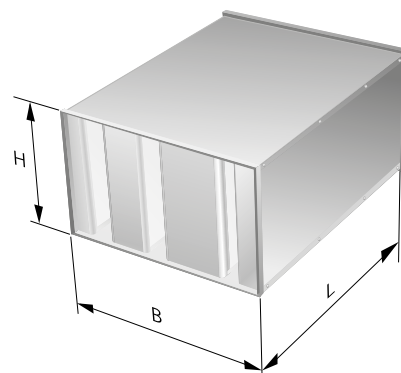

Accessories

Selectable accessories for CADENZA

- CADENZA T1 = Uninsulated cleaning hatch
- CADENZA T2 = Fire resistant insulated cleaning hatch
- CADENZA T3 = Sound attenuator fire resistant insulated with 50 mm thick mineral wool
- CADENZA T4 = Perforated metal covering.
- CADENZA T5 = Flange connection

Read more about CADENZA and all accessories at www.swegon.com.

LARGO

An angled sound attenuator with recessed connection and aerodynamically shaped baffle elements with good sound attenuation and low pressure drop.

With these characteristics LARGO is suitable for use both in ducts and in direct connection to the ventilation unit.



LARGO with the following characteristics:

- Very space saving rectangular sound attenuator
- Excellent aerodynamic characteristics
- Very low pressure drop - baffles serve as guide vanes
- Material: Supplied as standard in galvanised sheet steel
- Insulation material: Type approved sound attenuating material, ISOVER Cleantec® PLUS which is also wet-cleanable.
- Available with numerous optional accessories
- Can be supplied in kit form, which makes it possible to insert in large sound attenuators through confined passages for example, during renovation work. Final installation on site by the customer with the help of the accompanying instructions
- Connection dimensions from 400x300 mm to 2000x2000 mm
- Possibility of special adaptations such as other sizes, air handling unit adaptation and other material options for example, stainless steel, alu-zinc, etc.
- Supplied as standard with joint profiles for guide connection
- Included in the MagiCAD database

LARGO - Standard range				
Measurement			Working range	Attenuation
M	A	I+U		
mm	mm	mm	m ³ /s	dB(A)
400-2000	300-2000	300-900	0-17	20-40

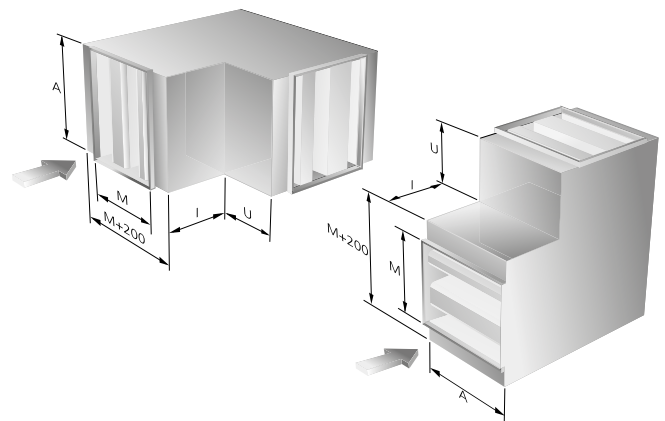

Accessories

- LARGO T1 = Uninsulated cleaning hatch*
- LARGO T2 = Fire resistant insulated cleaning hatch*
- LARGO T3 = Sound attenuator fire resistant insulated with 50 mm thick mineral wool
- LARGO T4 = Perforated metal covering

* For placement of cleaning hatch, see the accessories section

Read more about LARGO and all accessories at www.swegon.com.

LENTO

An angled sound attenuator with connection to the outer casing and equipped with baffles that serve as guide vanes to deflect the air flow.

LENTO is suitable for use both in ducts and in direct connection to the ventilation unit.



LENTO with the following characteristics:

- Very space saving rectangular sound attenuator
- Excellent aerodynamic characteristics
- Very low pressure drop - baffles serve as guide vanes
- Material: Supplied as standard in galvanised sheet steel
- Insulation material: Type approved sound attenuating material, ISOVER Cleantec® PLUS which is also wet-cleanable.
- Available with numerous optional accessories
- Connection dimensions from 400x300 mm to 2000x2000 mm
- Can be supplied in kit form, which makes it possible to insert in large sound attenuators through confined passages for example, during renovation work. Final installation on site by the customer with the help of the accompanying instructions.
- Possibility of special adaptations such as other sizes, air handling unit adaptation and other material options for example, stainless steel, alu-zinc, etc.
- Supplied as standard with joint profiles for guide connection
- Included in the MagiCAD database

LENTO - Standard range				
Measurement			Working range	Attenuation
M	A	I+U		
mm	mm	mm	m ³ /s	dB(A)
400-2000	300-2000	300-900	0-17	20-40

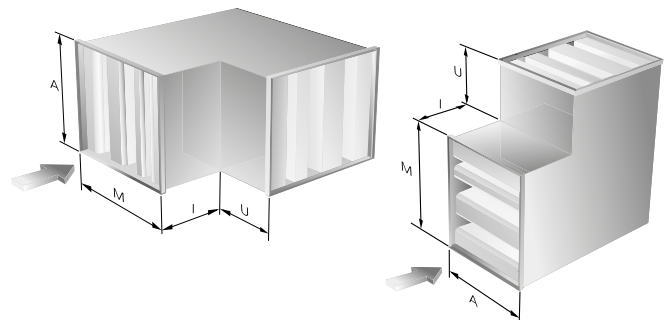

Accessories

- LENTO T1 = Uninsulated cleaning hatch*
- LENTO T2 = Fire resistant insulated cleaning hatch*
- LENTO T3 = Sound attenuator fire resistant insulated with 50 mm thick mineral wool
- LENTO T4 = Perforated metal covering
- LENTO T5 = Flange connection

* For placement of cleaning hatch, see the accessories section.

Read more about LENTO and all accessories at www.swegon.com.

FACILE

A hygienic sound attenuator with extractable baffles, used where extra high demands are made on cleanability.

FACILE with its good aerodynamic characteristics and low pressure drop is suitable for use both in ducts and in direct connection to the ventilation unit.



FACILE with the following characteristics:

- Rectangular sound attenuator with extractable baffles
- Used where extra high demands are made on hygiene requirements and easy access for cleaning
- Material: Supplied as standard in galvanised sheet steel
- Insulation material: Type approved sound attenuating material, ISOVER Cleantec® PLUS which is also wet-cleanable.
- Low pressure drop via baffle staging
- Connection dimensions from 400x300 mm to 2200x2200 mm
- Available with numerous optional accessories
- Possibility of special adaptations such as other sizes, air handling unit adaptation and other material options for example, stainless steel, alu-zinc, etc
- Supplied as standard with joint profiles for guide connection
- Included in the MagiCAD database

FACILE - Standard range				
Measurement			Working range	Attenuation
B	H	L		
mm	mm	mm	m ³ /s	dB(A)
400-2200	300-2200	750-1950	0-34	10-25

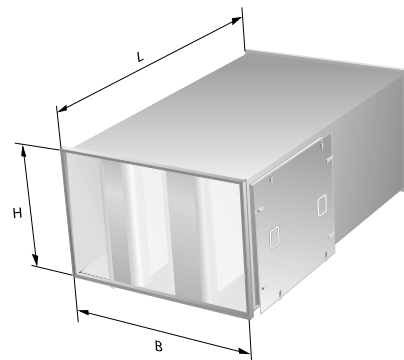

Accessories

- FACILE T2 = Fire resistant insulated cleaning hatch
- FACILE T4 = Perforated metal covering
- FACILE T5 = Flange connection

Read more about FACILE and all accessories at www.swegon.com.

MORENDO

A rectangular sound attenuator with extra low installation height for use in installations where space is very limited.

MORENDO is perfectly suited to reduce sound from dampers in the duct system as well as to be installed directly by the ventilation unit.



MORENDO with the following characteristics:

- Can be used wherever rectangular sound attenuators are used
- Compact design
- Low pressure drop via baffle staging
- Material: Supplied as standard in galvanised sheet steel
- Insulation material: Type approved sound attenuating material, ISOVER Cleantec® PLUS which is also wet-cleanable.
- Available with numerous optional accessories
- Possibility of special adaptations such as other sizes, air handling unit adaptation and other material options for example, stainless steel, alu-zinc, etc
- Connection dimensions from 150x150 to 1000x400 mm
- Supplied as standard with joint profiles for guide connection
- Included in the MagiCAD database

MORENDO - Standard range				
Measurement			Working range	Attenuation
B	H	L		
mm	mm	mm	m ³ /s	dB(A)
150-1000	150-400	650-1250	0-2	15-20

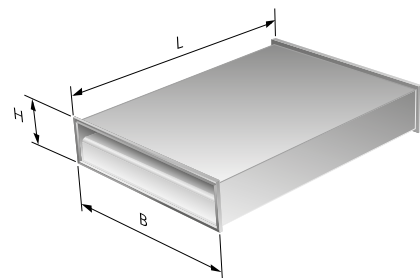

Accessories

- MORENDO T1 = Uninsulated cleaning hatch
- MORENDO T2 = Fire resistant insulated cleaning hatch 50 mm mineral wool
- MORENDO T3 = Fire resistant insulated 50 mm mineral wool
- MORENDO T4 = Perforated metal covering
- MORENDO T5 = Flange connection

Read more about MORENDO and all accessories at www.swegon.com.

ALD

A sound attenuating exterior wall grille that efficiently reduces noise from fans and machine rooms, etc. The sound is attenuated on passing the sound absorbing fins.

ALD is primarily used as an intake/or exhaust grille in ventilation systems, but can also be used as e.g. a venting grille in compressor rooms.



ALD with the following characteristics:

- Excellent noise attenuation
- A robust grille that withstands difficult climate conditions
- Material: Supplied as standard in galvanised sheet steel or aluminium
- Possibility of special adaptations with other material options for example, stainless steel, alu-zinc or painted finish
- Also available in double design for extra sound attenuation

ALD: Standard range				
Measurement			Working range	Attenuation
B	H	D		
mm	mm	mm	m ³ /s	dB(A)
300-2500	450-2400	300-600	0-15	12-18

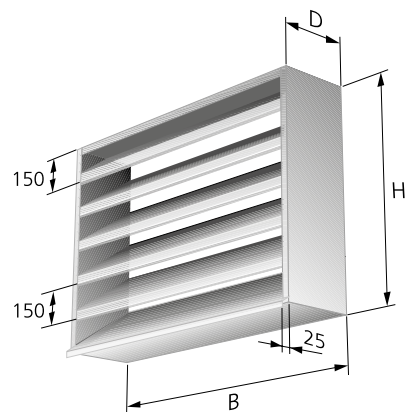

Accessories

- ALDT1 = Wire net
 ALDT2 = Mounting frame

Read more about ALD and accessories at www.swegon.com.

CTM/CTK

Sound-attenuating transfer diffuser for large air flow, which with the help of a labyrinth of mineral wool and angle changes efficiently attenuates the sound, at the same time as the pressure drop is kept low.

CTK and CTM are suitable as air transfer diffusers in large premises such as conference rooms.



CTK and CTM with the following characteristics:

- For transfer air over the wall or through wall/ceiling
- Large flow area up to 220 l/s
- Insulation material: Type approved sound attenuating material, ISOVER Cleantec® PLUS which is also wet-cleanable.
- Simple to install

Accessories

For CTK and CTM a grille is normally needed for each opening. GRL with FHB mounting frame is recommended if a grille for low pressure drop is required.

GRL = Grille in extruded aluminium profiles, finished in white standard colour

FHB = Mounting frame for GRL grilles made of galvanised sheet steel

Read more about CTM and CTK at www.swegon.com

If you are looking for air transfer diffusers for smaller air flows we recommend Swegon's sound attenuating transfer diffusers CIRCO, ORTO and SOTTO.

See the product section for diffusers at www.swegon.com

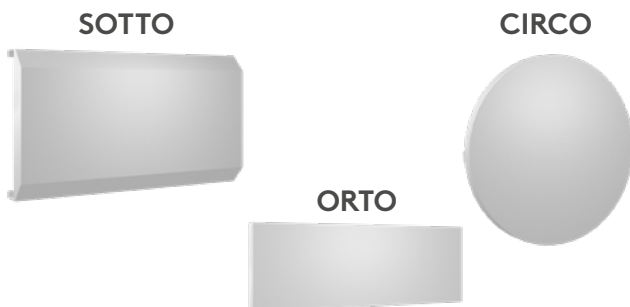

Working range
 SOTTO: 0-30 l/s
 CIRCO: 0-50 l/s
 ORTO: 0-100 l/s

CTK: Standard range						
Measurement					Working range	Rw
A	B	C	H	L		
mm	mm	mm	mm	mm	l/s	(dB)
150-300	250-600	50-150	250	1000	0-220	36-40

CTM: Standard range					
Measurement				Working range	Rw
A	B	H	L		
mm	mm	mm	mm	l/s	(dB)
150-200	300-800	225-250	750-900	0-200	29-32

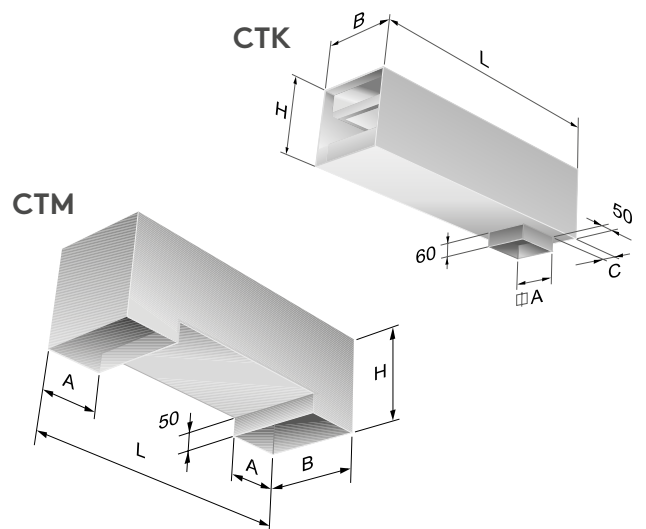

Accessories

FACILE with flange connection

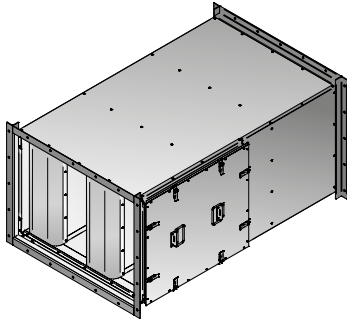

CALMO with cleaning hatch

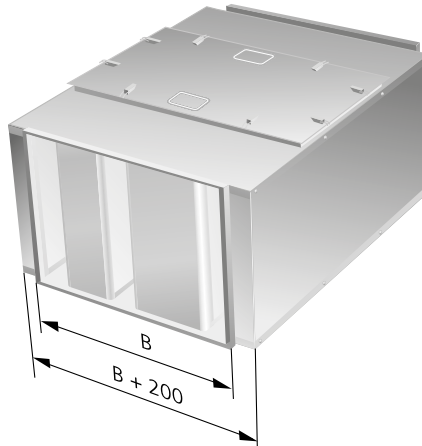

CADENZA with fire insulation

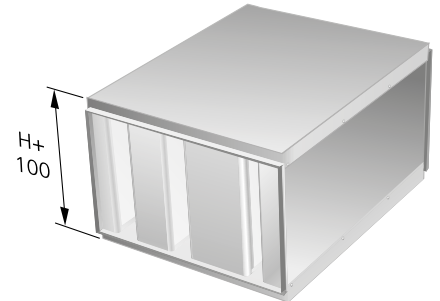

Placement of the cleaning hatch LARGO, LENTO

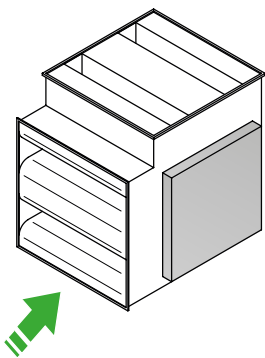

T1-1 Vertical right

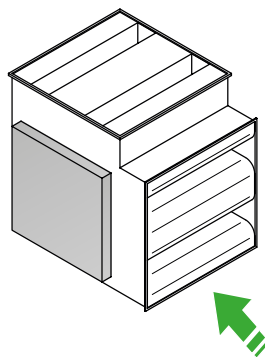

T1-2 Vertical left

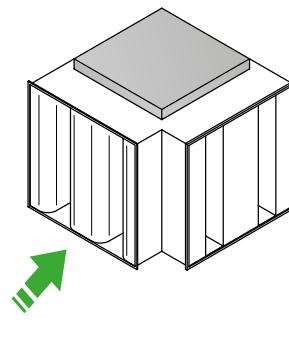

T1-3 Horizontal above

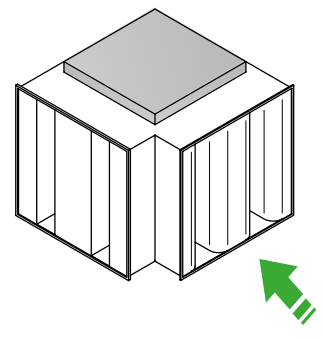

T1-4 Horizontal below

Fire-resistance classes

The fire resistance of building elements and structures can be classified in different fire-resistance classes or combinations of these. The different classes specify different types of functional requirements. Normally the class designation also includes a number, which indicates how long the functional requirements are met during standardised testing.

An example of classification is EI 30, which means that the structure is fireproof (E) and insulating (I) for 30 minutes.

E. Integrity (density)

Integrity E is the ability of a building element, with a separating function, to withstand fire on one side without the fire spreading to the unexposed side through leakage of flames or hot gases. For the assessment of the element's integrity the following parameters are relevant:

- cracks or openings over a specific size
- ignition of a wad of cotton wool
- prolonged flames on the unexposed side of the fire

I. Insulation

Insulation I is the ability of a building element, in the event of a fire on one side, to maintain the temperature on the unexposed side below a specific level. Generally, the maximum temperature rise in any single point, which must not exceed 180 K, and a mean temperature rise at certain points, which must not exceed 140 K are taken into consideration.

Source: RISE Research Institutes of Sweden

Complete supply and extract air kits

Complete supply/extract air kits are available to order with a number of different products, for example, the PARAGON and PARASOL families. Swegon's supply/extract air kits are available both as VAV- and CAV-kits



The illustration shows a hotel room where the supply and extract air kits are order together with PARAGON for easy and effortless installation

The supply air kit consists of a sound attenuator and a damper.

- Sound attenuator CLA-A in length 500 mm.
- Damper to CAV-kit CRPc-9 Commissioning damper with manually adjustable perforated blade.
- Damper to VAV-kit CRTc motor driven damper incl. Swegon motor.

The extract air kit consists of a sound attenuator, a damper and an extract air valve complete with mounting frames, nipple and union.

- Sound attenuator CLA-A in length 500 mm.
- Extract air register EXCa complete with mounting frames, nipple and union
- Damper to CAV-kit CRPc-9 Commissioning damper with manually adjustable perforated blade
- Damper to VAV-kit CRTc motor driven damper incl. Swegon motor.

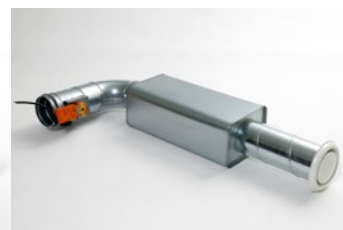
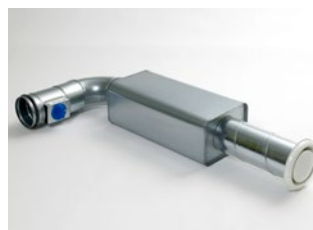
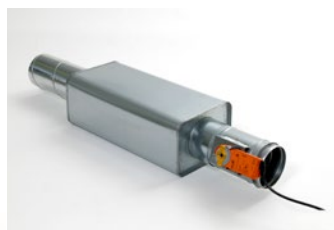
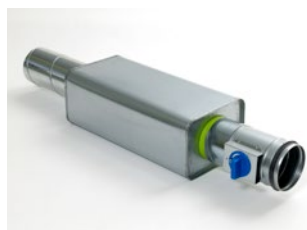

Selection guide

Duct products with circular connection

Product	Dimensions mm		Working range m ³ /s	Attenuation dB(A)	Fire-resistance class			Special characteristics
	Ø	L-measurement			EI30	EI60	EI120	
CLA-A	100 - 400	500 - 1000	0-2	5-25	•	•	•	Low installation height
CLA-B	250 - 400	500 - 1000	0-0.8	10-20	•	•	•	Low installation height, centre baffle
CLA-B	500 - 800	600 - 1200	0-5	5-15	-	-	-	
SORDO-A	100 - 400	500 - 1100	0-2	5-20	•	•	•	Compact
SORDO-B	315 - 400	500 - 1100	0-2	15-20	-	-	-	Centre baffle
SORDO-B	500 - 800	900 - 1200	0-5	10-20	-	-	-	Centre baffle
SORDO-C	100 - 400	500 - 1100	0-2	5-25	-	-	-	More insulation
SORDO-P	500 - 2000	900 - 4000	0-30	5-15	-	-	-	Centre pod
SORDO-PF	500 - 2000	900 - 4000	0-30	5-15	-	-	-	Flange connection, centre pod

• = May require safety distance

Duct products with rectangular connection

Product	Dimensions mm measurement			Working range m ³ /s	Attenuation dB(A)	Fire-resistance class			Special characteristics
	B	H	L			EI30	EI60	EI120	
CALMO	400-2200	300-2200	650-2450	0-40	10-35	-	-	-	Recessed connection
CADENZA	400-2200	300-2200	650-2450	0-33	10-30	-	-	-	Flange connection as an option
FACILE	400-2200	300-2200	750-1950	0-34	10-25	-	-	-	Simple to clean
MORENDO	150-1000	150-400	650-1250	0-2	15-20	-	-	-	Compact

Duct products with rectangular connection

Product	Dimensions mm measurement			Working range m ³ /s	Attenuation dB(A)	Fire-resistance class			Special characteristics
	M	A	I+U			EI30	EI60	EI120	
LARGO	400-2000*	300-2000	300-900	0-17	20-40	-	-	-	Angled attenuator, recessed connection
LENTO	400-2000*	300-2000	300-900	0-17	20-40	-	-	-	Angled attenuator

* The width of the duct for horizontal installation: Duct height for vertical installation

Exterior wall grille

Product	Dimensions mm measurement			Working range m ³ /s	Attenuation dB(A)	Fire-resistance class			Special characteristics
	B	H	D			EI30	EI60	EI120	
ALD	300-2500	450-2400	300-600	0-15	12-18	-	-	-	Exterior wall grille

Air transfer diffuser

Product	Dimensions mm measurement				Working range m ³ /s	Attenuation Rw (dB)	Fire-resistance class			Special characteristics
	A	B	H	L			EI30	EI60	EI120	
CTM	150-200	300-800	225-250	750-900	0-200	29-32	-	-	-	Air transfer diffuser, C-measurement 50-150
CTK	150-300	250-600	250	1000	0-220	36-40	-	-	-	Air transfer diffuser

Feel good **inside**

