

Technical description

General

The U4X hybrid system is a multifunctional radiant ceiling system and is ideal for meeting the increasing demands of modern buildings. A special feature of the U4X is inclusion of the building mass through direct control of the concrete ceiling. This results in a mass storage capacity in addition to the usual water and air cooling capacity. This can significantly reduce operating costs and CO₂ emissions.



The U4X hybrid ceiling module is particularly suitable for offices, conference rooms, hotels, schools and other commercial applications. It not only ensures comfort, but also promotes productivity and the wellbeing of employees and customers.

Activation

Water system: The radiant ceiling is a passive system that in the case of cooling absorbs heat from the room via the ceiling surface, transfers it to the water, which is conducted in activation registers, and dissipates it, respectively emits heat in the case of heating.

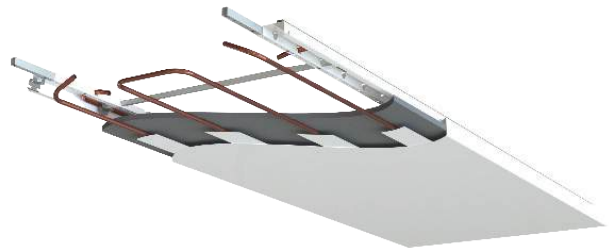

The activation of the U4X consists of meandering copper pipes (outside diameter 12 mm) and aluminum heat-conducting rails (width 80 mm), which are connected by laser spot welding and glued into the ceiling panels.

Functions

The U4X hybrid ceiling module is multifunctional. In addition to the thermal functions of cooling/heating, there is the possibility of further integration: various built-in components (e.g. smoke detectors, lighting).

Functional description of the U4X

The special design of the U4X module, consisting of ceiling panel and frame, makes it possible to utilise the advantages of a radiant ceiling module, whilst also incorporating the building mass as an energy store. Thanks to the thermally active frame, the concrete ceiling directly above can be actively managed and the building mass utilised as an energy store. This allows load peaks to be shifted.

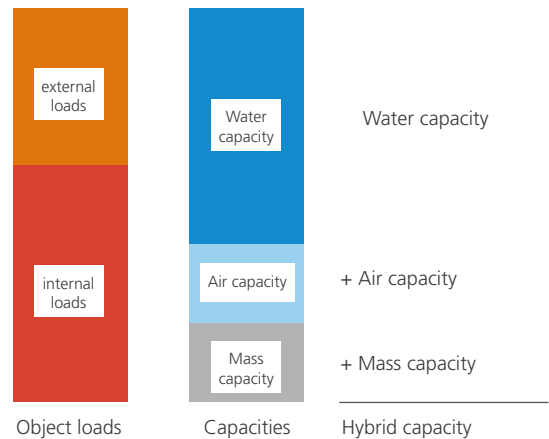

Technical data

Capacity

Initial data is presented below.

Material ceiling panel	Aluminum	Steel
Perforation	Rg 1,5 – 11 %	Rg 1,5 – 11 %
Distance heat conducting rails (hcr)	100 mm --- ② 150 mm — ③	100 mm ① 150 mm — ④
Activation method	on fleece	on fleece

(Capacity information without project-specific performance-influencing factors.)

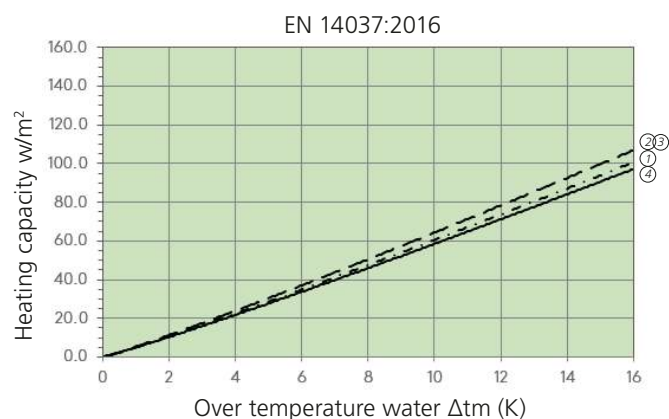
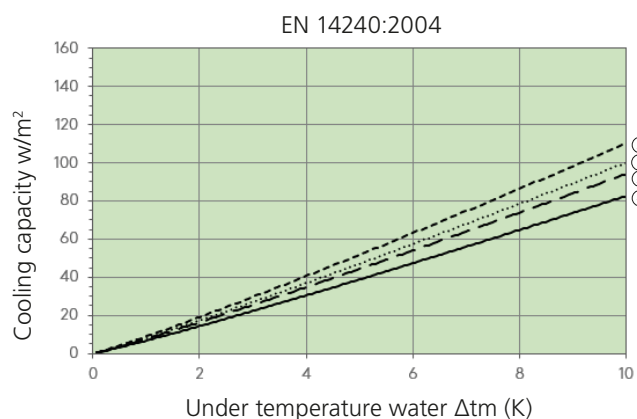

Version	Cooling 8 K	Cooling 10 K	Heating 15 K
① Steel 100 mm	up to 79 W/m ²	up to 100 W/m ²	up to 94 W/m ² (.....)
② Aluminum 100 mm	up to 87 W/m ²	up to 110 W/m ²	up to 103 W/m ² (-----)
③ Aluminum 150 mm	up to 74 W/m ²	up to 94 W/m ²	up to 100 W/m ² (-----)
④ Steel 150 mm	up to 65 W/m ²	up to 83 W/m ²	up to 91 W/m ² (———)

Notice

- SN EN 14240: The cooling capacity is related to the active area according to SN EN 14240:2004. The active area is calculated according to SN EN 14240 from the number of heat-conducting rails x length of heat conducting rail x distance between heat conducting rails.
- SN EN 14037: The heating capacity is related to the active area according to SN EN 14037:2016. The active area is calculated according to SN EN 14037 from the length of the ceiling panel x the width of the ceiling panel.

Recommendations for operation

Water



- Temperature
 - Cooling 16 – 18 °C
 - Heating 28 – 37 °C
- Temperature distance Δt (VL-RL): 2 – 3 K
- Pressure drop: 20 – 25 kPa
- Water flow: 80 – 150 l/h
- Max. operating pressure up to 9 bar
- Water quality according to: SWKI BT 102-01, BTGA 3.003, VDI 2035

Surrounding

- Ambient temperatures: +5 – 50 °C
- Humidity: up to 90 % relative humidity

Acoustics

Initial data is presented below.

Perforation	Rd 1,5 – 22 %	Rg 1,5 – 11 %	Rg 1,5 – 11 %
Acoustic inlay	with 	with 	with 
Additional inlay	Soundabsorber	Mineral wool in PE	Mineral wool in PE + additive
Sound absorption α_p	250: 0,70 500: 1,00 1k: 1,00 2k: 0,95 4k: 0,70	250: 0,75 500: 1,00 1k: 0,95 2k: 0,75 4k: 0,65	250: 0,95 500: 0,95 1k: 0,90 2k: 0,75 4k: 0,65
Sound absorption α_w	α_w : 0,90	α_w : 0,80	α_w : 0,80 (L)
Sound absorption class (EN ISO 11654)	A	B	B

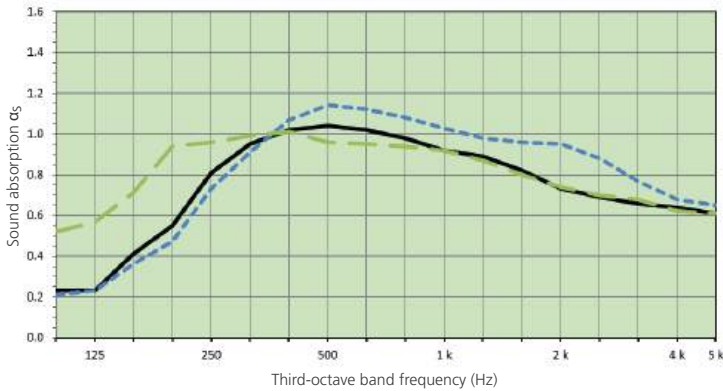

Air connection box

Standard sound level difference (Telephony sound attenuation)

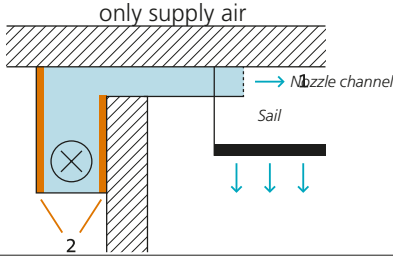
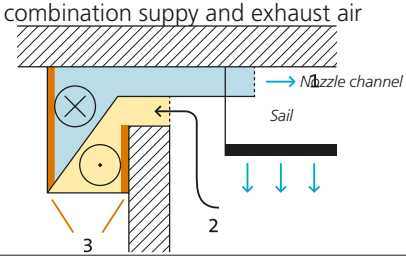
Versions		
without internal attenuation	$D_{n,e,w} = 58 \text{ dB}$	$D_{n,e,w} = 50 \text{ dB}$
with internal attenuation	$D_{n,e,w} = 62 \text{ dB}$	$D_{n,e,w} = 55 \text{ dB}$

Sound power level L_{WA}

Supply air volume	q_v	m^3/h	76	90	104	118	136
	$q_v/lm \text{ channel}$	m^3/lm^*h	25	30	35	40	45
Sound power level	L_{WA}	dB	24,1	27,3	31,0	34,7	38,2

System

Ceiling system

- Ceiling module with building mass connection
 - Rectangular panels
 - Frame

Installation systems

- Installation high: 75 mm
 - Frame construction for mounting on the concrete ceiling

Materials, weight and dimensions

Materials and weight

Material	Weight (incl. activation, water)
Steel 0,70 mm	approx. 12,5 kg/m ²

Building material class: A2-s1, d0, EN 13501-1 (depending on the acoustic solution).

Dimensions

Length	Width	Height
min. 800 mm	min. 400 mm	min. 50 mm
max. 3000 mm	max. 1200 mm	max. 100 mm

Special dimensions on request.

Surface

Versions

- Powder coating
- Digital printing on request

Colors

- Standard RAL 9010
- Other RAL / NCS colors on request

Perforations

- Standard perforations
- Other perforations on request

Standard-Perforationen:

Rd 1,5 – 11 %

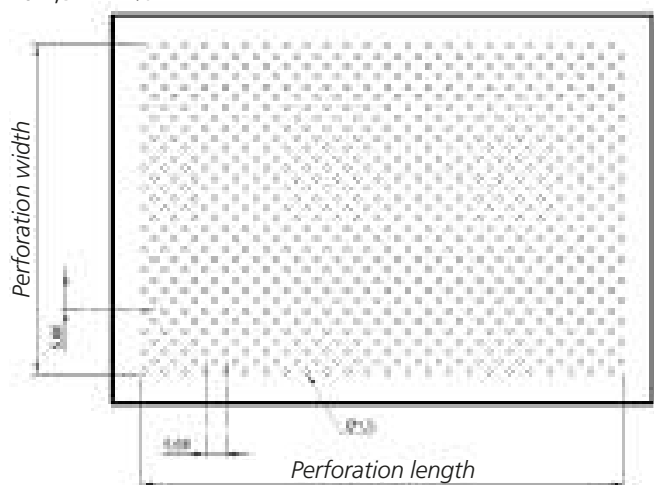

Rg 1,5 – 11 %

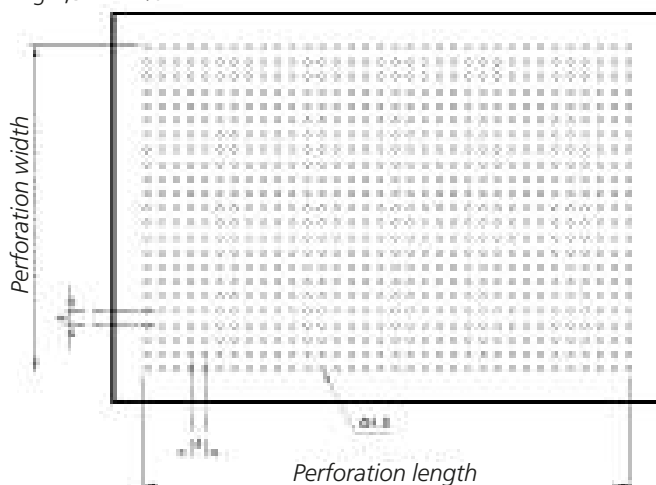

Rd 1,5 – 22 %

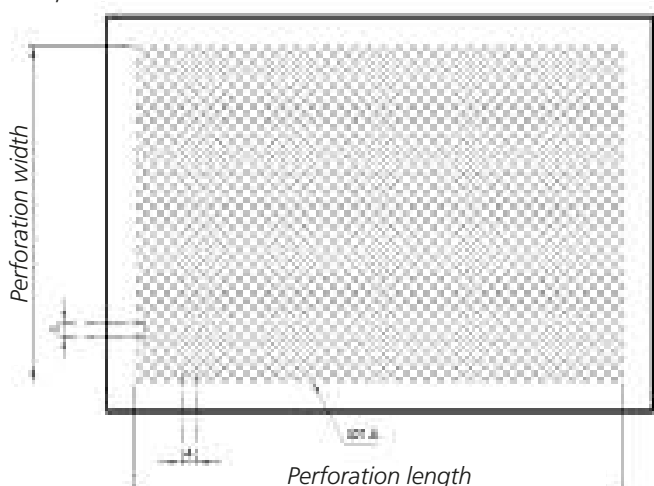

International

Barcol-Air Group AG

Wiesenstrasse 5
8603 Schwerzenbach
T +41 58 219 40 00
F +41 58 218 40 01
info@barcolair.com

Switzerland



Barcol-Air AG

Wiesenstrasse 5
8603 Schwerzenbach
T +41 58 219 40 00
F +41 58 218 40 01
info@barcolair.com

Barcol-Air AG

Via Bagutti 14
6900 Lugano
T +41 58 219 45 00
F +41 58 219 45 01
ticino@barcolair.com

Germany

Swegon Klimadecken GmbH

Schwarzwaldstrasse 2
64646 Heppenheim
T: +49 6252 7907-0
F: +49 6252 7907-31
vertrieb.klimadecken@swegon.de
swegon.de/klimadeckensysteme

France

Barcol-Air France SAS

Parc Saint Christophe
10, avenue de l'Entreprise
95861 Cergy-Pontoise Cedex
T +33 134 24 35 26
F +33 134 24 35 21
france@barcolair.com

Italy

Barcol-Air Italia S.r.l.

Via Leone XIII n. 14
20145 Milano
T +41 58 219 45 40
F +41 58 219 45 01
italia@barcolair.com