

FAVO

Hybrid system with building mass connection



QUICK FACTS

- In combination with A11-S, SPECTRA M-S
- Very high heating & cooling capacity
- Superior sound absorption values (class A)
- Enhanced energy efficiency thanks to active building mass connection
- Sound power level L_w : < 30 dB (A)
- Fresh air intake is silent and draught-free
- Connection to conventional ventilation ducts



Technical description

General

Thanks to its comprehensive functionality, the hybrid system FAVO plus the A11-S or SPECTRA M-S heating & cooling sails achieves an optimum room climate in any environment. It has very high cooling and heating capacities, a comfortable air supply and superior acoustic properties. According to the principle of the thermoactive component system, it also includes the storage mass for the dissipation of heat loads in the overall room thermal concept. This reduces energy requirements and operating costs.

Activation

Water system: The radiant ceiling is a passive system that in the case of cooling absorbs heat from the room via the ceiling surface, transfers it to the water, which is conducted in activation registers, and dissipates it, respectively emits heat in the case of heating.

Two variants of activation registers are available for activating the radiant metal ceiling system:

Activation register A11-S

- Copper pipe meanders welded to aluminum heat-conducting rails.
- Connected to the ceiling panel using adhesive technology.

Activation register SPECTRA M-S

- Copper pipe meanders pressed into aluminum heat-conducting profile with magnetic tape.
- Connected to the ceiling panel using magnet technology. Advantages: The registers can be supplied, fixed and hydraulically connected independently of the ceiling panels. These can be assembled at the end of the installation work. This reduces construction time and the risk of contamination.

Optional performance plus: Convector Wings

When using the activation register A11, a further increase in performance can be achieved by using the Convector Wings developed by Barcol-Air.

Convector Wings are matt black anodized aluminum profiles with slotted «wings» on both sides. With the profile that opens downwards, the Convector Wings can be attached to the straight sections of a pipe meander. This multiplies the heat exchange surface of the radiant ceiling sail, which leads to an increase in water capacity.

Functions

In addition to the thermal functions of cooling/heating and the active concrete management, there is the possibility of further integration: acoustically effective inserts or baffles (ARCHISONIC®), various built-in components (e.g. smoke detectors, lighting).

Combination

- FAVO + A11-S + ARCHISONIC®
- FAVO + SPECTRA M-S

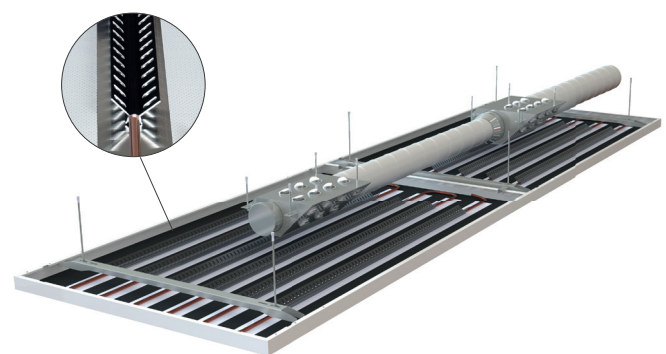

Optional performance plus: Convector Wings

Functional description

Specially developed high-performance induction nozzles deliver up to 120 m³/h of fresh air per FAVO. The escaping air creates negative pressure behind the diffuser, which induces warm room air onto the upper side of the ceiling sail. The patented wing shape of the supply air diffuser reduces the speed of this recirculating air above the wing, ensuring a high energy transfer into the building mass of more than 10 W/m². The accelerated flow under the wing removes the cold air pool from the ceiling panel. This increases the energy transfer to the water by 15 % compared to conventional ceiling sails.

The fan-shaped air flow creates a draught-free, complete mixing of the room air with a homogeneous temperature profile in the occupied area.

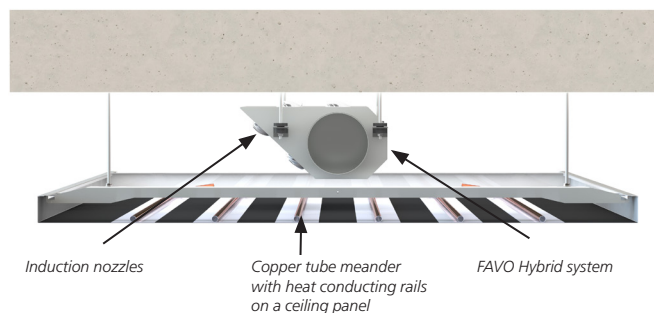

Building mass connection

The concrete ceiling is the most solid component of a room. Due to its high heat capacity, it can store a lot of energy. The FAVO supply air diffuser provides additional building mass connection, which means that less cooling is required during the day when electricity is expensive and the COP of the cooling system is low due to the outside temperature.

Day

In addition to the portion of energy directly transferred to the water, warm air also flows above the FAVO supply air outlet along the concrete, heating it in the process. This energy does not need to be dissipated during the day but is temporarily stored until the night.

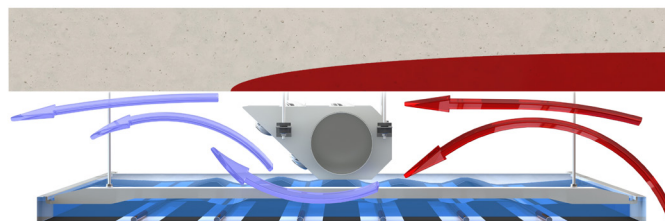

Night

At night, no supply air is required in the building. The water can be cooled by free cooling (without the use of the refrigerator). Through the exchange of radiation between warm concrete and cold heat conducting rails, the energy is extracted from the concrete and prepared for the absorption of excess energy the next day.

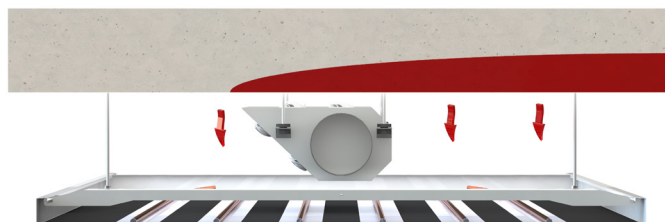

Technical data

Capacity

Water

Initial data is presented below.

Material ceiling panel	Aluminium	Steel
Perforation	Rg 1,5 – 11 %	Rg 1,5 – 11 %
Activation (Distance heat conducting rails hcr: 100 mm)	A11-----②	A11 + Convector Wings.....① A11——③ Spectra M- - -④
Activation method	on fleece	on fleece

(Capacity specifications without object-specific performance-increasing factors. Depending on the configuration, an additional output of 20 w/m² of panel area is achieved through concrete management.)

EN 14240:2004

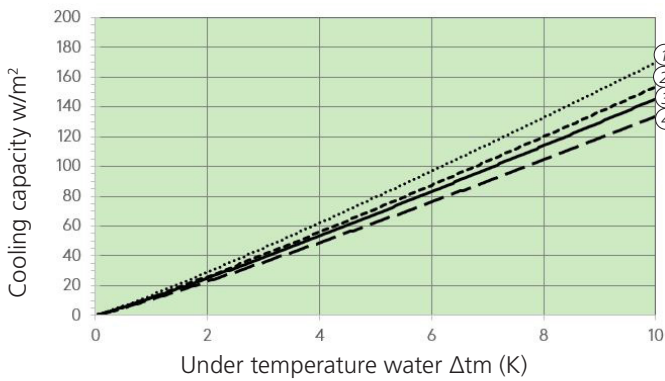

EN 14037:2016

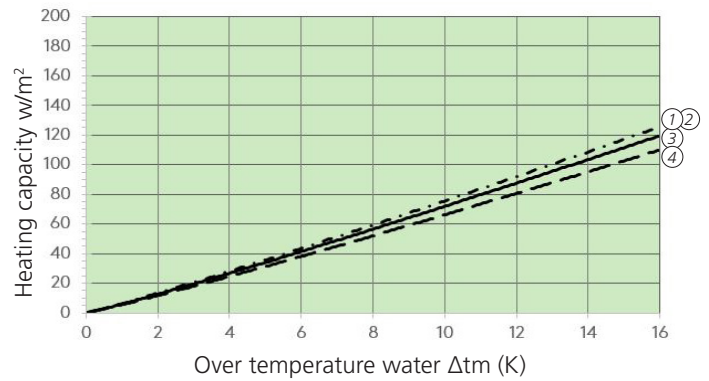

Activation	Version	Cooling 8 K	Cooling 10 K	Heating 15 K ⁽¹⁾
A11-S	① Steel + Convector Wings	up to 133 w/m ²	up to 170 w/m ²	up to 117 w/m ² (-.-.-)
A11-S	② Aluminium	up to 120 w/m ²	up to 154 w/m ²	up to 117 w/m ² (-.-.-)
A11-S	③ Steel	up to 114 w/m ²	up to 145 w/m ²	up to 112 w/m ²
Spectra M-S	④ Steel	up to 104 w/m ²	up to 133 w/m ²	up to 102 w/m ²

¹⁾ When the supply air is running, there is a 20 to 40 % higher heating capacity.

Notice

- SN EN 14240: The cooling capacity is related to the active area according to SN EN 14240:2004. The active area is calculated according to SN EN 14240 from the number of heat-conducting rails x length of heat conducting rail x distance between heat-conducting rails.
- SN EN 14037: The heating capacity is related to the active area according to SN EN 14037:2016. The active area is calculated according to SN EN 14037 from the length of the ceiling panel x the width of the ceiling panel.

Acoustics

Sound absorption (Ceiling panel)

Initial data: Radiant metal ceiling sail perforated, distance hcr 100 mm, installation height 205 mm.

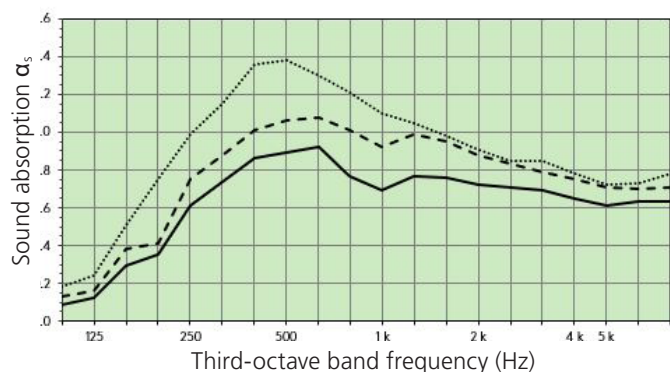

Perforation 1,5 mm – 11 %, with acoustic fleece

Additional inlay	without —————	1 strip on the long sides of cp - - - - -	Strips between hcr
Practical sound absorption α_p	250: 0,55 500: 0,90 1k: 0,75 2k: 0,75 4k: 0,65	250: 0,70 500: 1,00 1k: 0,95 2k: 0,90 4k: 0,75	250: 0,95 500: 1,00 1k: 1,00 2k: 0,90 4k: 0,80
sound absorption α_{pw}	α_w : 0,75	α_w : 0,90	α_w : 0,95
Sound absorption class	C	A	A

Sound power level L_{WA} / Pressure loss

Air volume per outlet	Air volume per nozzle with 14 nozzles	Pressure loss [Pa]	Sound power level [dB(A)]
120 m ³ /h	8.5 m ³ /h	12.3	30.7
90 m ³ /h	6.5 m ³ /h	8.8	29.2
60 m ³ /h	4.3 m ³ /h	4.6	26.9

System

Ceiling system

- Sail
 - Rectangular panels

System components

- Nozzle channel with induction nozzles

Installation systems

- Installation high: min. 205 mm
 - Hook-on systems
 - Threaded rods or ropes

Installation high

Panel height	Ø Connection nozzle	min. installation high
30 – 50 mm	100 mm	205 mm
30 – 50 mm	125 mm	230 mm
30 – 50 mm	160 mm	265 mm

Materials, weight and dimensions

Materials and weight

Activation	Material	Weight (incl. activation, water)	Building material class ⁽¹⁾ (EN 13501-1)
A11-S	Aluminium 1,00 mm	3,8 – 6,5 kg/m ²	A2-s1, d0
A11-S	Steel 0,70 mm	6,5 – 9,0 kg/m ²	A2-s1, d0
Spectra M-S	Steel 0,70 mm	10,0 – 13,3 kg/m ²	B-s2, d0

¹⁾ Also depends on the acoustic inserts.

Dimensions

Sail length	Sail width	Sail height
min. 800 mm	min. 400 mm	min. 30 mm ⁽¹⁾
project specific	max. 1200 mm	max. 50 mm

¹⁾ System structure without tolerance of the concrete ceiling.

Surface

Versions

- Powder coating
- Digital printing on request

Colors

- Standard RAL 9010
- Other RAL / NCS colors on request

Perforations

- Standard perforations
- Other perforations on request

Standard perforations:

Rd 1,5 – 11 %

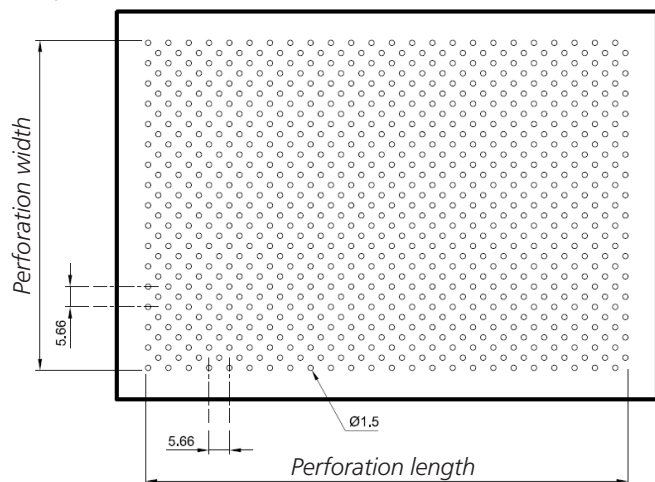

Rg 1,5 – 11 %

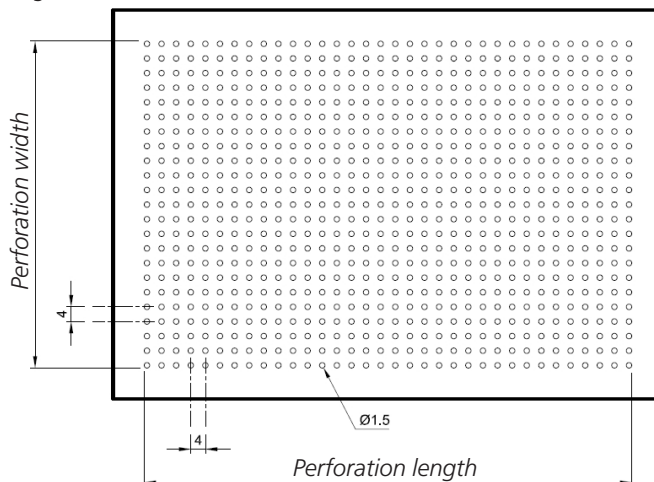

Rd 1,5 – 22 %

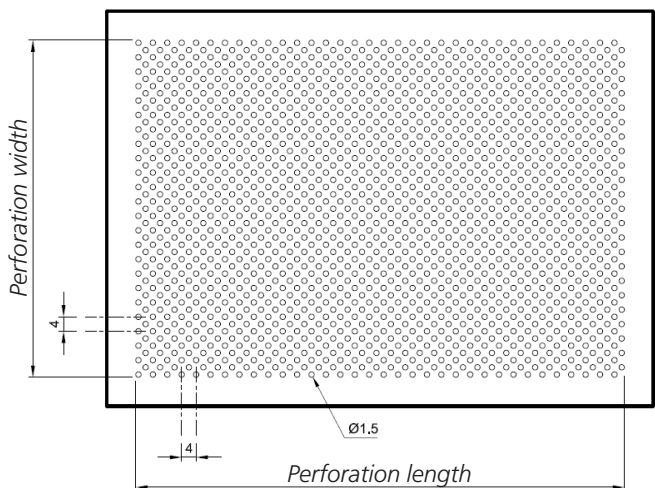

Rg 2,5 – 16 %

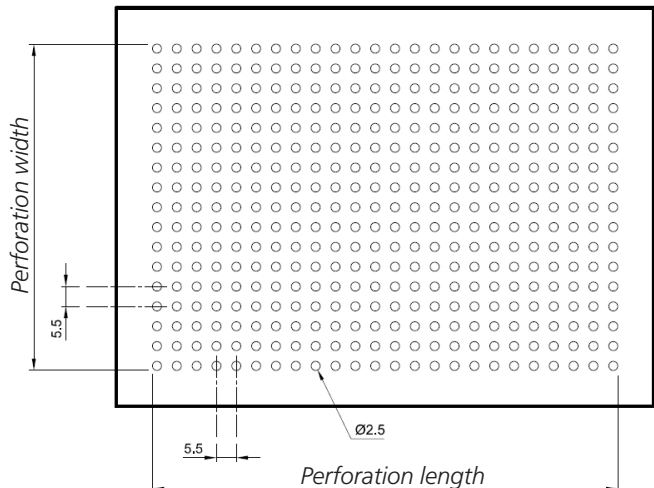

International

Barcol-Air Group AG

Wiesenstrasse 5
8603 Schwerzenbach
T +41 58 219 40 00
F +41 58 218 40 01
info@barcolair.com

Switzerland



Barcol-Air AG

Wiesenstrasse 5
8603 Schwerzenbach
T +41 58 219 40 00
F +41 58 218 40 01
info@barcolair.com

Barcol-Air AG

Via Bagutti 14
6900 Lugano
T +41 58 219 45 00
F +41 58 219 45 01
ticino@barcolair.com

Germany

Swegon Klimadecken GmbH

Schwarzwaldstrasse 2
64646 Heppenheim
T +49 6252 7907-0
F +49 6252 7907-31
vertrieb.klimadecken@swegon.de
swegon.de/klimadeckensysteme

France

Barcol-Air France SAS

Parc Saint Christophe
10, avenue de l'Entreprise
95861 Cergy-Pontoise Cedex
T +33 134 24 35 26
F +33 134 24 35 21
france@barcolair.com

Italy

Barcol-Air Italia S.r.l.

Via Leone XIII n. 14
20145 Milano
T +41 58 219 45 40
F +41 58 219 45 01
italia@barcolair.com