

MANUAL FOR ALARMS AND INFORMATION MESSAGES

GLOBAL RX/RX Top/PX/PX Top/PX LP

ESENSA RX Top/PX Top/PX Flex*

SERENITY 06/08/10

Applicable to TAC7 generation controls

* Not available in all countries. Please contact your sales representative.





Table of content

1. Alarms in TACtouch.....	3
2. Alarm table.....	4
3. Alarm groups.....	8

1. Alarms in TACtouch

The following tables summarise the error codes of alarms as reported by the TACtouch hand-held terminal together with the associated describing text. The alarm types as defined in the alarms section are indicated for each code.

- Priority alarm indication: Each alarm is represented by a symbol, on the left or the right side of the Alarms button in the Dashboard and in the Alarms screen list.
-  Prior. A - Highest/Severe alarm.
 -  Prior. B - Warning.
 -  Prior. i - Information.
- Lowest level alarms may be hidden using the parameter «Hide low level alarms» in Main setup/Commissioning settings or in Functions/Alarm settings/Low priority alarms.

Alarm Screen:
Displayed by clicking on the Alarms button in the Dashboard, shows:

- List of active alarms with their level indicator, description and start time/date. Possibility to reset active alarms.
- List of historic last 70 alarms with their level indicator, description and start/end time-date. Possibility to reset alarms history.

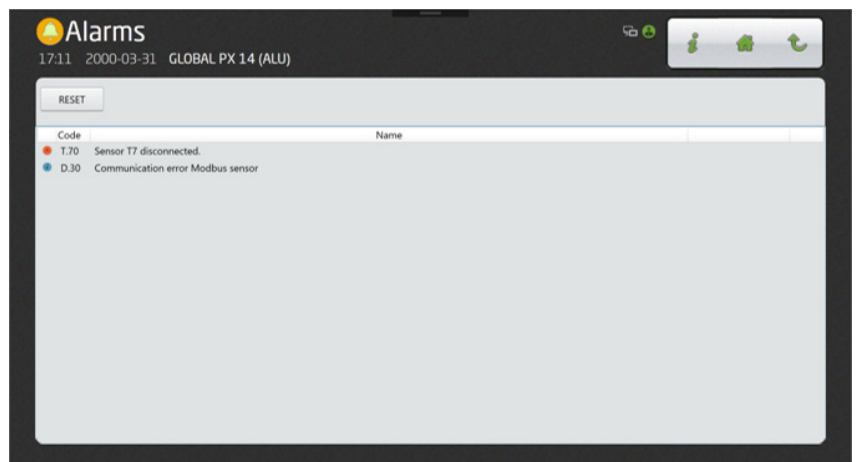

How to use the manual when an alarm appears on the TACtouch:

1. Identify the alarm number (column) on the TACtouch screen.
2. Find the corresponding number in the table, see section 2.
3. All alarm numbers are integrated in an alarm group, see table.
4. Diagnostics for each is available in section 3.

2. Alarms table

Al. N°	Alarm description	Prior.	AI DO9 status	AI DO10 status	LED ALARM	Auto Reset	Fans behavior
Alarm group 2: Fan failure alarm							
B.11	Fan 1 failure	A	ON	/	ON	NO	Stopped
B.12	Fan 2 failure	A	ON	/	ON	NO	Stopped
B.13	Fan 3 failure	A	ON	/	ON	NO	Stopped
B.14	Fan 4 failure	A	ON	/	ON	NO	Stopped
Alarm group 3: Pressure alarm							
P.10	Pressure alarm - Supply air.	B	/	ON	ON	YES	/ (stop if the status has been changed in Functions/Filters/ Pressure alarm)
P.15	Pressure alarm - Extract air.	B	/	ON	ON	YES	
S.40	Pressure alarm from Pressure Switch-Filter Supply.	B	/	ON	ON	YES	/
S.41	Pressure alarm from Pressure Switch-Filter Extract	B	/	ON	ON	YES	/
Alarm group 4: Initialisation of the reference pressure alarm							
P.20	Initialisation of the reference pressure-Unstable supply air pressure.	B	ON	/	ON	NO	Stopped
P.21	Initialisation of the reference pressure-Unstable extract air pressure.	B	ON	/	ON	NO	Stopped
P.22	Initialisation of the reference pressure-Supply air flow too low.	B	ON	/	ON	NO	Stopped
P.23	Initialisation of the reference pressure-Extract air flow too low.	B	ON	/	ON	NO	Stopped
P.24	Initialisation of the reference pressure-Supply air flow not reached.	B	ON	/	ON	NO	Stopped
P.25	Initialisation of the reference pressure-Extract air flow not reached.	B	ON	/	ON	NO	Stopped
P.26	Initialisation of the reference pressure-Supply air flow too high-Min. limit of the motor.	B	ON	/	ON	NO	Stopped
P.27	Initialisation of the reference pressure-Extract air flow too high - Min. limit of the motor.	B	ON	/	ON	NO	Stopped
Alarm group 5: Airflow mode alarm							
S.11	Constant Pressure fan 1-Pressure too low Maximum air flow reached.	B	/	/	ON	YES	/
S.12	Constant Pressure fan 1-Pressure too high - Minimum air flow reached.	B	/	/	ON	YES	/
S.13	Constant Pressure fan 3-Pressure too low Maximum air flow reached.	B	/	/	ON	YES	/
S.14	Constant Pressure fan 3-Pressure too high - Minimum air flow reached.	B	/	/	ON	YES	/
S.20	Demand control fan 1-Air flow too low - Reduce the pressure on this fan.	B	/	/	ON	YES	/
S.21	Demand control fan 1-Air flow too high - Minimum limit of the motor reached.	B	/	/	ON	YES	/
S.22	Demand control fan 2-Air flow too low - Reduce the pressure on this fan.	B	/	/	ON	YES	/

Al. N°	Alarm description	Prior.	AI DO9 status	AI DO10 status	LED ALARM	Auto Reset	Fans behavior
S.23	Demand control fan 2-Air flow too high- Minimum limit of the motor reached.	B	/	/	ON	YES	/
S.24	Demand control fan 3-Air flow too low- Reduce the pressure on this fan.	B	/	/	ON	YES	/
S.25	Demand control fan 3-Air flow too high- Minimum limit of the motor reached.	B	/	/	ON	YES	/
S.26	Demand control fan 4-Air flow too low- Reduce the pressure on this fan.	B	/	/	ON	YES	/
S.27	Demand control fan 4-Air flow too high- Minimum limit of the motor reached.	B	/	/	ON	YES	/
S.30	Constant Air Flow fan 1-Air flow too low- Reduce the pressure on this fan.	B	/	/	ON	YES	/
S.31	Constant Air Flow fan 1-Air flow too high- Minimum limit of the motor reached.	B	/	/	ON	YES	/
S.32	Constant Air Flow fan 2-Air flow too low- Reduce the pressure on this fan.	B	/	/	ON	YES	/
S.33	Constant Air Flow fan 2-Air flow too high- Minimum limit of the motor reached.	B	/	/	ON	YES	/
S.34	Constant Air Flow fan 3-Air flow too low - Reduce the pressure on this fan.	B	/	/	ON	YES	/
S.35	Constant Air Flow fan 3-Air flow too high - Minimum limit of the motor reached.	B	/	/	ON	YES	/
S.36	Constant Air Flow fan 4-Air flow too low - Reduce the pressure on this fan.	B	/	/	ON	YES	/
S.37	Constant Air Flow fan 4-Air flow too high - Minimum limit of the motor reached.	B	/	/	ON	YES	/
Alarm group 6: Control board alarm							
D.10	Program Error	A	ON	/	ON	NO	Stopped
D.20	Data Error	A	ON	/	ON	NO	Stopped
Alarm group 7: Fire alarm							
F.10	Fire alarm	A	ON	/	ON	NO	The fans run by default in the event of a fire alarm at the configured fixed airflows. The fans may be forced to stop in case of fire alarm thanks to contact IN7 and IN8 for supply and exhaust respectively (need to be closed)
F.11	End of the fire alarm	A	ON	/	ON	NO*	These contacts are available on optional satellite board SAT IO
Alarm group 8: Standard T° sensor alarm							
T.10	Sensor T1 disconnected.	A	ON	/	ON	NO	/
T.11	Sensor T1 short circuit.	A	ON	/	ON	NO	/
T.20	Sensor T2 disconnected.	A	ON	/	ON	NO	/
T.21	Sensor T2 short circuit.	A	ON	/	ON	NO	/
T.30	Sensor T3 disconnected.	A	ON	/	ON	NO	/
T.31	Sensor T3 short circuit.	A	ON	/	ON	NO	/

* Unless parameter "Fire Alarm auto reset" is set in Functions/Alarm settings

Al. N°	Alarm description	Prior.	AI DO9 status	AI DO10 status	LED ALARM	Auto Reset	Fans behavior
Alarm group 9: Option T° sensor alarm							
T.40	Sensor T4 disconnected.	A	ON	/	ON	NO	/
T.41	Sensor T4 short circuit.	A	ON	/	ON	NO	/
T.70	Sensor T7 disconnected.	A	ON	/	ON	NO	/
T.71	Sensor T7 short circuit.	A	ON	/	ON	NO	/
T.80	Sensor T8 disconnected.	A	ON	/	ON	NO	/
T.81	Sensor T8 short circuit.	A	ON	/	ON	NO	/
Alarm group 10: Anti-freeze protection alarm							
A.40	Anti-freeze protection of the internal reheater (IBA)	A	ON	/	ON	NO	Stopped
A.41	Anti-freeze protection of the waterborne reheater (EBA+)	A	ON	/	ON	NO	Stopped
A.42	Anti-freeze protection of the waterborne recoler (EBA-)	A	ON	/	ON	NO	Stopped
A.43	Anti-freeze protection of the waterborne reversible coil (EBA+-)	A	ON	/	ON	NO	Stopped
Alarm group 11: Defrost alarm							
A.20	Defrost	i	ON	/	ON	YES	Supply stopped
Alarm group 12: Anti-freeze - setpoint reduction alarm							
A.10	Pre-heating - Reduction	B	/	/	ON	YES	Reduction on both fans by steps
A.21	Anti-freeze - Reduced supply air flow (PX)	i	/	/	ON	YES	Reduction of supply fan linearly
A.23	Anti-freeze - Reduced rotor speed (RX)	i	/	/	ON	YES	/
Alarm group 13: Anti-freeze - setpoint stop alarm							
A.11	Pre-heating - Off	A	ON	/	ON	NO	Stopped
A.22	Anti-freeze - Stop supply air flow (PX)	A	/	/	ON	NO	Supply stopped
Alarm group 14: Cold climate pre-heater alarm							
E.10	Alarm Cold climate pre-heater setpoint at start-up	i	ON	/	ON	YES	/
E.11	Alarm Cold climate pre-heater setpoint with fans on	i	ON	/	ON	YES	/
Alarm group 15: Bypass alarm							
B.20	Position of the modulating bypass incorrect	A	ON	/	ON	NO	Stopped
Alarm group 16: Rotary exchanger alarm							
B.30	Speed of rotation of the exchanger incorrect	A	ON	/	ON	NO	Stopped
Alarm group 17: Supply T° sensor alarm							
T.50	Sensor T5 disconnected	A	ON	/	ON	NO	/
T.51	Sensor T5 short circuit	A	ON	/	ON	NO	/
Alarm group 18: Reheating alarm							
S.50	Reheating - T° of the supply air too low	i	/	/	ON	YES	/
Alarm group 19: Supply air temperature alarm							
S.65	Supply air T° too low - Fan stopped	A	ON	/	ON	NO	Stopped

Al. N°	Alarm description	Prior.	AI DO9 status	AI DO10 status	LED ALARM	Auto Reset	Fans behavior
Alarm group 20: Recooling alarm							
S.60	Recooling - T° of the supply air too high	i	/	/	ON	YES	/
Alarm group 21: Modbus sensor alarm							
D.30	Modbus sensor communication error	1	/	/	ON	YES	/
Alarm group 22: Maintenance alarm							
M.10	3-month maintenance	i	/	/	ON	Via reset of hours	/
M.11	12-months maintenance	i	/	/	ON	Via reset of hours	/
Alarm group 23: Operating hours alarm							
M.21	Operating hours.	B	ON	/	ON	No and reset of hours needed	/
M.22	Operating hours - AHU off.	A	ON	/	ON	No and reset of hours needed	Stopped
Alarm group 24: Condensate tray alarm							
R.10	Condensate tray full.	A	ON	/	ON	YES	Stopped
Notification							
S.70	0-10V signal < Vlow - Fan stopped.	i	/	/	ON	YES	/(stop if settings has been changed in Functions/Air flow/Stop fans outside limits)
S.71	0-10V signal > Vhigh - Fan stopped.	i	/	/	ON	YES	

3. Alarm group

Alarm group 1: Alarm indicating a communication breakdown between the control board and TACtouch

In addition to the alarms generated by the TAC control board, the TACtouch indicates communication errors icon in the header. In this case, follow these steps to diagnose the problem until that the communication has been restored:

- The cable is connected properly to the control board on connector RJ1.
- If an extension cable is used, try to invert the 2 communication wires A+ and B- , and, if there is still no communication, try with the original cable.
- Check that the contacts of the green connector on the TACtouch back cover is properly screwed into place.
- Upgrade to latest version (instruction manual and latest software version is available on the Swegon website).
- Configuration check: Go to Functions/Communication/Connection Setup and check that Parameter "TACtouch master" = "Yes" and that parameter "TAC Modbus address" has the correct value (1 by default). This is the default configuration. However, for installations where the TACtouch is slave for the communication or where it has to use a specific address as slave, then enter the correct values for the corresponding parameters. Finally, check that parameters for bus RJ1 in Functions/Communication/BUS correspond to the default settings or the actual configuration (this operation must be done using the TACsimulator interface).
- Replace the TACtouch or the control board TAC7: test the communication if possible with another TACtouch or with TACsimulator application and adapter cable connected to RJ1 (see dedicated sheet in user wiring diagram on the Swegon website). Check if the communication is correct, if yes, the problem is linked to the original TACtouch which must be replaced. If there is still no communication, then the control board TAC7 has to be replaced.

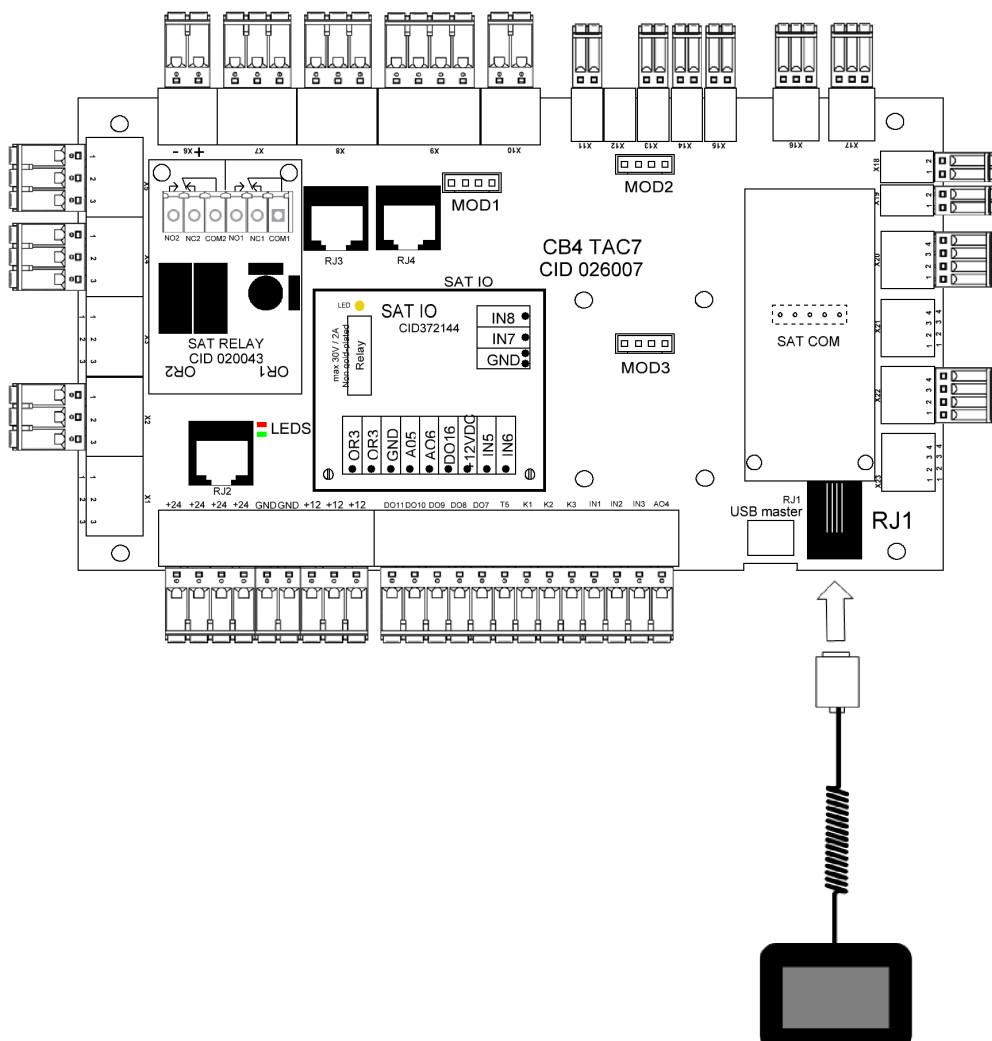

Alarm group 2: Alarm indicating a fan failure

Causes: Failure of fan. This problem is usually caused by the fan motor. If not, the failure may be caused by an internal cable (control or power) or by the TAC control board.

Diagnostic:

If both fans are in alarm: check the power supply on each fan.

If only one fan is in alarm, power down the control board and invert the fans' control cables on the control board and reset the board:

- If the alarm text now indicates the other fan, the problem is located in the fan level originally indicated as faulty, or in the control cable or the wiring of at fan connector side.
- Otherwise, if the alarm text indicates the same fan, then the control board is probably faulty due to input or output failure.

Alarm group 3: Alarm on the pressure variation

Conditions:

Mode airflow control or demand control. The unit must have forward fans or backward fans with kit CA.

External pressure switch connected on ADI2 or ADI3 input.

Causes:

Pressure alarm setup in airflow control or demand regulation mode.

External pressure switch connected on ADI2 or ADI3 input has triggered.

Alarm group 4: Alarm report during reference pressure initialisation

Conditions:

Mode Airflow control or Demand control: during the initialisation of the pressure alarm.

Mode Pressure control: during the initialisation of the reference pressure via airflow.

Causes:

The reference pressure (Pa ref) cannot be identified, and the fans are stopped.

4 possibilities:

1. Actual airflow < requested airflow: The requested working point is 'too high' (pressure loss is too high) for the maximal available pressure at the requested airflow for this fan.
2. Actual airflow > requested airflow: the nominal airflow requested to initialise the pressure alarm cannot be reached because the lower limit of the fan's operating zone has been reached.
3. Very unstable pressure (pumping).
4. Assigned airflow not reached after 3 minutes.

If this occurs during initialising a pressure alarm is triggered, there are 2 options:

1. No action is taken: the control will operate without a pressure alarm.
2. Corrective action is taken: change the working point to one location within in the working zone of the fan, by reducing the pressure system, modifying the nominal airflow.... After that, restart the setup operation.

If this occurs during initialising of the assignment pressure in pressure regulation, there are some options:

Corrective action must be taken: change the working point to another location within in the working zone of the fan, reduce the pressure system, modify the nominal airflow,.... After that, restart the setup operation.

Alarm group 5: Alarm indicating the system cannot fulfil the setpoint

The setpoint cannot be fulfilled because the upper or lower limit of the fan's working zone has been reached.

Alarm group 6: Alarm indicating a data failure in the control board

Crucial data from the control board has been lost.

Try a TOTAL RESET to restore the lost data. If still not resolved, order and replace the main control board.

Alarm group 7: Fire alarm

Conditions:

The fire alarm input must be connected to a fire detection system.

Causes:

Activation of fire alarm input, IN1, connected to a fire detection system. IN1 can be configured to work as N.O. (Normally Open) contact by default or as N.C. (Normally Closed) if desired. If the contact switches back to the original non active state, the alarm "End of fire alarm" will be triggered. Provided that the parameter "Fire Alarm auto reset" is not set to "Yes" in "Functions/Alarm Settings/Fire alarm".

Alarm group 8: Alarm indicating a temperature sensor T1/T2/T3 failure

One or more of the temperature sensors T1/T2/T3 connected to the control board that are fitted to the heat exchanger are defective or not connected. These sensors are needed for the bypass control and the anti-frost procedure.

Alarm group 9: Alarm indicating failure on temperature sensor T4/T7/T8

Conditions:

External waterborne coil option (IBA or EBA/EBA-/EBA+/-/EBAin).

Causes:

The temperature sensor located on the coil and connected to the control board is defective (open or short circuited) or not connected. Temperature sensors to consider are T7 for reheating IBA or EBA, T8 for post-cooling or reversible and T4 for pre-heating. These are used to prevent frosting of the waterborne coil. In this case, as a safety measure, the 3-ways valve is opened and the circulator contact is closed.

Alarm group 10: Alarm indicating waterborne coil anti-frosting alert

Conditions:

Only with waterborne internal coil (IBA), or external (EBA).

Causes:

Indicates that the anti-frost protection temperature of the waterborne coil is lower than 4°C. This threshold is configurable. It is important to reduce this setting for the external coil (EBAin) coil if anti-freeze fluid (Glycol) is present in the hydraulic system. The 3-ways valve is automatically opened at 100% for 15 minutes and the heating demand contact is closed (output DO7). If the air handling unit is running, the alarm is activated after 2 minutes for a pre-heater and immediately for the others. If the air handling unit is not running, the alarm is activated after 5 minutes.

Alarm group 11: Alarm indicating that the defrost process is active

Conditions:

Unit with counter flow heat exchanger.

Causes:

The ice forming inside of the plate heat exchanger is generating a pressure drop that is too high for the current airflow. This detection requires a Modbus pressure sensor placed on the heat exchanger.

When the previous detection is not available, the supply temperature is checked and if it falls below 11°C, the alarm is triggered. Cause is due to the ice that reduces the heat exchangers efficiency.

Alarm group 12: Alarm indicating heat exchanger anti-frosting alert

- For units with counter flow heat exchanger:

With anti-frost protection of the heat exchanger by supply airflow reduction:

Associated alarm code: A.21.

When the temperature of exhaust air at the exchanger output (T3) is lower than 5°C, the setpoint for the supply airflow is reduced in a linear way from 100% to, at 1°C, 33% (CA, TQ, LS mode) or 50% (CP mode) in respect of the current setpoint. High and low temperatures of 5°C and 1°C are configurable.

With pre-heating option (KWin or EBAin):

Associated alarm code: A.10.

Once 100% of the power is sent to the pre-heater and T3 (exhaust temperature) is lower than anti-frost temperature (temperature AF, 1°C by default), then both flows will be reduced in steps until T3 exceeds temperature AF or that 33% of the airflows are reached before the reduction. In this last case, a defrost process is entered for 30 minutes: pre-heater and supply will be stopped while exhaust will be at its level before reduction. After the defrost period, the anti-frost process will restart with pre-heater at 100% and both flows at 33%. During airflow reduction, if T3 becomes higher than temperature AF, the flows will increase at same rate as for reduction.

- For units with rotary heat exchanger

Associated alarm code: A.23.

When external temperature (T1 sensor) is lower than the anti-frost temperature (temperature AF, -9°C by default), the rotation speed of the heat exchanger will decrease (2RPM by default, configurable) to avoid any risk of frosting in the rotary heat exchanger.

The rotary heat exchanger will return back to its nominal rotation speed when T1 > Temperature AF is reached for the duration of 5 minutes.

Alarm group 13: Alarm indicating heat exchanger anti-frosting alert with possible fan(s) stop

Conditions:

Plate heat exchanger (PX) units with electric pre-heating (KWin) or waterborne pre-heating (EBAin), or modulating bypass configured in anti-frost modality, or anti-frost protection with supply air flow reduction.

Causes:

- With KWin or EBAin option - associated alarm code: A.11: Certain air temperature conditions measured in the exhaust airflow after the heat recovery, can indicate that the internal electric pre-heater (KWin) or external waterborne pre-heater (EBAin) has reached its limit, the TAC control can take over to guarantee the anti-frost function. If the temperature < -5°C for 5 minutes, fans are stopped.
- With modulating bypass - associated alarm code: A.11: In frost protection, this alarm indicates that the exhaust air temperature at the exchanger output (T3 sensor) has not exceeded 1°C for 15 minutes after that the bypass has been opened at 100%. The maximum opening is limited by the parameter setting that allows 50% of the airflow to bypass the heat exchanger when there is a defrost pressure sensor present. Fans are stopped and a reset of alarms is necessary.
- Anti-frost protection with supply air flow reduction - associated alarm code: A.22: when the exhaust air temperature at the exchanger output (T3 sensor) falls under 1°C (configurable parameter), the supply fan is stopped and it will start again if T3 becomes greater than 2°C for more than 5 minutes. This additional protection can be disabled. In the TACtouch, go to Functions > Heat/Cool recovery > Anti-freeze > Anti-freeze enabled.

Alarm group 14: Cold Climate Pre-heater alarm

Conditions:

Presence of Cold Climate Pre-heater.

Causes:

- Alarm indicating that during start-up, the timeout for the Cold Climate Pre-heater to reach the setpoint temperature of the fresh air temperature after the external Cold Climate Pre-heater.
- Alarm indicating that, with fans running, the fresh air temperature after the external Cold Climate Pre-heater was too low for too long (Exceeded set parameter).

Alarm group 15: Alarm indicating a faulty position of the modulating by-pass

Conditions:

Plate heat exchanger (PX) units with modulating bypass.

Causes:

This alarm indicates that the modulating bypass has not reached the intended position within 10 seconds. The most common reason for this is a damaged positioning sensor on the bypass actuator, that has to be replaced. Other reasons may be that the control board output is damaged, implying the replacement of the board, or a mechanical blocking verified by a visual inspection of the bypass.

Diagnostic: Stop the unit, do an alarm reset, check and eventually correct actuator wiring to the control board, then check that the bypass can move physically: connect IN3 to +12V to force the bypass to open.

- If the bypass stays in closed position:

Check if there is some mechanical obstruction that causes the actuator fault, otherwise:

The actuator or the control board must be replaced.

- If the bypass opens completely:

Do several close/open cycles using IN3 to try to reproduce the alarm and check bypass position in Functions/Heat/Cool recovery/Status. If the problem cannot be reproduced, try with fans boosting.

The actuator or the control board must be replaced.

Alarm group 16: Alarm indicating an error of the heat exchanger rotation speed

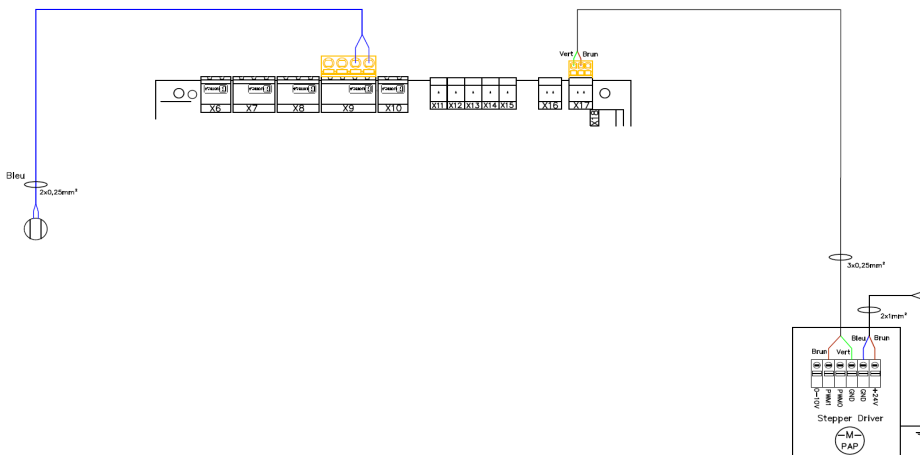

A – Visual mechanical check:

1. Check and confirm good tension of the green rubber belt in the central part of the unit. Eventually replace if broken.
2. Check and confirm good coupling between motor shaft and pulley: eventually tighten the 2 screws.
3. Check if the wires of the motor are not damaged (8 wires: red, red-white, black, black-white, green, green-white, yellow, yellow-white).

B – Further diagnostic:

1. Ensure that the control board TAC has the latest software version loaded (available on the Swegon website).
2. Check the current RPM of the rotor in relation to the setpoint under in normal conditions (no Summer night cooling and no anti-frost protection), 10 RPM.
3. If the actual speed is lower than 9.8 RPM (but >0), then decrease parameter "rotor speed at 10V" in function "Heat/cool recovery" until that the actual speed is between 9.8 and 10.2 RPM.
4. If the actual speed is higher than 10.2 RPM, then increase parameter "rotor speed at 10V" in function "Heat/cool recovery" until that the actual speed is between 9.8 and 10.2 RPM.
5. Feedback of rotor: check input for rotor speed (see wiring diagrams on the Swegon website): closed when magnet on the rotor is in front of magnetic switch. Otherwise, open.
If not, check the impedance at the sensor output: if 0 Ohm when the magnet is in front of the sensor and infinite when remote, then the sensor is correct and the control board has to be replaced. Otherwise, replace the magnetic sensor.
6. Output rotor speed control from TAC control board: check that the wire from DO2 is correctly connected to stepper driver PWM1 input (see following point).
7. Check the stepper driver: Speed should be between 9.8 and 10.2 RPM.
 - 7.1. Check that the wire from control board DO2 is correctly connected to «PWM1» input.
 - 7.2. Check and confirm +24V DC to GND, +24V connectors of stepper driver. If not, check the 24V DC power supply and the cable between the 24V power supply and the driver.
 - 7.3. Check electric connection between driver and motor.
 - 7.4. A red light blinking on the stepper driver, indicates an alarm.
Check if all supports of the stepper motor are correctly connected to the rotor frame with the yellow protective earth cable.
 - 7.4.1 If not, it must be connected, and it is safer to replace the stepper driver and the control board.
 - 7.4.2 If yes, try another driver or if the red led is still blinking, try another motor to resolve the problem.

N.B.: When the stepper driver is replaced, dip switches must be placed at the same position as indicated on the stepper driver that has been replaced. Only DIP SWITCH 1 has effect and is used for the direction of rotation.

Alarm group 17: Alarm indicating failure of temperature sensor T5

Conditions:

Only with reheating, post-cooling or Summer night cooling with heat rotary or modulating bypass option.

Causes:

Temperature sensor T5 located in the supply duct and connected to the control board is open, or short-circuited. This sensor is used to modulate the reheating or post-cooling function with activated comfort temperature control determined by T5 or to control the high and low thresholds to limit the supply air temperature with activated comfort temperature control determined by T2.

Alarm group 18: Alarm indicating that the comfort temperature is too low relative to setpoint temperature

Conditions:

Only with reheating option.

Causes:

The comfort temperature setpoint cannot be reached (actual temperature higher than the setpoint for the duration of 15 minutes, or 30 minutes if comfort determined by T2 instead of T5, while reheating is at its maximum).

Alarm group 19: Alarm indicating that the comfort temperature is too low in absolute terms

Conditions:

Only with reheating or cooling option.

Causes:

This alarm indicates that the supply temperature (T5) is lower than 5°C. The fans are stopped for 1 minute. The alarm is configurable and is disabled by default.

Alarm group 20: Alarm indicating that the comfort temperature is too high relative to setpoint temperature

Conditions:

Only with post-cooling option.

Causes:

The comfort temperature setpoint cannot be reached (actual temperature lower than the setpoint for the duration of 15 minutes, or 30 minutes if comfort is determined by T2 instead of T5, while post-cooling is at its maximum).

Alarm group 21: Alarm indicating communication error of one of the Modbus pressure sensors

Conditions:

Unit with at least one configured Modbus pressure sensor.

Causes:

One or more of the Modbus pressure sensors send too many communication errors. This in turn can come from:

- The physical absence of one of the configured sensors.
- One of sensors is not powered on: check "ON" led light of all configured sensors. See installation manual of Modbus pressure sensor.
- Faulty cable.
- One of the sensor addresses is not correctly set: check the dip switch setting of each configured sensor according to its function. See diagnostic here below.

Diagnostic:

- In TACtouch, check the communication sensor errors under Functions/Inputs/outputs/Pressure-Modbus Sensors: The Modbus pressure sensor which is in alarm will indicate errors. First, check that the sensor is installed, if not, modify the configuration instructing the control board that the sensor is not present. For that, go to Functions/Airflow/Fan/Advanced settings for pressure sensors of kit CA: OFF.
- If the sensor is installed, check if its address is correctly set. See address settings below.
- Finally, check the sensor status led: green = ON, orange blinking = valid communication. If the status led is indicating errors, then it may be due to a damaged cable or sensor. See wiring.

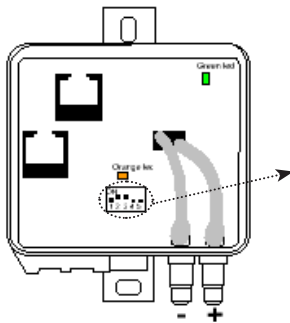

Mode	Supply	Exhaust
CP	5 	6
CA*	1 	2**
Defrost*		C
Filters*	7 	8**

* = Factory installed

** = If 2 physical sensors and not 1 dual (with dual sensor, exhaust pressure measurement uses bottom row of pipes. The ones highlighted in yellow in the picture here at right side).

GREEN LED ON: Power ON
 GREEN LED OFF: Power OFF

ORANGE LED Flashing: Valid Modbus communication
 ORANGE LED OFF: Invalid Modbus communication

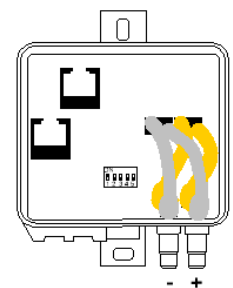

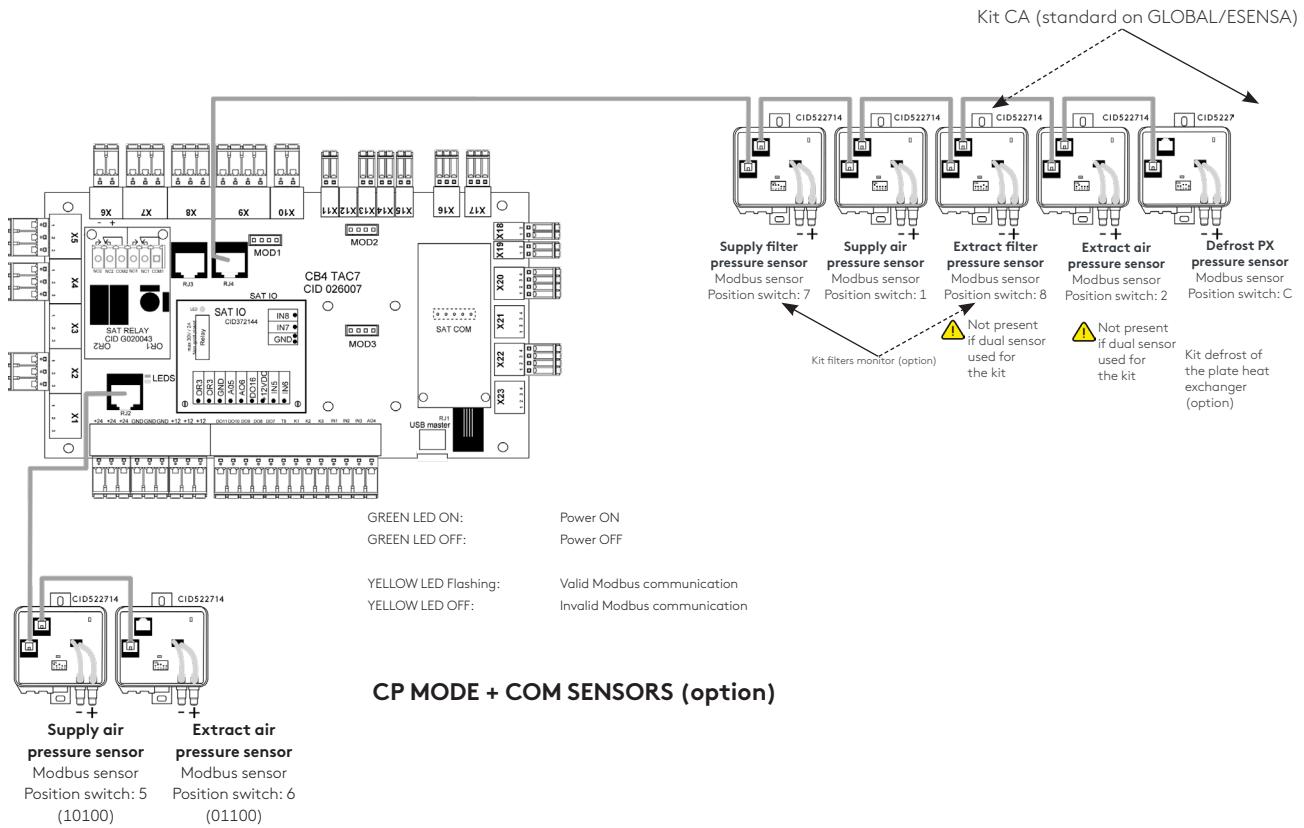

Alarm group 22: Maintenance alarm

Alarm indicating that the hour limit for minor or major maintenance has been reached.

Conditions:

The hour limit for minor or major maintenance must be configured with a value greater than 0.

Causes:

The hour limit for minor or major maintenance has been reached.

- For minor maintenance, the instructions illustrated in the manual for the 3-month maintenance should be followed and mainly, the filters should be cleaned or replaced.

Reset the hours for minor maintenance after this operation, this will reset the alarm and trigger it again after the same period. In the TACtouch, go to Functions > Filters > Periodic maintenance > Reset.

- For major maintenance, the instructions illustrated in the manual for the 12-month maintenance should be followed.

Reset the hours for major maintenance after this operation, this will reset the alarm and trigger it again after the same period. Also reset minor maintenance hours.

In the TACtouch, go to Functions > Alarm settings > Periodic maintenance - 12 monts > Reset.

Alarm group 23: Service alarm

Conditions:

The running hours feature must be enabled.

Causes:

SERVICE ALARM: the fan operating time (in hours) has exceeded the configured threshold.

STOP FAN: the fan operating time (in hours) has exceeded the configured threshold. This alarm stops the fans.

Alarm group 24: Drain pump alarm

Conditions:

Only for "GLOBAL PX LP" (Plate heat exchanger Low Profile) model or for all models that are equipped with an external coil and fitted condensate pump.

Causes:

The level of condensate is higher than the set setting (approx. 1.5 cm). It can also be activated if the pump is not present or defective.