

PERFEKT

FURAI[®]

METALLDECKEN

CEILING MANUAL

CLIP-IN SYSTEM

HANG-IN SYSTEM

LAY-IN SYSTEM

STRIP GRID SYSTEM

SUPPORT SYSTEM

SWING OUT/SLIDING CEILINGS

SPECIAL CEILINGS

FLOATING CEILINGS



04/2017

System designation:

KQK 1.1.1.1

K = KASSETTE (TILE)

Q = QUADRAT (SQUARE)

L = LANGFELD (LONG SPAN)

KQK 1.1.1.1

K = KLEMM (CLIP-IN)

H = EINHÄNGE (HANG-IN)

G = GANG (CORRIDOR)

B = BANDRASTER (STRIP GRID)

E = EIN-/AUFLAGE (LAY-IN/SUPPORT)

V = HALBVERDECKTE (SEMI-CONCEALED)

T = TIEFENPRÄGUNG (DEBOSSEMENT)

KQK 1.1.1.1

1 = CLIP-IN SYSTEM

2 = HANG-IN SYSTEM

3 = LAY-IN SYSTEM

5 = STRIP GRID SYSTEM

KQK 1.1.1.1

1 = SQUARE

2 = LONG SPAN

KQK 1.1.1.1

0 = WITHOUT GRID

1 = WITH GRID

2 = WALL MOUNTING

KQK 1.1.1.1

1 = QUICK SUSPENSION

2 = NONIUS SUSPENSION

3 = SHORT SUSPENSION

4 = WALL MOUNTING

5 = THREADED ROD

System:	Page:
CLIP-IN SYSTEM	4 - 23
HANG-IN SYSTEM	24 - 35
LAY-IN SYSTEM	36 - 43
STRIP GRID SYSTEM	44 - 53
SUPPORT SYSTEM	54 - 61
SWING OUT / SLIDING CEILINGS	62 - 67
SPECIAL CEILINGS	95 - 103
FLOATING CEILINGS	104 - 111

Function:

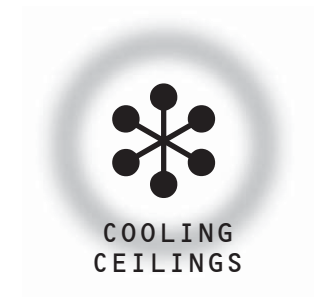

Formats:

Page:

Long span CLIP-IN	101
Long span STRIP	102

Long span corridor	96
Sealed square	98
Long span room	99

Square + nonius suspension	10
Square + short suspension	11
Long span + nonius suspension	18
Long span + short suspension	19

For all systems, in addition we offer:



Wall connections	69 - 75
Details/supplies	79 - 93
Surface design/perforation/absorption	112 - 115
Basic notes to EN 13964	76 - 77
13 good reasons	116 - 117
Help, counselling	123

ADVANTAGES OF THE CLIP-IN SYSTEM:

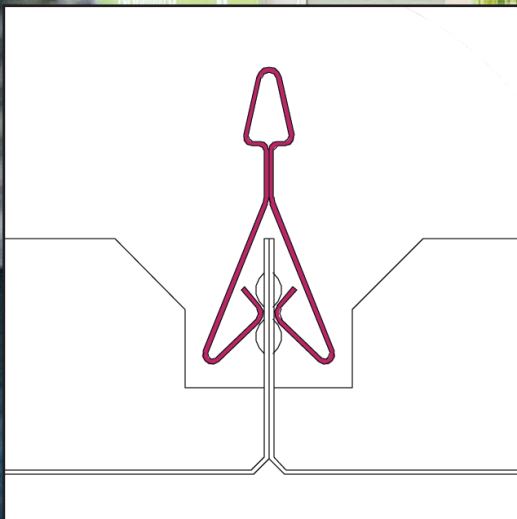

> Excellent visual impression

- No faulty alignment or distorted tile joints, stress-free installation
- No level difference - precision double clipping knobs



> Little waste:

- Square tiles – all 4 webs with clipping knobs
- Clipping rails – residues can be used for longitudinal connection

> Minimum logistics requirements:

- Same type of rail used as clipping rail and grid rail
- Free positioning of suspension elements on the bare ceiling
- The clipping rail can also be mounted onto an existing T-rail



CLIP-IN SYSTEM

Format:	Grid:	Suspension:	Function:	Code:	Page:
Square	with grid	wire 4 mm	(DOOR)	KQK - 1.1.1.1	6
Square	without grid	wire 4 mm	(DOOR)	KQK - 1.1.0.1	7
Square	with grid	short suspension	(DOOR)	KQK - 1.1.1.3	8
Square	without grid	short suspension	(DOOR)	KQK - 1.1.0.3	9
Square	with grid	nonius suspension	ball	KQK - 1.1.1.2 BWS	10
Square	with grid	short suspension	ball	KQK - 1.1.1.3 BWS	11
Long span	without grid	wire 4 mm	room	KLK - 1.2.0.1	12
Long span	without grid	short suspension	room	KLK - 1.2.0.3	13
Long span	with grid	wire 4 mm	room	KLK - 1.2.1.1	14
Long span	wall mounting	wall bracket	corridor	KLK - 1.2.2.3	15
Long span	wall mounting	angle	corridor	KLK - 1.2.3.4	16
Long span	without grid	nonius suspension	ball	KLK - 1.2.0.2 BWS	18
Long span	without grid	short suspension	ball	KLK - 1.2.0.3 BWS	19
Joins					20
Edges and webs					21
Wide-span girders					22
Installation					23
Wall connection					69

Further information on the requirements of EN 13964 according to CE standard mark

76 - 77

**KQK
1.1.1.1**

FURAL® Acoustic Ceilings
Square tiles – clip-in system

Standard design with double grid - quick suspension element

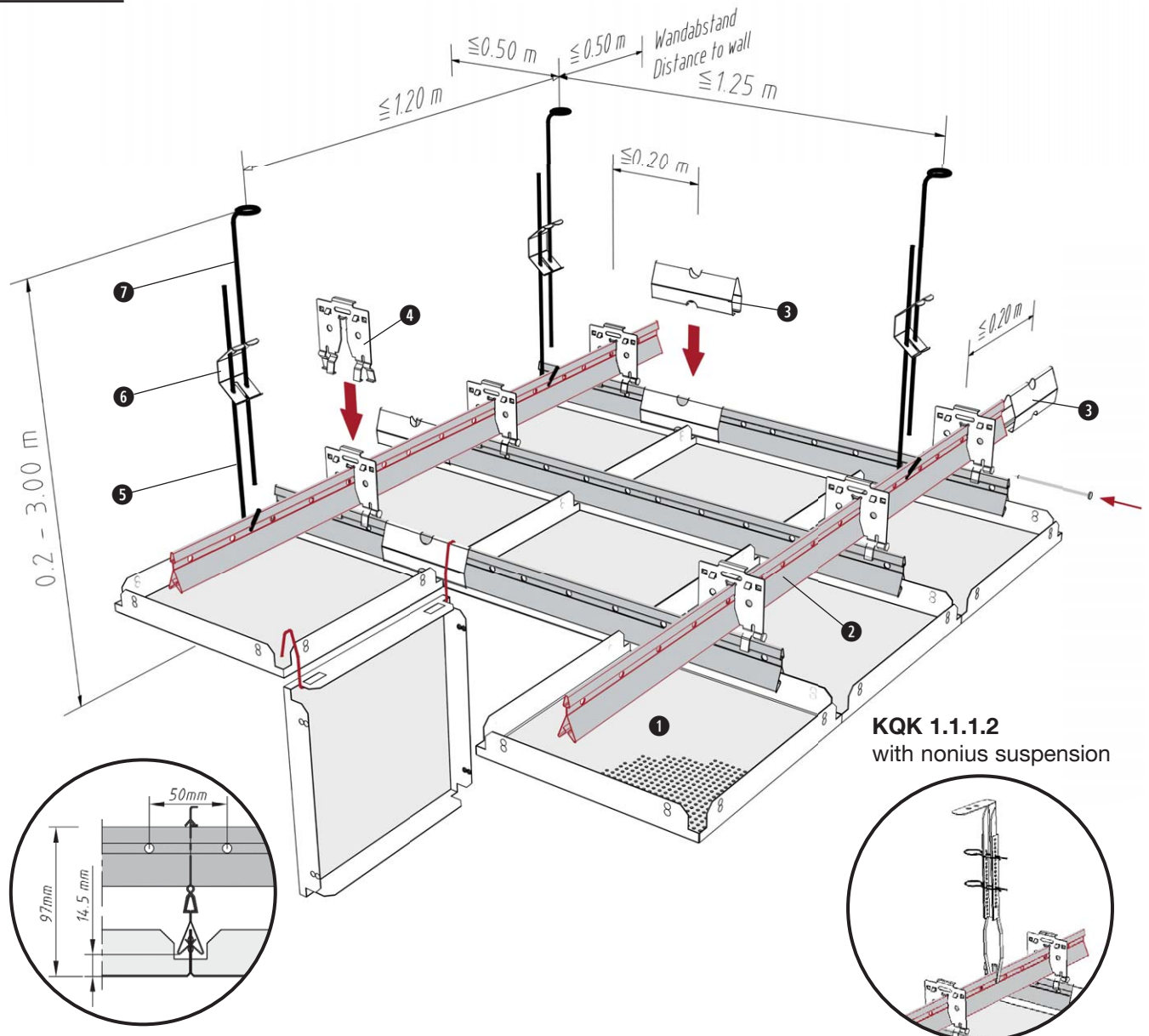

KQK 1.1.1.2
with nonius suspension

Stress-free, quick installation - clean visual impression!

Installation

Distance between fixing points according to the sketch

Ceiling weight per m²: alu app. 5 kg,
 steel app. 8 kg

further instructions: p. 23 and p. 76-77

Standard components

required: KQK 1.1.1.1

Item	Designation	Quantity / m ²		
		750	625	600
①	Ceiling tile	1.78	2.56	2.78 units
②	Clipping rail 16/38	2.13	2.40	2.47 metres
③	Main runner connector	0.53	0.60	0.62 units
④	Suspension key + security pin 1.07	1.28	1.28	1.33 units
⑤	Suspension wire with hook	0.67	0.67	0.67 units
⑥	Spring bracket	0.67	0.67	0.67 units
⑦	Suspension wire with loop	0.67	0.67	0.67 units

**KQK
1.1.0.1**

FURAL® Acoustic Ceilings
Square tiles – clip-in system

Standard design without double grid - quick suspension element

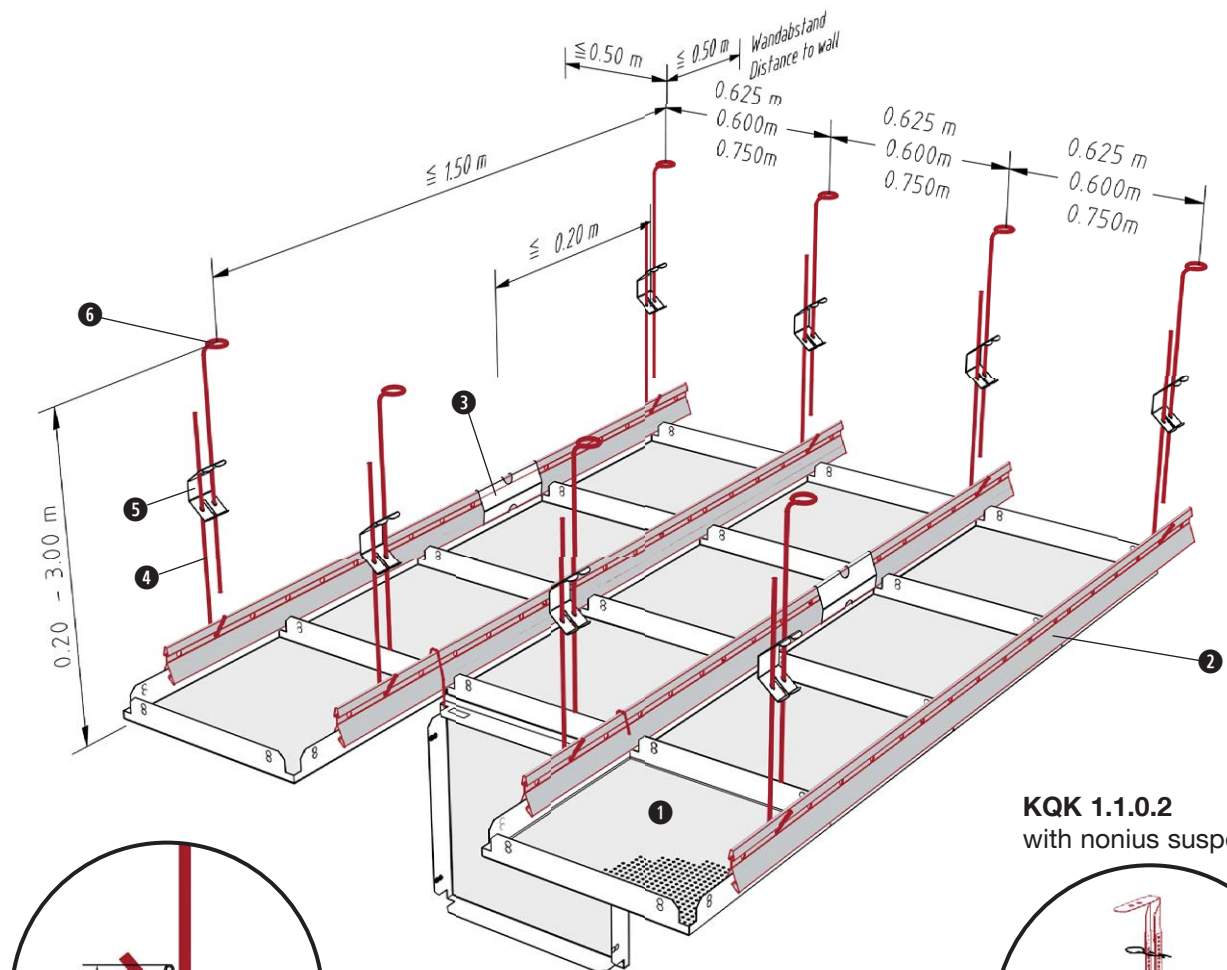

KQK 1.1.0.2
with nonius suspension

Requirements:

- a) Suspension elements must be mounted onto the bare ceiling accurately at a distance equivalent to the length of tiles (locations marked by laser)
- b) Accurate height adjustment at each suspension element.

The most cost-efficient solution!

Installation

Distance between fixing points according to the sketch

Ceiling weight per m²: alu ca. 4 kg,
 steel app. 7 kg

further instructions: p. 23 and p. 76-77

Standard components required: KQK 1.1.0.1

Item	Designation	Quantity / m ²			
		750	625	600	
①	Ceiling tile	1.78	2.56	2.78	units
②	Clipping rail 16/38	1.33	1.60	1.67	metres
③	Main runner connector	0.33	0.40	0.42	units
④	Suspension wire with hook	0.89	1.07	1.11	units
⑤	Spring bracket	0.89	1.07	1.11	units
⑥	Suspension wire with loop	0.89	1.07	1.11	units

KQK 1.1.1.3

FURAL® Acoustic Ceilings Square tiles – clip-in system

Standard design with double grid - low suspension height

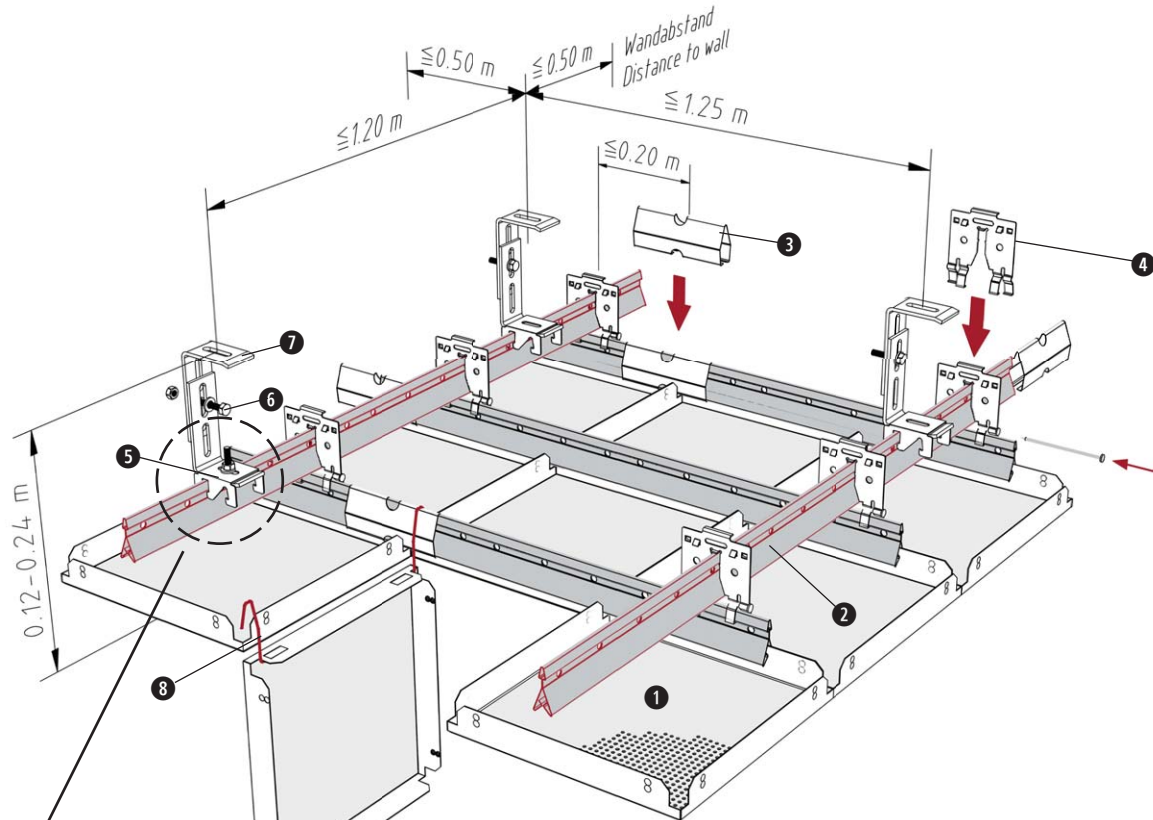

Screw fastening:
1 x every 5 m² ceiling area,
but at least 2 x per room in
the case of smaller areas

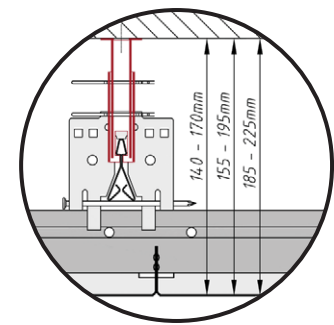
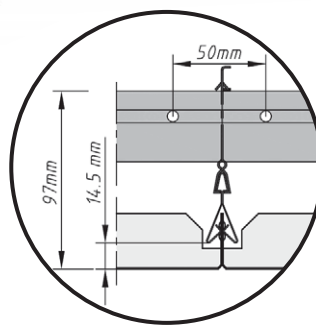

Version: with nonius short suspension

*Clean visual impression even
at lowest suspension height.*

Installation

Distance between fixing points
according to the sketch

Ceiling weight per m²: alu app. 5 kg,
 steel app. 8 kg

further instructions: p. 23 and p. 76-77

Standard components required: KQK 1.1.1.3

Item	Designation	Quantity / m ²		
		750	625	600
①	Ceiling tile	1.78	2.56	2.78 units
②	Clipping rail 16/38	2.13	2.40	2.47 metres
③	Main runner connector	0.53	0.60	0.62 units
④	Suspension key + security pin	1.07	1.28	1.33 units
⑤	Fixing plate	0.67	0.67	0.67 units
⑥	Screw M6, complete	0.67	0.67	0.67 units
⑦	Universal fastening bracket	1.34	1.34	1.34 units
⑧	DOOR-wire bracket	3.56	5.12	5.56 units

**KQK
1.1.0.3**

FURAL® Acoustic Ceilings
Square tiles – clip-in system

Standard design without double grid - minimum suspension height

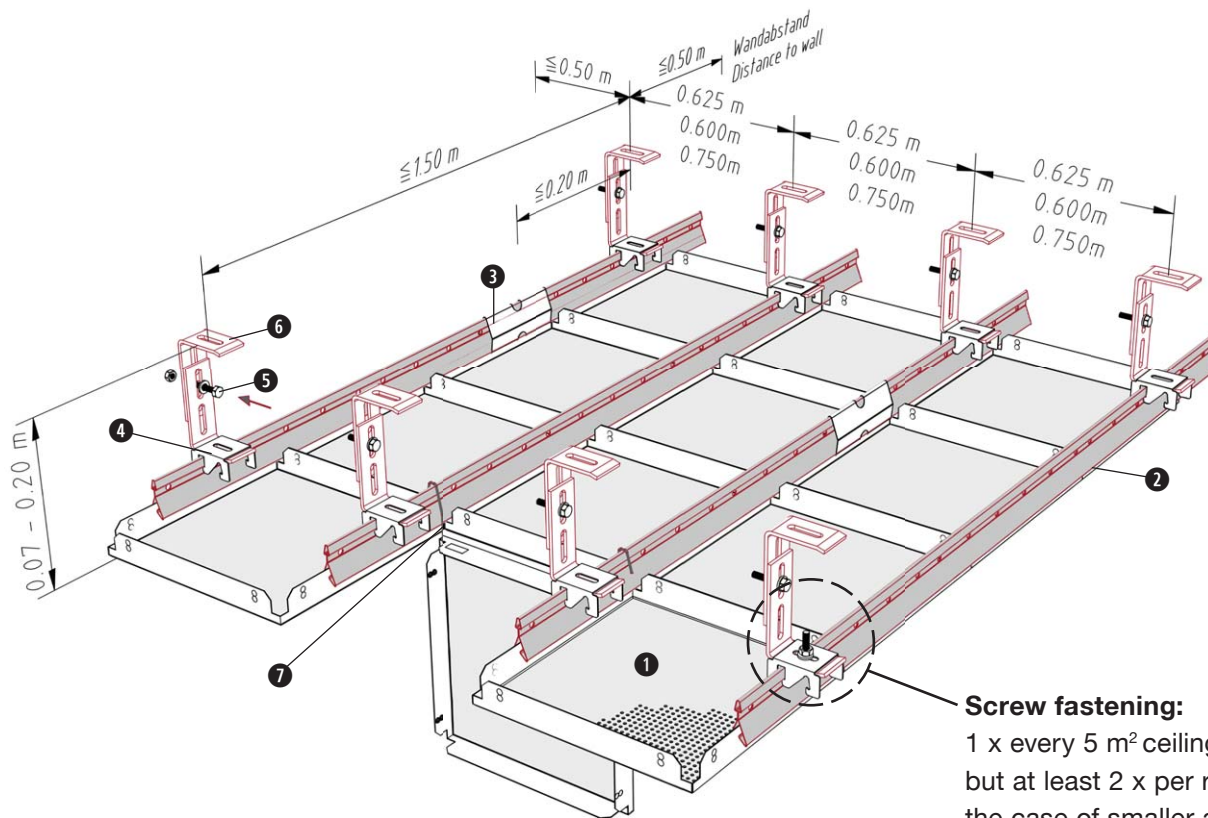

Screw fastening:
1 x every 5 m² ceiling area,
but at least 2 x per room in
the case of smaller areas

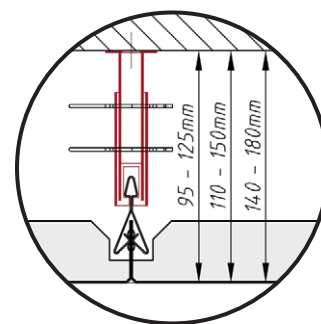
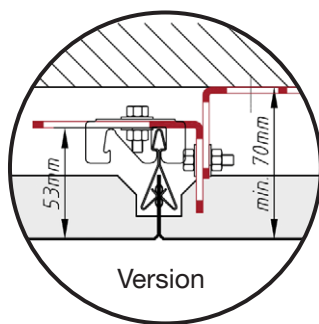
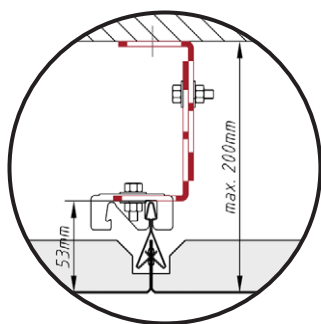

Version: with nonius short suspension

Lowest suspension height - simply unbeatable!

Installation

Distance between fixing points
according to the sketch

Ceiling weight per m²: alu app. 4 kg,
 steel app. 7 kg

further instructions: p. 23 and p. 76-77

Standard components

required: KQK 1.1.0.3

Item	Designation	Quantity / m ²			
		750	625	600	
①	Ceiling tile	1.78	2.56	2.78	units
②	Clipping rail 16/38	1.33	1.60	1.67	metres
③	Main runner connector	0.33	0.40	0.42	units
④	Fixing plate	0.89	1.07	1.11	units
⑤	Screw M6, complete	0.89	1.07	1.11	units
⑥	Universal fastening bracket	1.78	2.14	2.22	units
⑦	DOOR-wire bracket	3.56	5.12	5.56	units

KQK 1.1.1.2 BWS

FURAL® Acoustic Ceilings Square tiles – clip-in system

Ball-proof ceiling - with nonius suspension

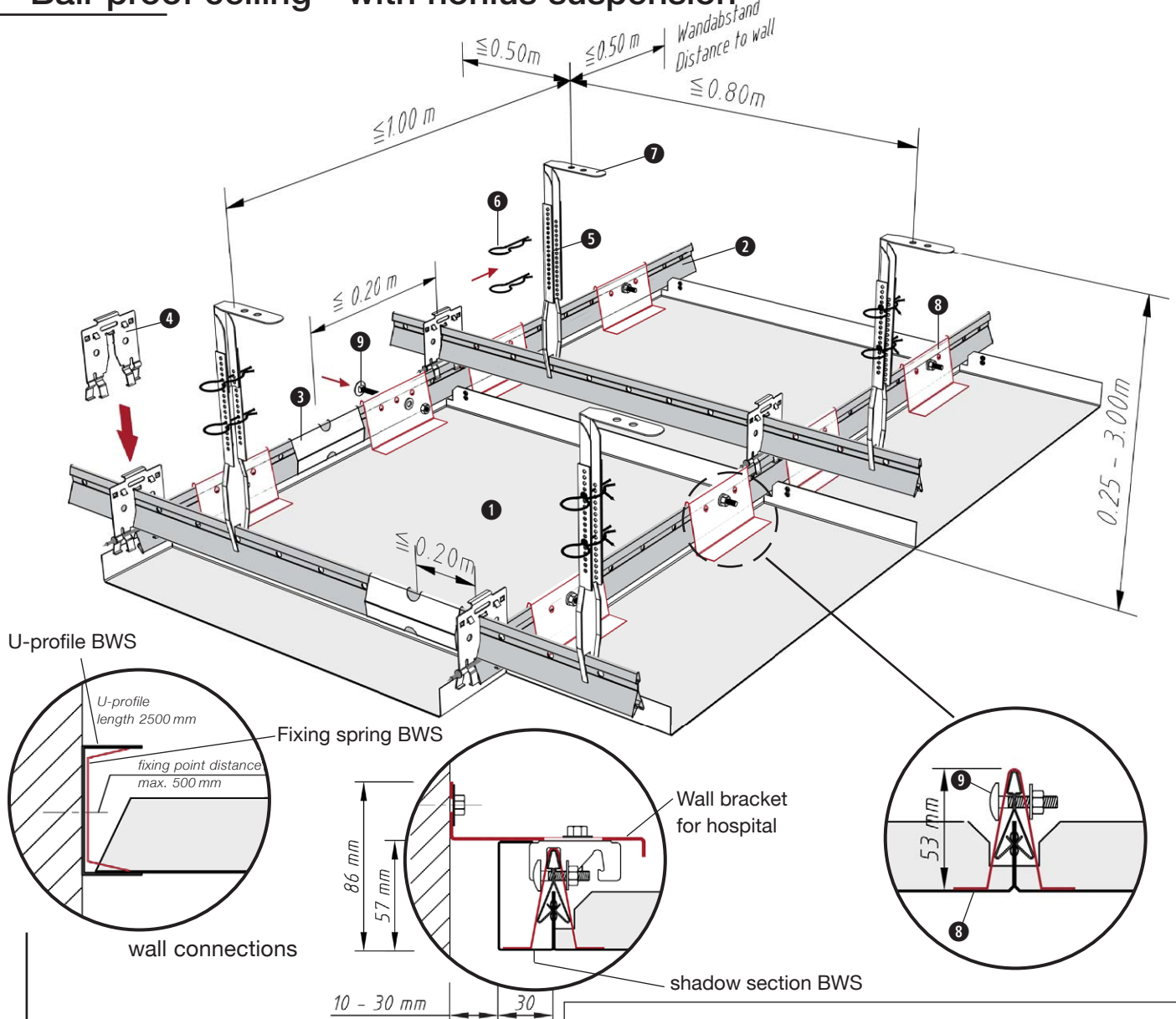

The proven standard design with the additional benefits of being ball-proof and providing maximum sound absorption. Test certificate according to DIN 18032, Part 3 & EN 13964 attachment D.

Installation

Distance between fixing points according to the sketch
Ceiling weight per m² steel app. 8kg
further instructions: p. 23 and p. 76-77

Standard components

required: KQK 1.1.1.2 BWS

Item	Designation	Quantity / m ²		
		625	600	
①	Ceiling tile	2.56	2.78	units
②	Clipping rail 16/38	2.60	2.67	metres
③	Main runner connector	0.65	0.67	units
④	Suspension key + security pin	1.60	1.67	units
⑤	Lower nonius	1.25	1.25	units
⑥	Securing pin	2.50	2.50	units
⑦	Upper nonius	1.25	1.25	units
⑧	Supporting bracket	5.12	5.56	units
⑨	Mushroom head bolt (square necked)	5.12	5.56	units

KQK 1.1.1.3 BWS

FURAL® Acoustic Ceilings Square tiles – clip-in system

Ball-proof ceiling - with short suspension

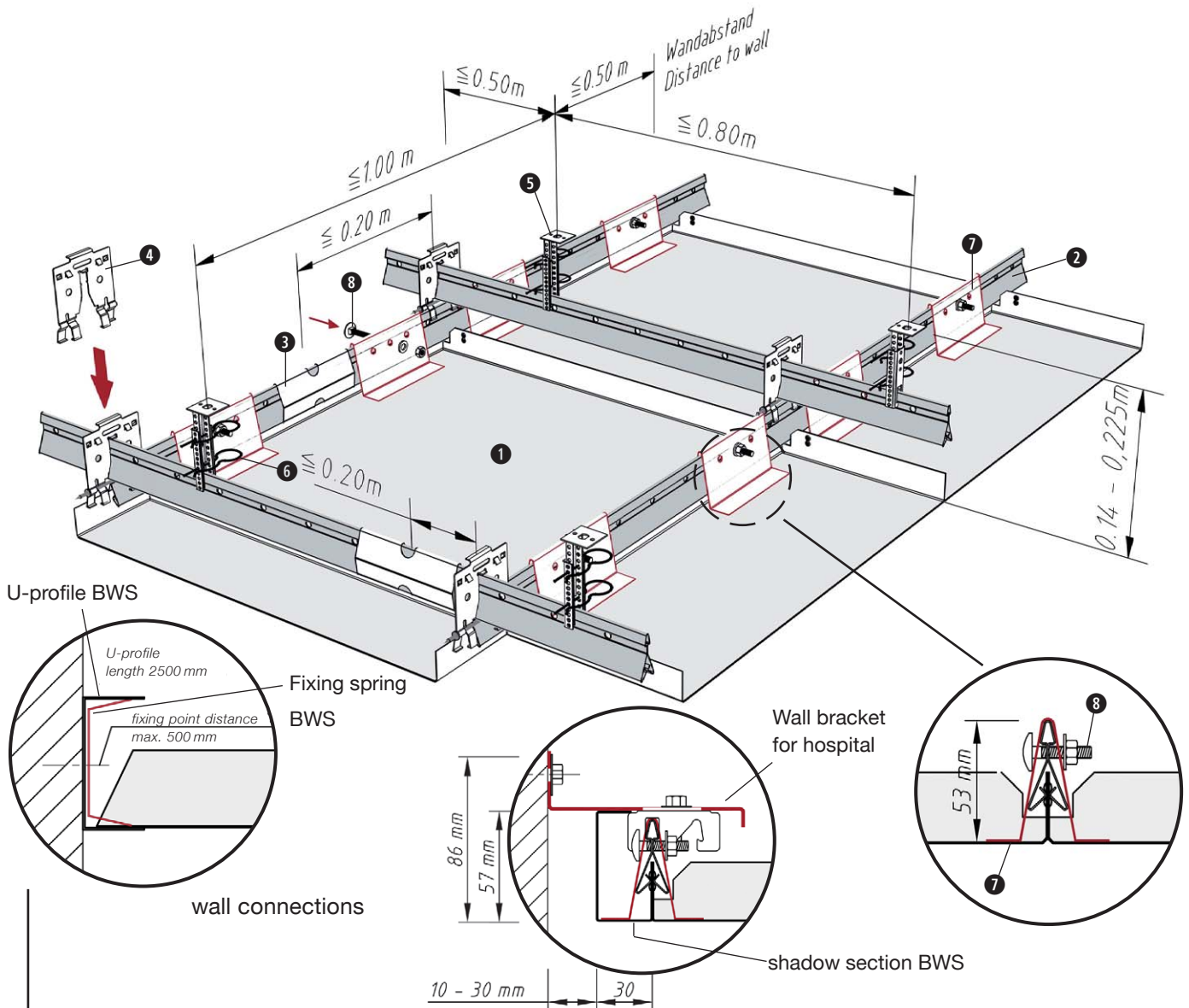

Ball-proof design even at minimum suspension height and maximum sound absorption. Test certificate according to DIN 18032 Part 3 & EN 13964 attachment D.

Standard components

required: KQK 1.1.1.3 BWS

Item	Designation	Quantity / m ²	
		625	600
①	Ceiling tile	2.56	2.78 units
②	Clipping rail 16/38	2.60	2.67 metres
③	Main runner connector	0.65	0.67 units
④	Suspension key + security pin	1.60	1.67 units
⑤	Upper and lower nonius (set)	1.25	1.25 units
⑥	Securing pin	2.50	2.50 units
⑦	Supporting bracket	5.12	5.56 units
⑧	Mushroom head bolt (square necked)	5.12	5.56 units

Installation

Distance between fixing points according to the sketch
 Ceiling weight per m² steel app. 8kg
 further instructions: p. 23 and p. 76-77

KLK 1.2.0.1

FURAL® Acoustic Ceilings Long span tiles – clip-in system

Standard design without double grid - quick suspension element

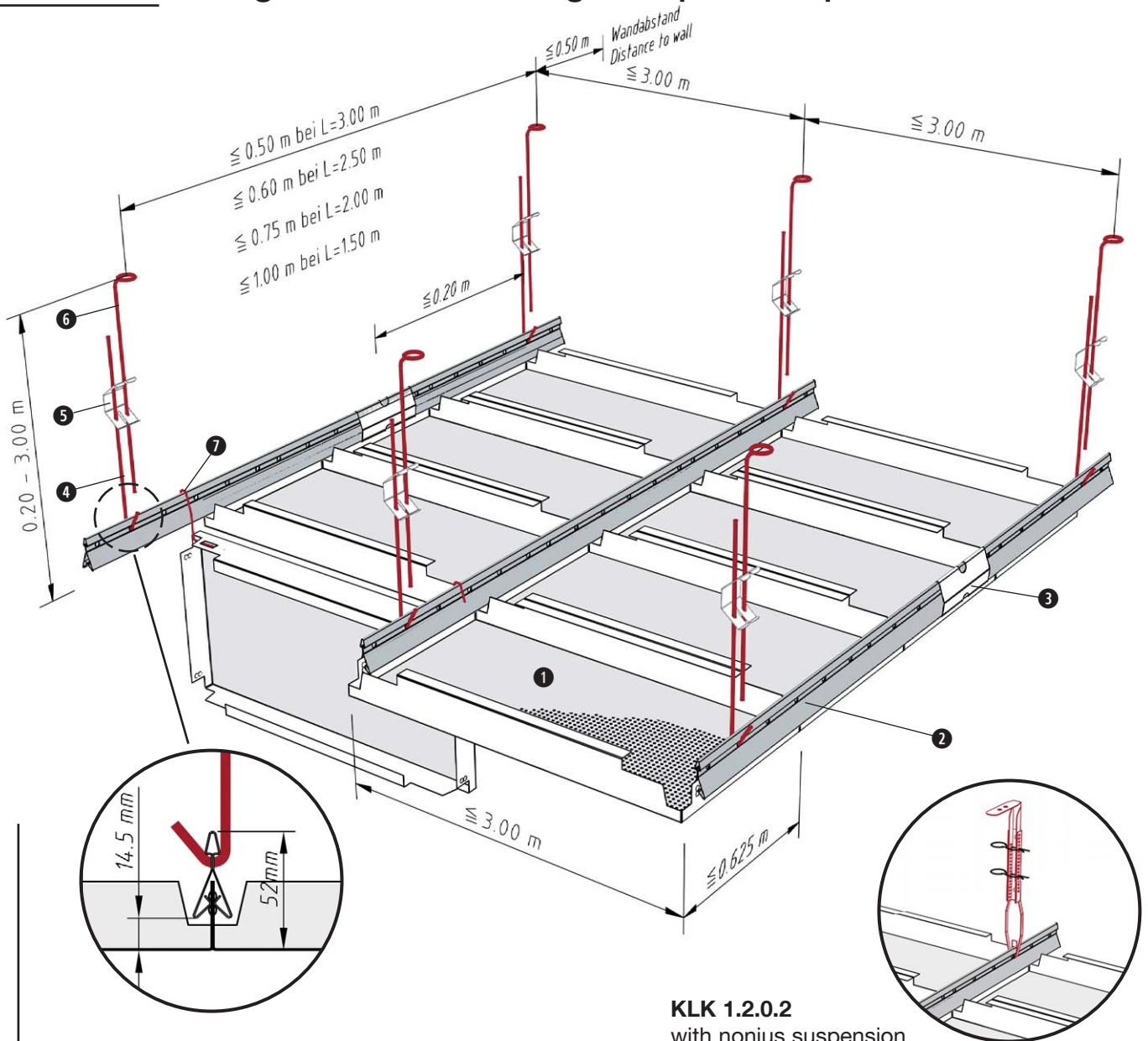

KLK 1.2.0.2
with nonius suspension

Quick installation. Elegant visual impression.

Standard components

required: KLK 1.2.0.1

Quantity / m²

Item	Designation	L=3.0m	L=2.5m	L=2.0m	L=1.5m	
1	Long span tile					
2	Clipping rail 16/38	0.33	0.40	0.50	0.67	metres
3	Main runner connector	0.08	0.10	0.13	0.17	units
4	Suspension wire with hook	0.67	0.67	0.67	0.67	units
5	Spring bracket	0.67	0.67	0.67	0.67	units
6	Suspension wire with loop	0.67	0.67	0.67	0.67	units
7	DOOR-wire bracket depending on tile format					

Installation

Distance between fixing points according to the sketch

Ceiling weight per m² alu app. 5 kg
 steel app. 8 kg

further instructions: p. 23 and p. 76-77

KLK 1.2.0.3

FURAL® Acoustic Ceilings Long span tiles – clip-in system

Standard design without double grid - minimum suspension height

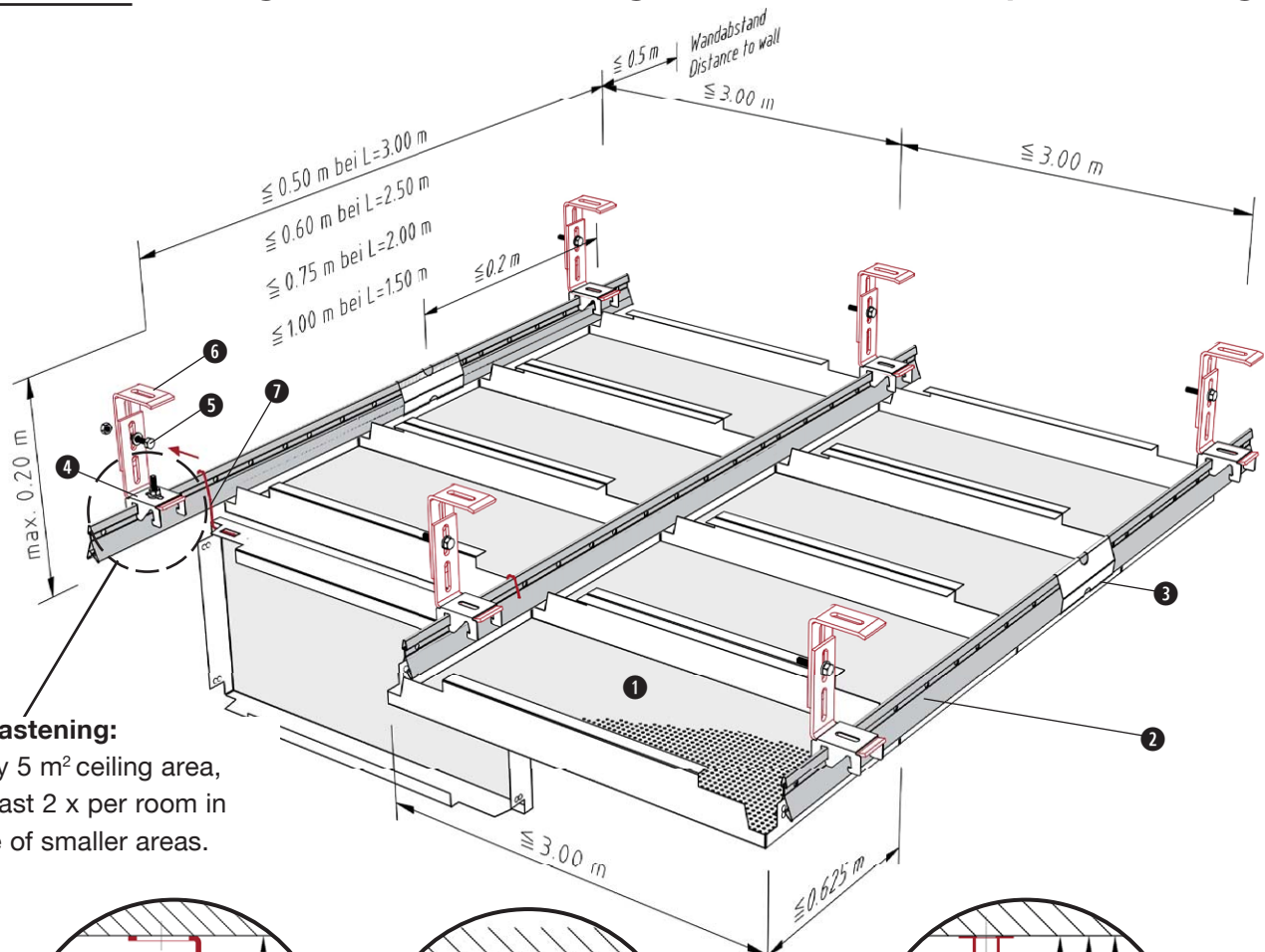

Screw fastening:

1 x every 5 m² ceiling area,
but at least 2 x per room in
the case of smaller areas.

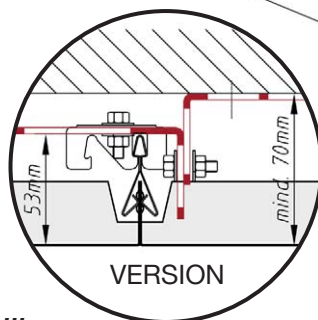
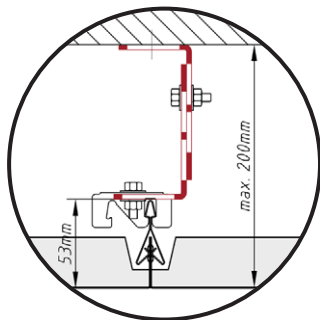

*Elegant long span tile ceiling
design with unbeatably low suspension height!*

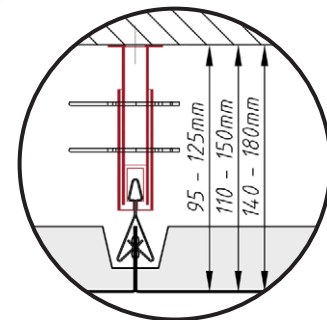

Version: with nonius short suspension

Standard components

required: KLK 1.2.0.3

Item	Designation	Quantity / m ²				
		L=3.0m	L=2.5m	L=2.0m	L=1.5m	
①	Long span tile					
②	Clipping rail 16/38	0.33	0.40	0.50	0.67	metres
③	Main runner connector	0.08	0.10	0.13	0.17	units
④	Fixing plate	0.67	0.67	0.67	0.67	units
⑤	Screw M6, complete	0.67	0.67	0.67	0.67	units
⑥	Universal fastening bracket	1.34	1.34	1.34	1.34	units
⑦	DOOR-wire bracket depending on tile format					

Installation

Distance between fixing points
according to the sketch

Ceiling weight per m² alu app. 5 kg
 steel app. 8 kg
further instructions: p. 23 and p. 76-77

KLK 1.2.1.1

FURAL® Acoustic Ceilings Long span tiles – clip-in system

Standard design with double grid - quick suspension element

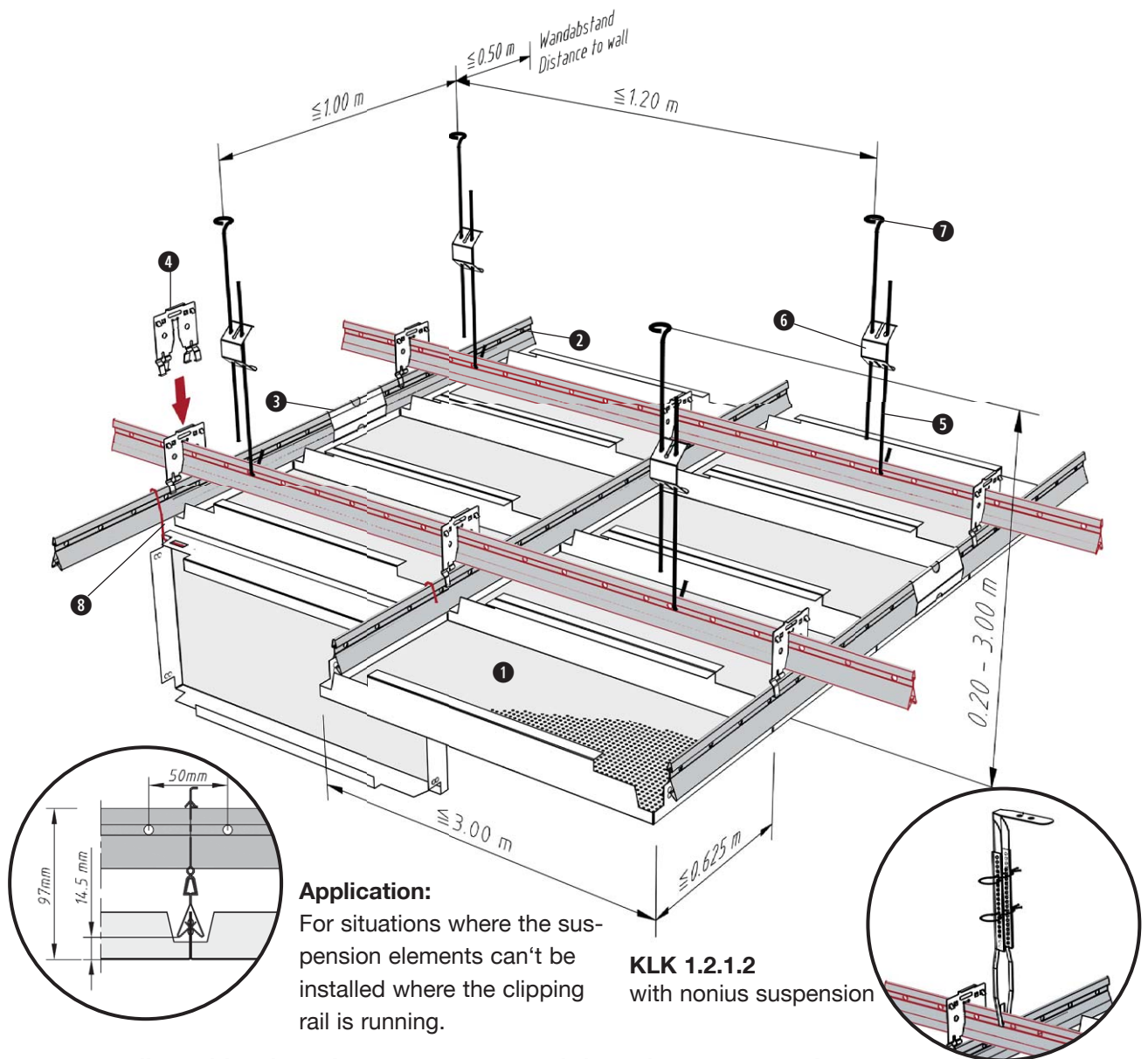

Application:

For situations where the suspension elements can't be installed where the clipping rail is running.

KLK 1.2.1.2
with nonius suspension

Long span tiles with a length of 3,000 mm and the advantages of the cross grid.

Standard components

required: KLK 1.2.1.1

Item	Designation	Quantity / m ²	L=1.5 m
①	Long span tile		
②	Clipping rail 16/38	1.67	metres
③	Main runner connector	0.42	units
④	Suspension key + security pin	0.67	units
⑤	Suspension wire with hook	0.83	units
⑥	Spring bracket	0.83	units
⑦	Suspension wire with loop	0.83	units
⑧	DOOR-wire bracket depending on tile formate		

Installation

Distance between fixing points according to the sketch

Ceiling weight per m² alu app. 5 kg
 steel app. 8 kg

further instructions: p. 23 and p. 76-77

KLK 1.2.2.3

FURAL® Acoustic Ceilings Long span tiles – clip-in system

Corridor ceiling „DOOR“ - hinged

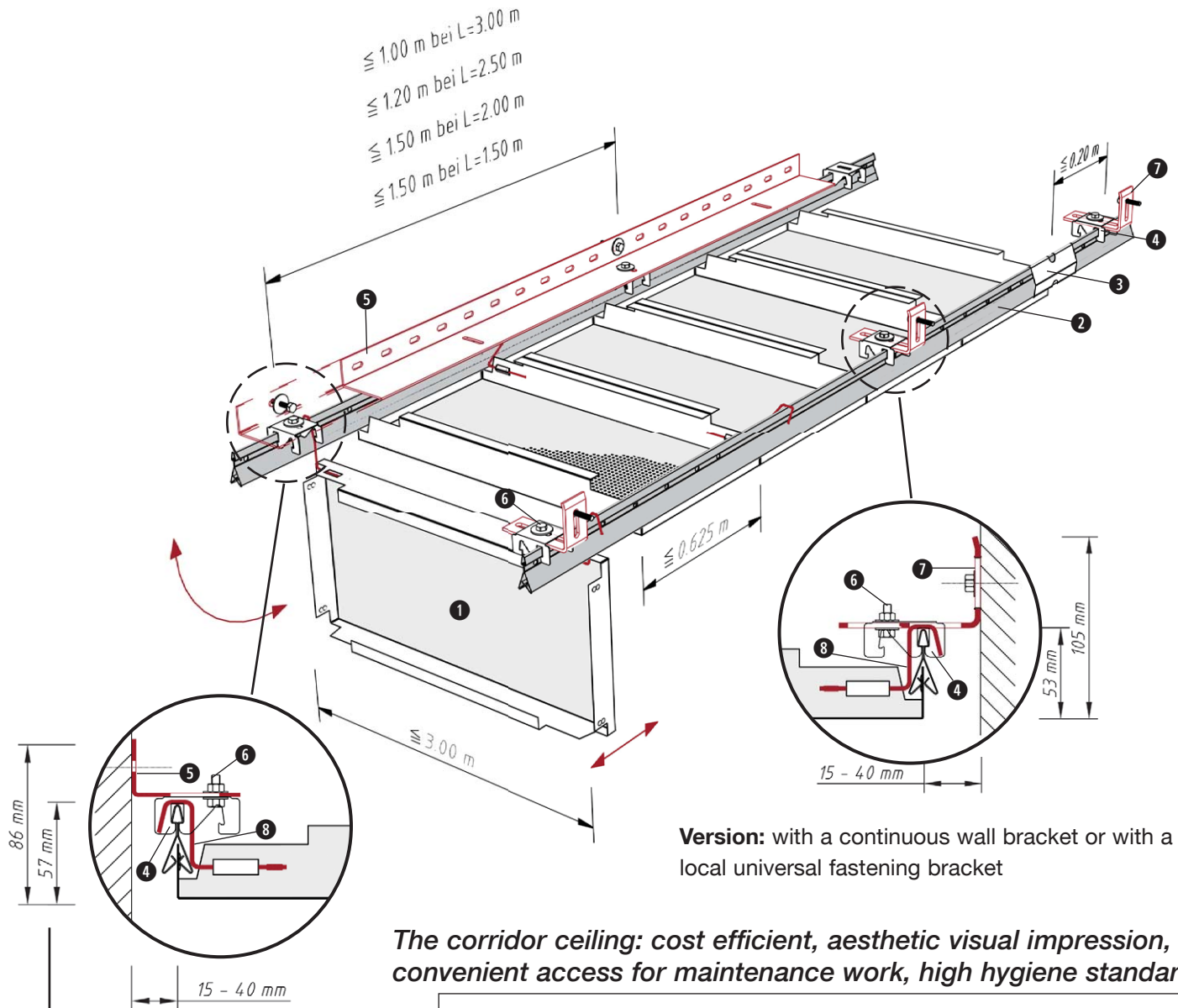

Installation

Distance between fixing points according to the sketch

Ceiling weight per m²:
 alu app. 5 kg
 steel app. 8 kg

further instructions: p. 23 and p. 76-77

Standard components

required: KLK 1.2.2.3

Item	Designation	Quantity / m ²			
		L=3.0m	L=2.5m	L=2.0m	L=1.5m
①	Long span tile				
②	Clipping rail 16/38	0.67	0.80	1.00	1.34 metres
③	Main runner connector	0.17	0.20	0.25	0.34 units
④	Fixing plate	0.67	0.67	0.67	0.89 units
⑤	Wall bracket 30/90	0.67	0.80	1.00	1.34 metres
⑥	Screw M6, complete	0.67	0.67	0.67	0.89 units
⑦	Universal fastening bracket	0.67	0.67	0.67	0.89 units
⑧	DOOR-wire bracket depending on tile format				

**KLK
1.2.3.4**

FURAL® Acoustic Ceilings
Long span tiles – clip-in system

Corridor ceiling „DOOR“ - hinged with closed shadow gap

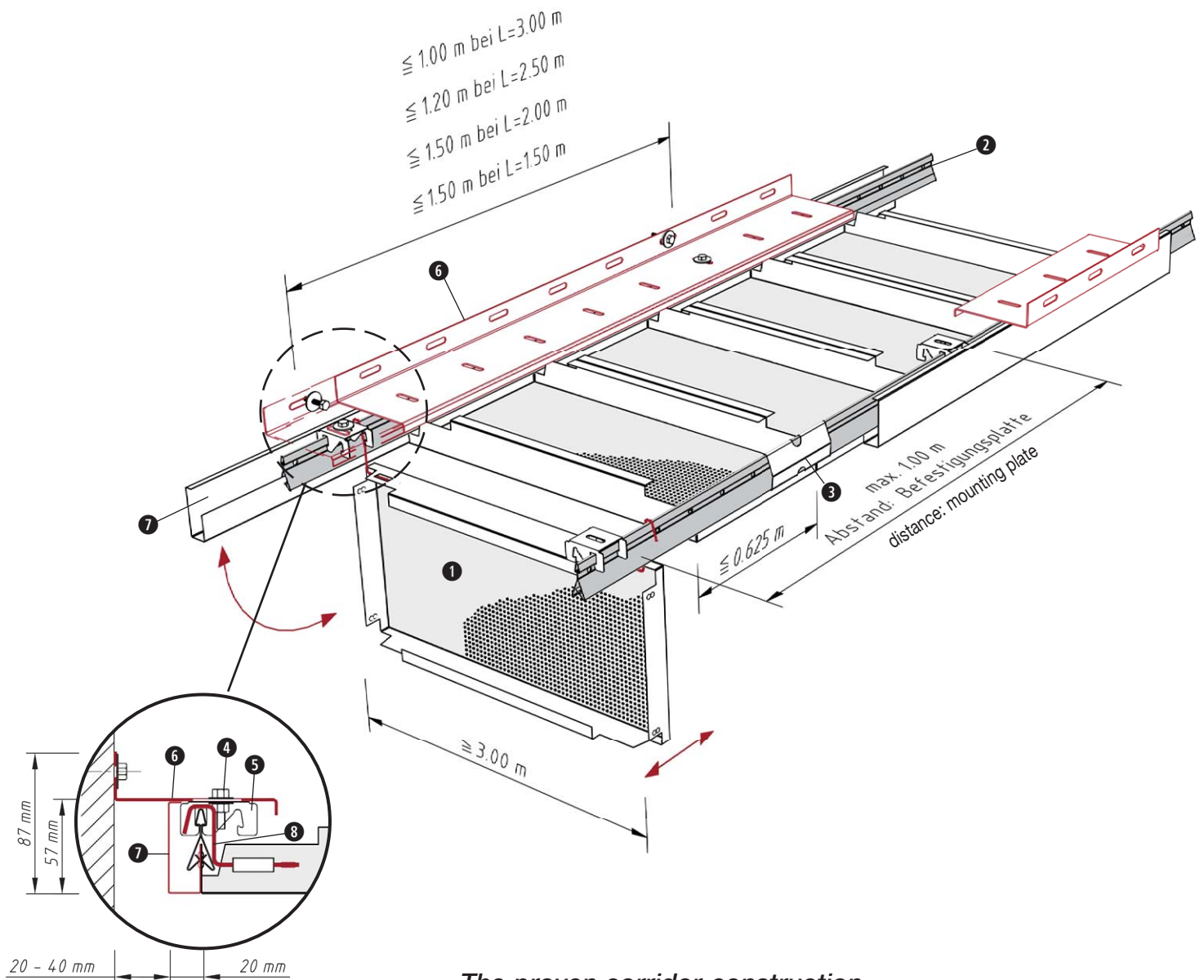

The proven corridor-construction.

Standard components

required: KLK 1.2.3.4 Corridor

Quantity / m²

Item	Designation	L=3.0 m	L=2.5 m	L=2.0 m	L=1.5 m	
①	Long span tile					
②	Clipping rail 16/38	0.67	0.80	1.00	1.34	metres
③	Main runner connector	0.17	0.20	0.25	0.34	units
④	Screw M6, complete	0.67	0.67	0.67	0.89	units
⑤	Fixing plate	0.67	0.67	0.67	0.89	units
⑥	Wall bracket for hospital	0.67	0.80	1.00	1.34	metres
⑦	Shadow section for hospital	0.67	0.80	1.00	1.34	metres
⑧	DOOR-wire bracket depending on tile format					

Installation

Distance between fixing points according to the sketch

Ceiling weight per m²: alu app. 5 kg
steel app. 8 kg

further instructions: p. 23 and p. 76-77



KLK 1.2.0.2 BWS

FURAL® Acoustic Ceilings Long span tiles – clip-in system

Ball-proof ceiling - with nonius suspension

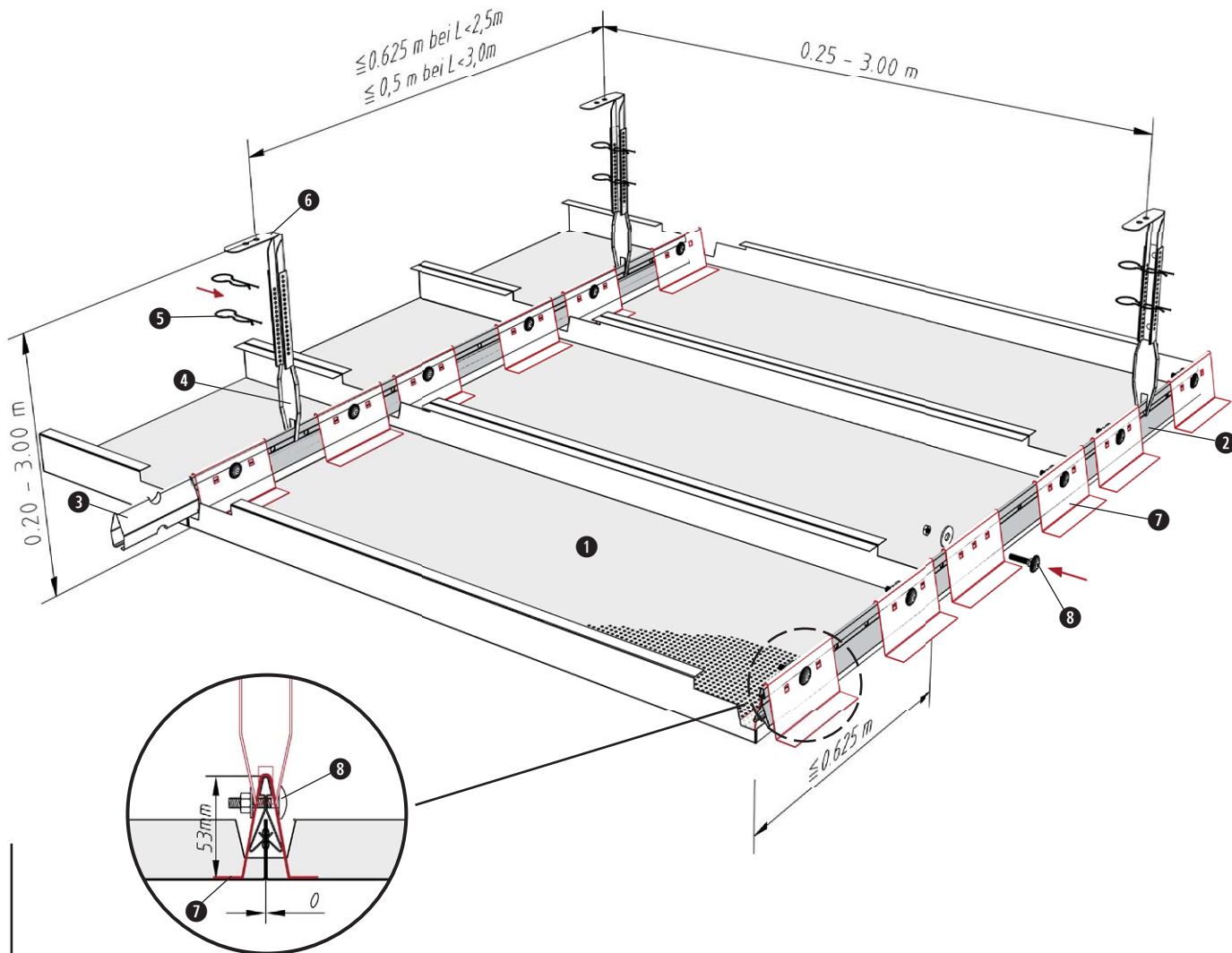

*Ball-proof design and maximum sound absorption.
Test certificate according to DIN 18032 Part 3 & EN
13964 attachment D.*

Standard components

required: KLK 1.2.0.2 BWS

At a tile width of 400 mm

Item Designation

Quantity / m²

Tile L=1.5 m Tile L=1.0 m

Item	Designation	Tile L=1.5 m	Tile L=1.0 m
①	Long span tile		
②	Clipping rail 16/38	0.67	1.00 metres
③	Main runner connector	0.16	0.25 units
④	Lower nonius	1.07	1.60 units
⑤	Securing pin	2.14	3.20 units
⑥	Upper nonius	1.07	1.60 units
⑦	Supporting bracket	3.34	5.00 units
⑧	Mushroom head bolt (square necked)	3.34	5.00 units

Installation

Distance between fixing points according to the sketch

Ceiling weight per m²: steel app. 8 kg

further instructions: p. 23 and p. 76-77

KLK 1.2.0.3 BWS

FURAL® Acoustic Ceilings Long span tiles – clip-in system

Ball-proof ceiling - short suspension

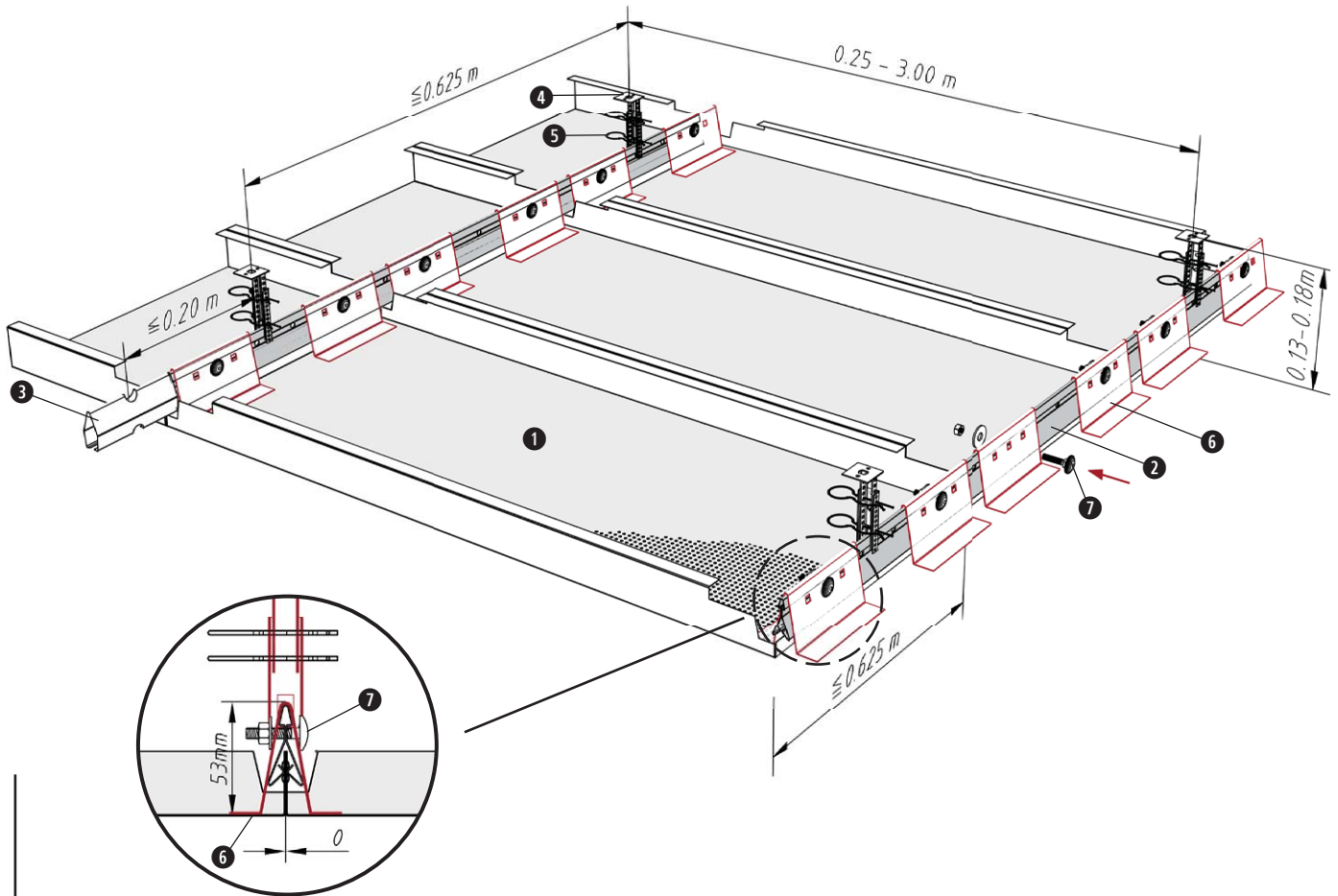

Ball-proof design even at minimum suspension height and maximum sound absorption. Test certificate according to DIN 18032 Part 3 & EN 13964 attachment D.

Standard components

required: KLK 1.2.0.3 BWS

At a tile width of 400 mm
Item Designation

Quantity / m²

Tile L=1.5m
Tile L=1.0m

Item	Designation	Quantity / m ²	Tile L=1.5m	Tile L=1.0m
①	Long span tile			
②	Clipping rail 16/38	0.67	1.00	metres
③	Main runner connector	0.16	0.25	units
④	Upper and lower nonius (set)	1.07	1.60	units
⑤	Securing pin	2.14	3.20	units
⑥	Supporting bracket	3.34	5.00	units
⑦	Mushroom head bolt (square necked)	3.34	5.00	units

Installation

Distance between fixing points according to the sketch

Ceiling weight per m² steel app. 8 kg

further instructions: p. 23 and p. 76-77

for clip-in system

KQK

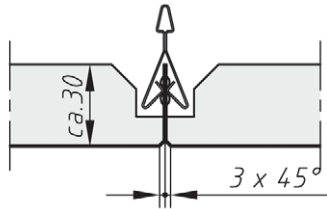

with bevelled edges

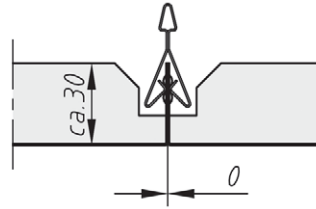

sharp edged

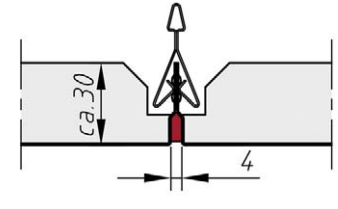

with crimp

KLK

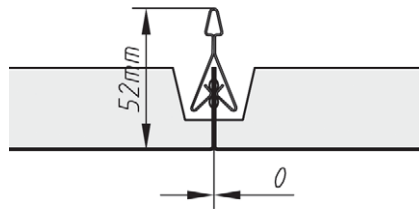

KLK sharp edged

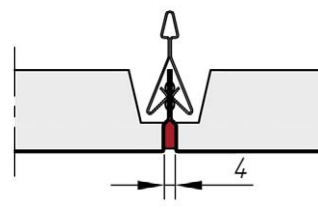

KLK with crimp

Longitudinal webs

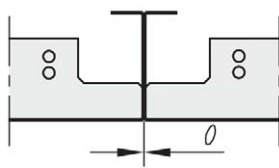

without gap

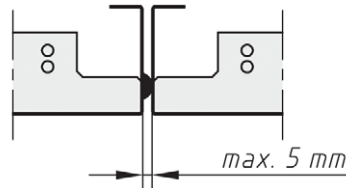

distance embossing

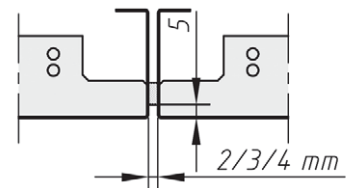

sealing tape

Edge

Connection plasterboard

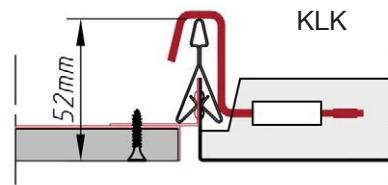
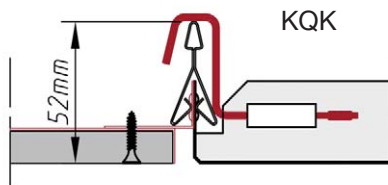

joint as desired



Further wall connections
see page 69

Details

FURAL® Acoustic Ceilings Edges and webs

for clip-in system

Standard long span tiles:

Length and width variabel

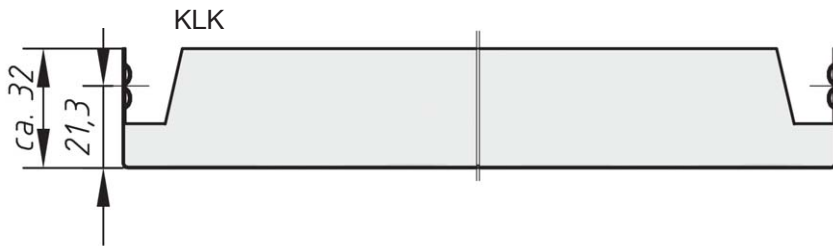
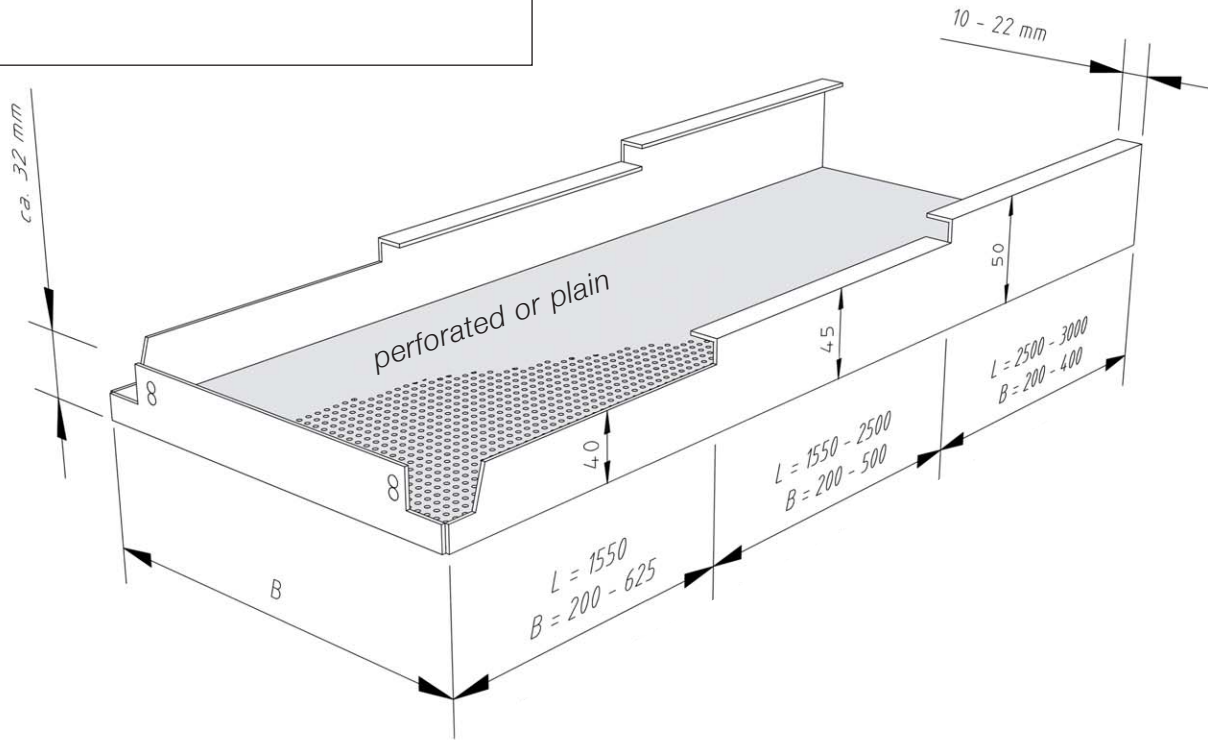

STANDARD
BB sharp edged

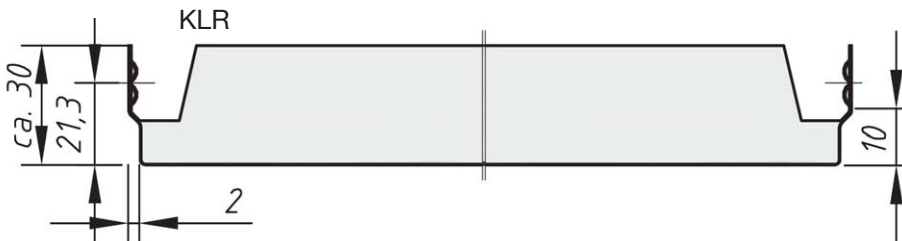

BB with crimp
(for hygiene ceiling)

Longitudinal webs

Cross webs



for clip-in system – square tiles

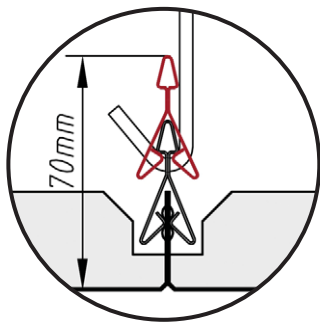
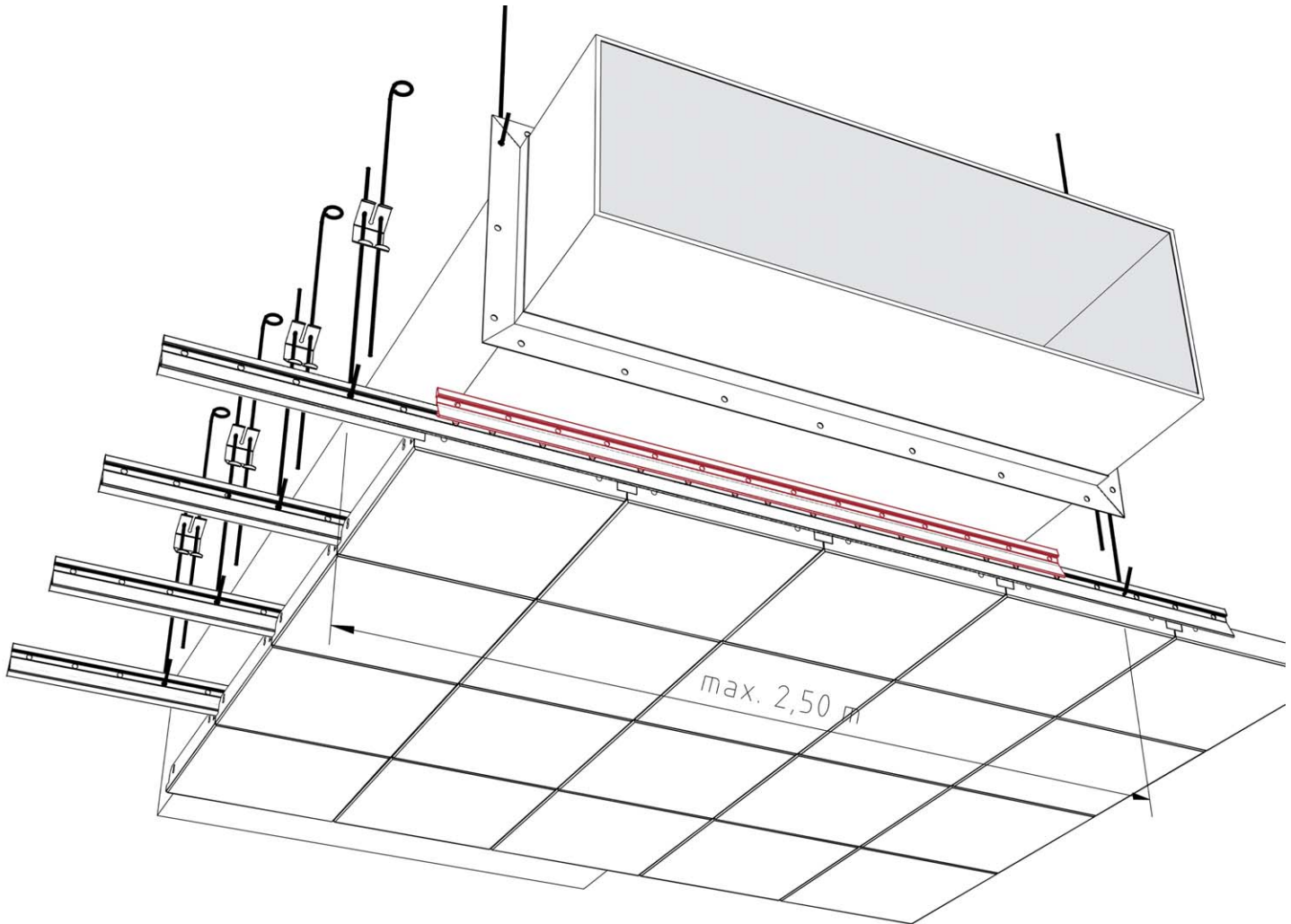

Wide-span girders

for bridging installations
(e.g. ventilation or cable ducts)

Maximum distance between suspension
elements: 2.50 m

Clip 2 clipping rails one above the other.

Suspension element installation

- quick suspension element
- nonius hanger
- universal mounting bracket

Fastener spacing:

- According to respective system description (page 6 -22)

Fastening materials:

- Use only fasteners suitable for the type of substrate and, where appropriate, with the necessary building authority approval

Tools:

- Hammer drill (solid concrete), power drill
- Depending on rawl plug and bolt types, hammer and/or spanners

Installation procedure:

- Check whether any inbuilt parts (such as ventilation ducts, etc.) are installed too low in the ceiling cavity – if so, discuss with site manager
- First mark suspension element position on the raw ceiling with a chalk line or laser and tape measure
- Drill hole and insert rawl plug, fasten suspension element with bolt in rawl plug
- Adjust suspension elements roughly to the required height

Clipping rail installation

- Install single-rail grid or double-rail grid, depending on ceiling system, normally with the clipping rail in a longitudinal direction to the lower clipping rail layer always parallel to the room's long side (with strip lighting also always parallel to the strip light's long side)
- With a double-rail grid, first place the cross-connectors onto the upper clipping rails and press in the lower clipping rail; always taking care to press in the securing pin.
- Pay attention to a clean cut at the end of the clipping rail; if the cut is not clean and the clipping rail sides open, insert an M6 x 20 mm bolt with 2 large washers (Ø 25 – 30 mm) into a dividing hole at the end of the rail. Tighten the nut by hand only until the two radii of the sides contact one another. This is necessary to achieve a sufficient retaining force of the clipping rails
- Use the clipping rail coupler for clipping rail butt joints
- Adapt the rails roughly to the later tile junction

- Now adjust the suspension elements precisely to the ceiling height

Tile Installation

- Unpack and install the tiles - always wear ceiling installer gloves when working in order to avoid soiling
- Always install the first complete row of tiles on the longer side of the room and check whether the tile edges are in a line and run parallel to the wall. Mark the exact tile edge with a line tied from wall to wall or with a rotating laser, ensuring that the tiles do not interlock at the corners – install precisely corner to corner
- Install the cut tiles in the open space remaining between the wall and the first complete row of tiles, and then install the next complete row of tiles, etc.
- For the cut tiles, measure the distance from the edge of the tile to the front edge of the edge profile and add + 15 mm for the support - this is the cutting dimension
- Cut the tile to size using an electric nibbler or sheet metal shears
- Push in the cut tile at a slight angle from below between the upper edge of the edge bracket and the lower edge of the trimming, turn the front edge of the cut tile also to a slight angle relative to the front edge of the edge bracket to allow the tile to be pressed in more easily, then press the tile web into the clipping rail
- In the corner of the room, always install the corner tile with two cut sides first, then the cut tile alongside the corner tile

Tile removal

- See ceiling manual, page 118
- Always pull off the tiles at the clipping rail web in the corner of the tile

Information:

For variants of the different ceiling systems, see system descriptions in the ceiling manual. Please also note the information regarding the requirements of EN 13964 relating to the CE standard marking on pages 76 – 77.





HANG-IN SYSTEM

ADVANTAGES :

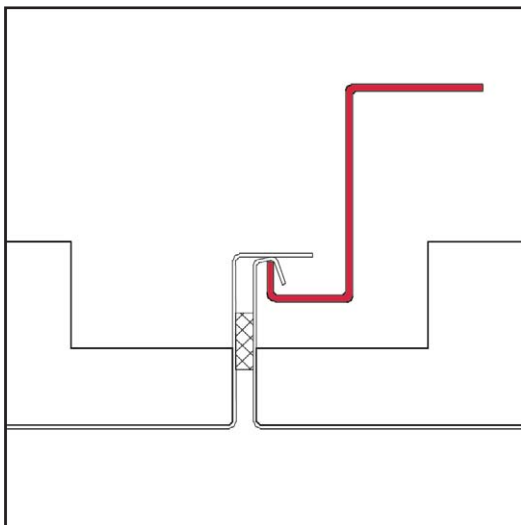

› Maximum safety:

- Continuous hang-in edges guarantee the perfect fit of the support structure.

› Convenient installation:

- FURAL Z-rail continuously adjustable on the grid rail
- No tools required for dismantling

› Visual advantages:

- The freely floating ceiling solution without enclosing section
- Free choice of wall connections

Format:	Grid:	Suspension:	Function:	Code:	Page:
Square	with grid	nonius suspension		KQH - 2.1.1.2	26
Square	with grid	short suspension		KQH - 2.1.1.3	27
Long span	with grid	nonius suspension	room	KLH - 2.2.1.2	28
Long span	with grid	short suspension	room	KLH - 2.2.1.3	29
Long span	wall mounting	bracket	corridor	KLK - 2.2.2.3	30
Joints/Edges/Webs					31
Installation					33
Long span	with grid and H-profile	threaded rod		KLH-H28	34
Wall connection					69
Further information on the requirements of EN 13964 according to CE-mark					76 - 77

KQH 2.1.1.2

FURAL® Acoustic Ceilings Square tiles – hang-in system

Standard design with double grid - nonius suspension

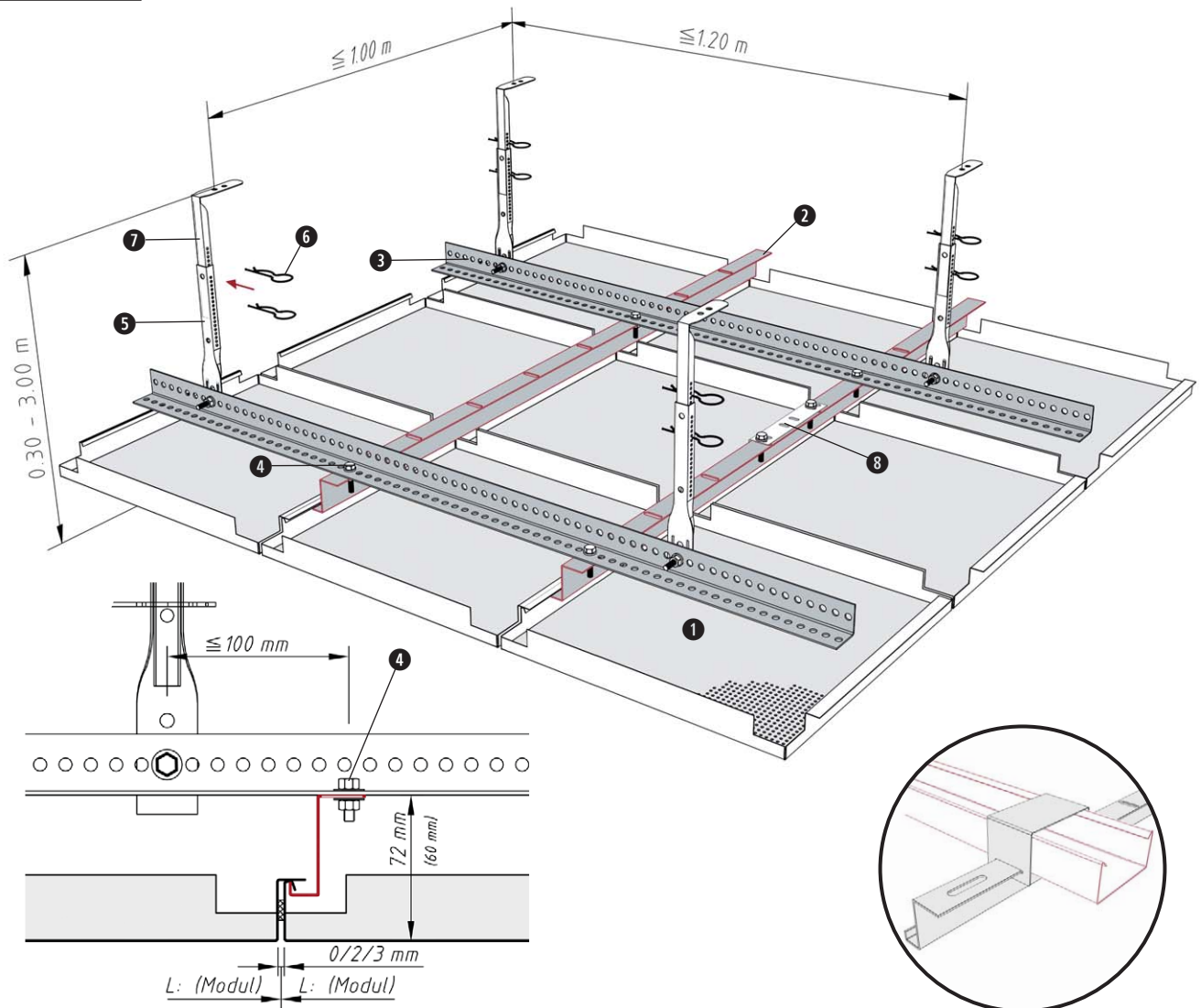

All height specifications refer to the Z-hang-in-rail, height 50 mm.

Version: with CD-profile and alternative Z-hang-in-rail

*Stress-free quick installation -
clean visual impression*

Standard components

required: KQH 2.1.1.2

Item	Designation	Quantity / m ²		
		625	600	
①	Hang-in tile	2.56	2.78	units
②	Z-hang-in-rail 50 (38)	1.60	1.67	metres
③	Grid bracket 30/30	1.00	1.00	metres
④	Hexagon screw M6	3.71	3.83	units
⑤	Lower nonius	0.83	0.83	units
⑥	Securing pin	1.66	1.66	units
⑦	Upper nonius	0.83	0.83	units
⑧	Main runner connector for Z-hang-in-rail	*	*	units

* depends on Z-hang-in-rail used

Installation

Distance between fixing points according to the sketch
Ceiling weight per m² steel app. 8 kg
further instructions: p. 33 and p. 76-77

KQH 2.1.1.3

FURAL® Acoustic Ceilings Square tiles – hang-in system

Standard design with double grid - short suspension

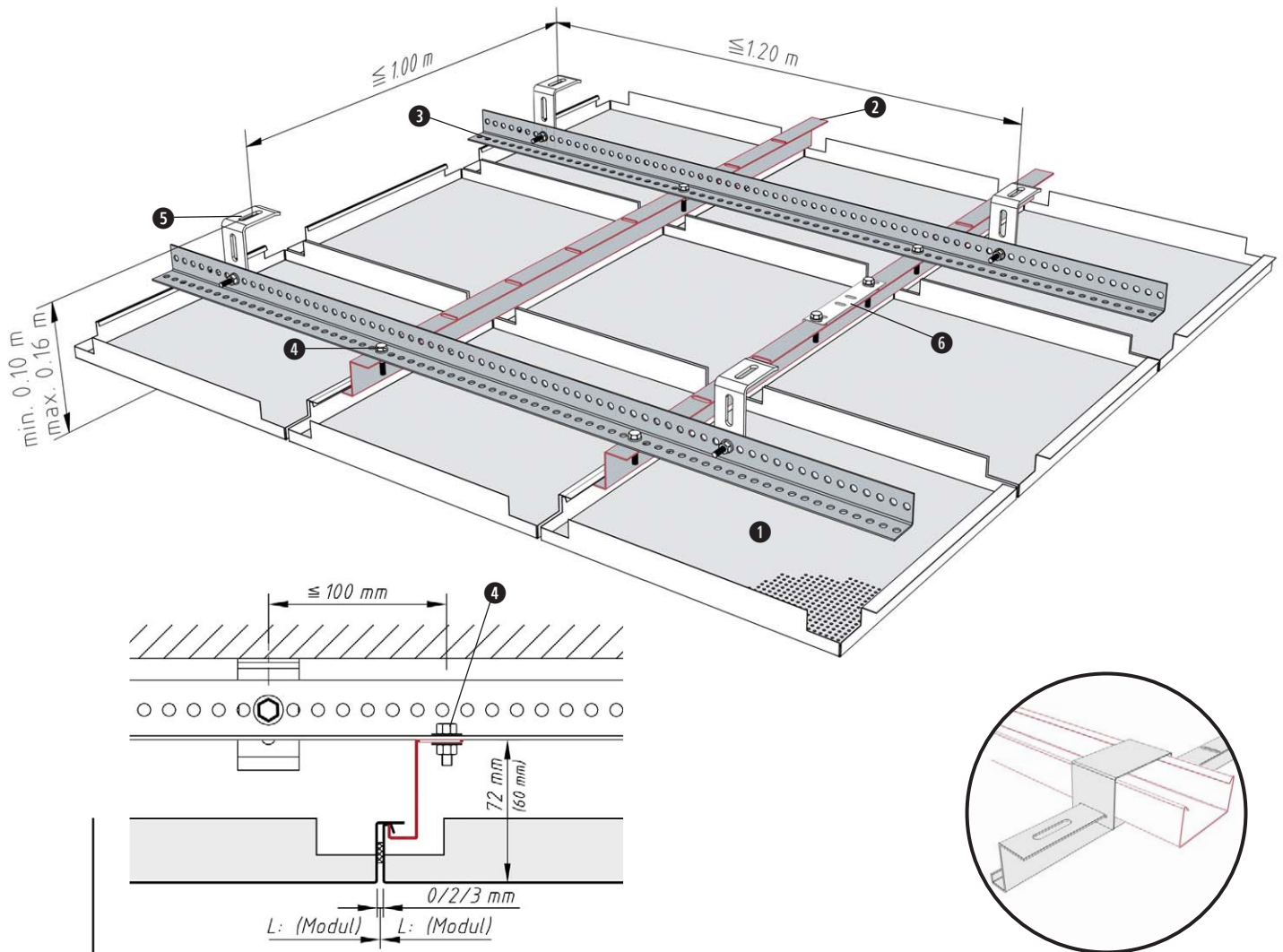

All height specifications refer to the Z-hang-in-rail, height 50 mm.

Version: with CD-profile and alternative Z-hang-in-rail

The solution for short suspension.

FURAL

Standard components

required: KQH 2.1.1.3

Item	Designation	Quantity / m ²		
		625	600	
①	Hang-in tile	2.56	2.78	units
②	Z-hang-in-rail 50 (38)	1.60	1.67	metres
③	Grid bracket 30/30	1.00	1.00	metres
④	Hexagon screw M6	3.71	3.83	units
⑤	Universal fastening bracket	0.83	0.83	units
⑥	Main runner connector for Z-hang-in-rail	*	*	units

* depends on Z-hang-in-rail used

Installation

Distance between fixing points according to the sketch
 Ceiling weight per m² steel app. 8 kg
 further instructions: p. 33 and p. 76-77

KLH 2.2.1.2

FURAL® Acoustic Ceilings Long span tiles – hang-in system

Standard design with double grid - nonius suspension

All height specifications refer to the Z-hang-in-rail, height 50 mm.

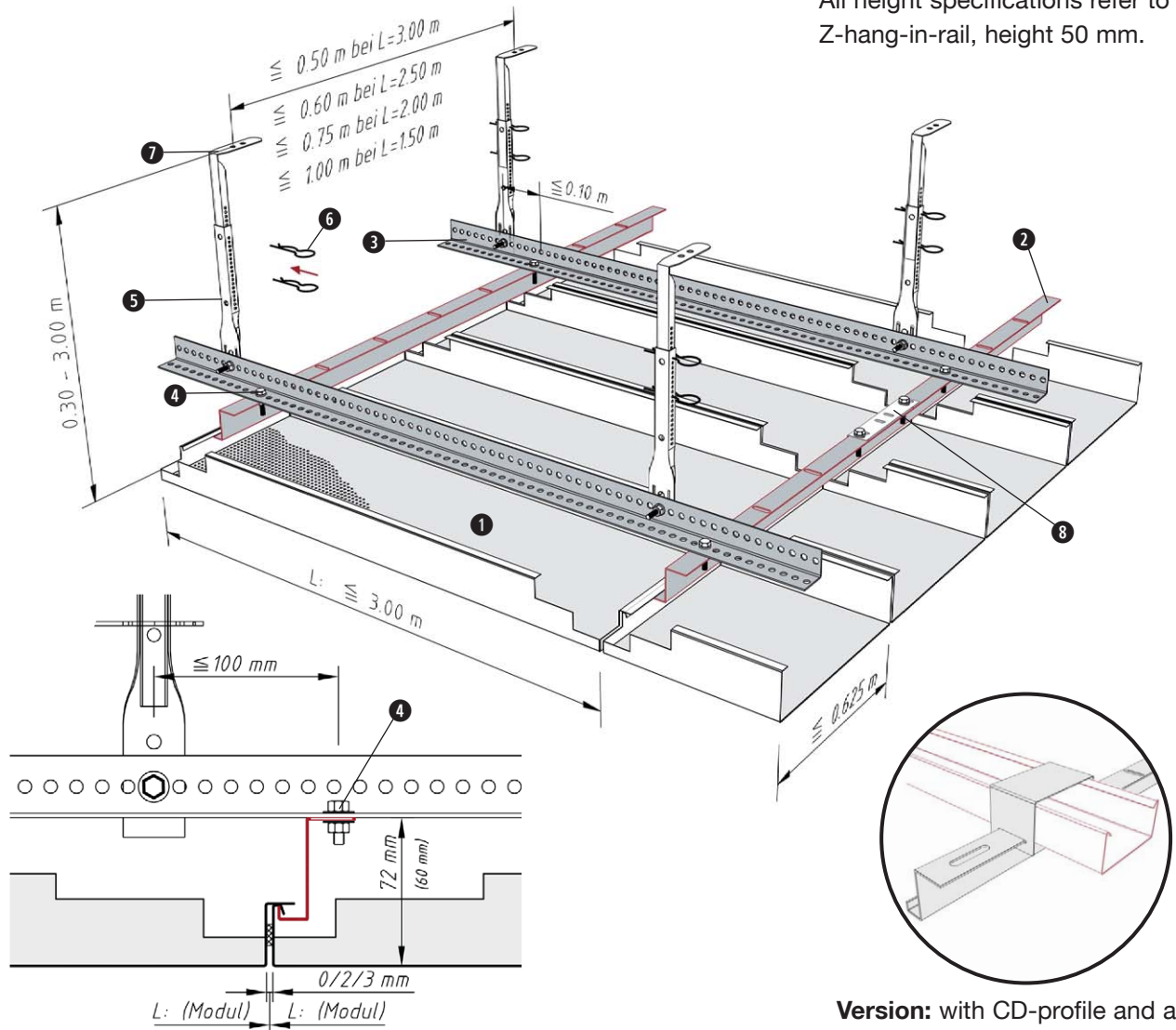

Version: with CD-profile and alternative Z-hang-in-rail

Clean visual impression and ease of installation thanks to variable adjustment of the support structure.

Installation

Distance between fixing points according to the sketch
Ceiling weight per m²: steel app. 8 kg
further instructions: p. 33 and p. 76-77

Standard components

required: KLH 2.2.1.2

Item	Designation	Quantity / m ²				
		L=3.0 m	L=2.5 m	L=2.0 m	L=1.5 m	
①	Hang-in tile					
②	Z-hang-in-rail 50 (38)	0.33	0.40	0.50	0.67	metres
③	Grid bracket 30/30	2.00	1.67	1.33	1.00	metres
④	Hexagon screw M6	1.60	1.66	1.74	1.88	units
⑤	Lower nonius	0.67	0.67	0.67	0.67	units
⑥	Securing pin	1.34	1.34	1.34	1.34	units
⑦	Upper nonius	0.67	0.67	0.67	0.67	units
⑧	Main runner connector for Z-hang-in-rail	0.13	0.16	0.20	0.27	units

KLH 2.2.1.3

FURAL® Acoustic Ceilings Long span tiles – hang-in system

Standard design with double grid - with short suspension

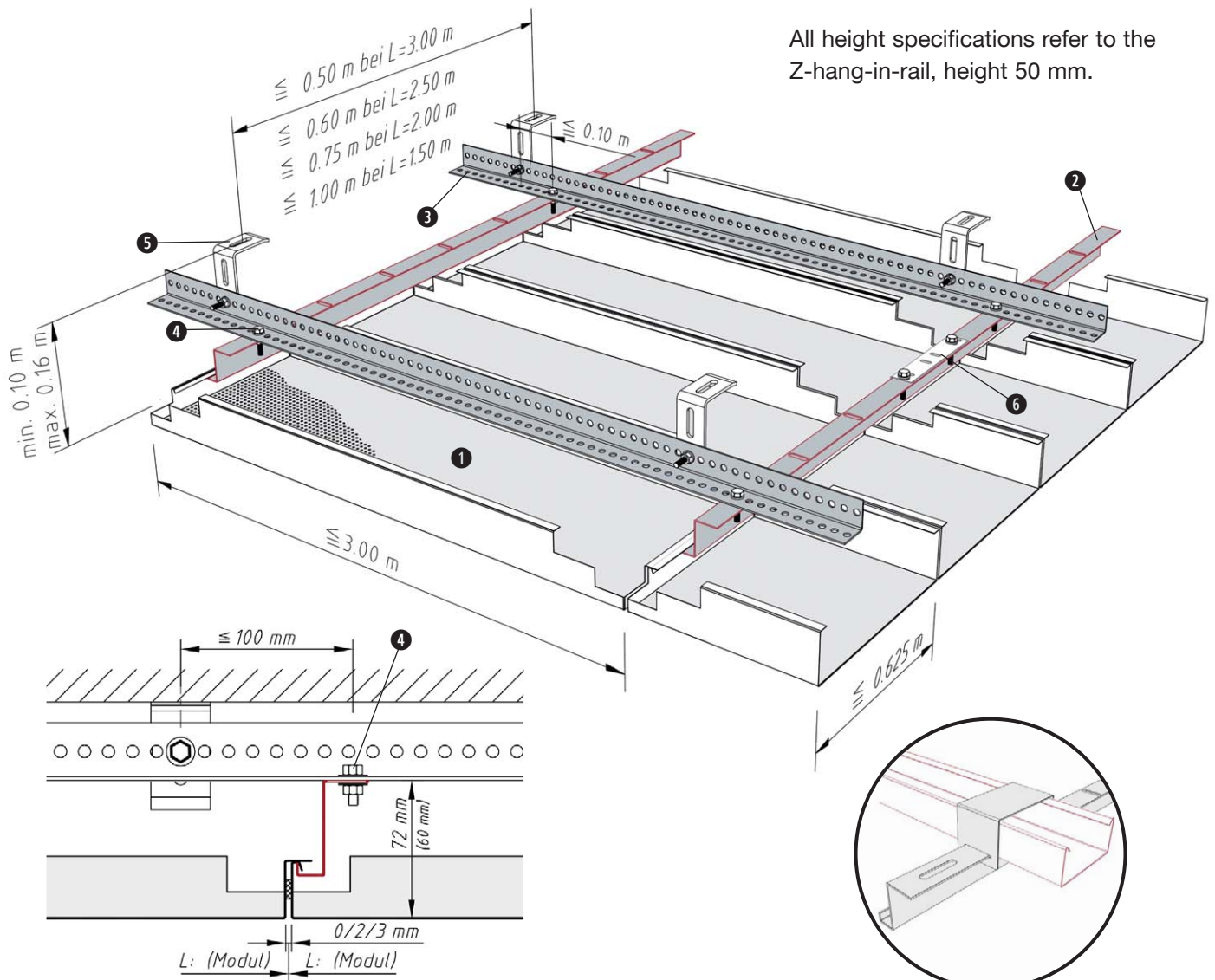

All height specifications refer to the Z-hang-in-rail, height 50 mm.

Version: with CD-profile and alternative Z-hang-in-rail

The advantages of the hang-in system even at minimum suspension height.

Installation

Distance between fixing points according to the sketch
Ceiling weight per m² steel app. 8 kg
further instructions: p. 33 and p. 76-77

Standard components required: KLH 2.2.1.3

Item	Designation	Quantity / m ²				
		L=3.0 m	L=2.5 m	L=2.0 m	L=1.5 m	
①	Hang-in tile					
②	Z-hang-in-rail 50 (38)	0.33	0.40	0.50	0.67	metres
③	Grid bracket 30/30	2.00	1.67	1.33	1.00	metres
④	Hexagon screw M6	1.60	1.66	1.74	1.88	units
⑤	Universal fastening bracket	0.67	0.67	0.67	0.67	units
⑥	Main runner connector for Z-hang-in-rail	0.13	0.16	0.20	0.27	units

KLG 2.2.2.3

FURAL® Acoustic Ceilings Long span tiles – hang-in system

Standard design corridor ceiling

All height specifications refer to the Z-hang-in-rail height 38 mm.

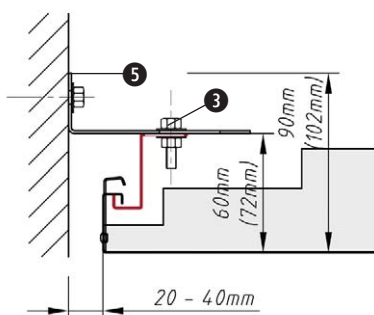
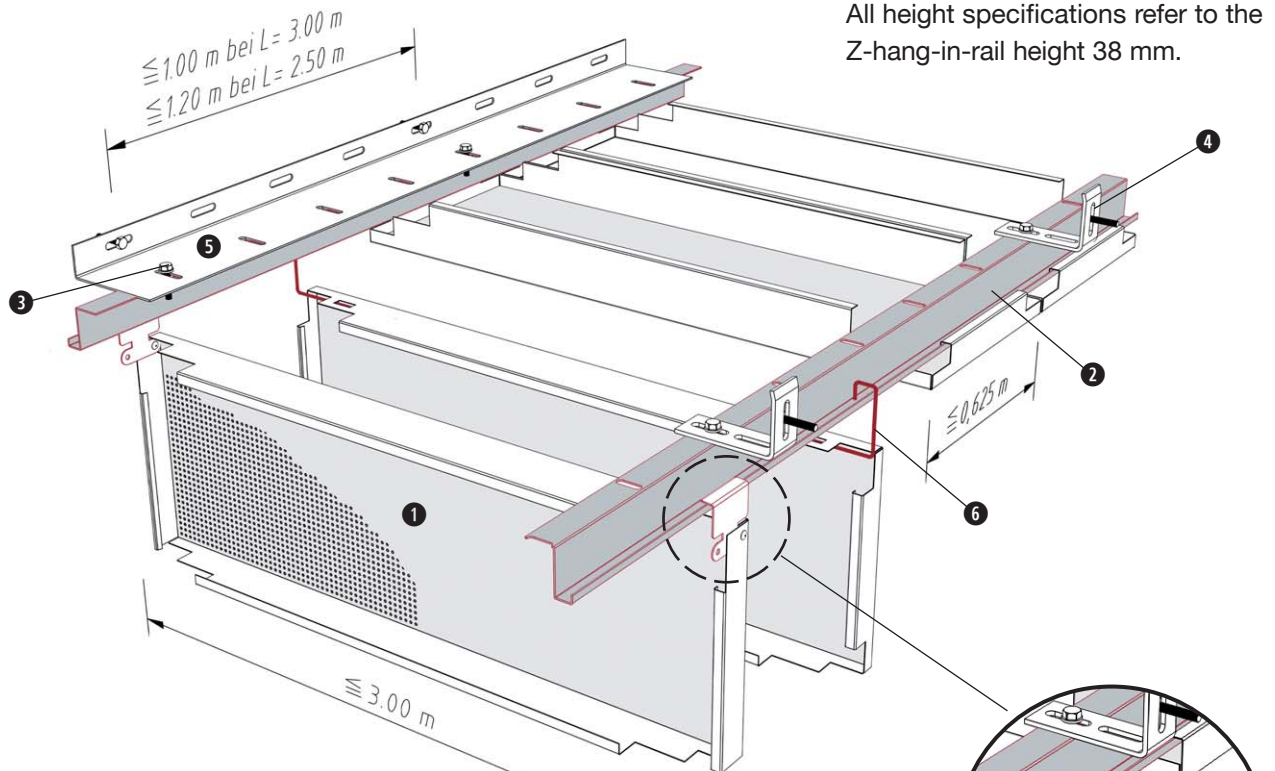

Wall mounting type A:
with continuous wall bracket

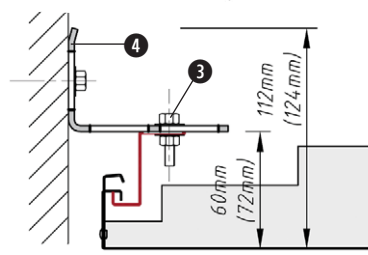

Wall mounting type B:
with local universal fastening
bracket

Option for hinge down:
with DOOR-bracket

*Accuracy, hygiene and
a high degree of safety!*

Installation

Distance between fixing points
according to the sketch
Ceiling weight per m²
steel app. 8 kg
further instructions:
p. 33 and p. 76-77

Standard components required: KLG 2.2.2.3

Item	Designation	Quantity / m ²				
		L=3.0 m	L=2.5 m	L=2.0 m	L=1.5 m	
①	Hang-in tile					
②	Z-hang-in-rail 50 (38)	0.67	0.80	1.00	1.34	metres
③	Hexagon screw M6					
④	Universal fastening bracket	0.67	0.67	0.82	1.02	units
⑤	Wall bracket 30/90	0.67	0.80	1.00	1.34	metres
⑥	DOOR-wire bracket					

for hang-in system with Z-hang-in-rail

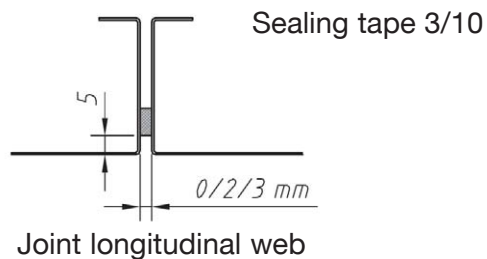
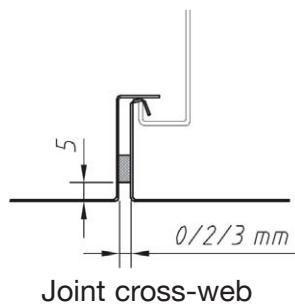
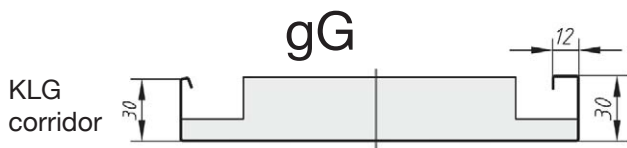
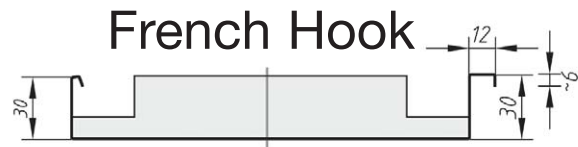
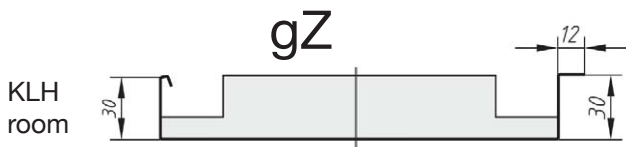
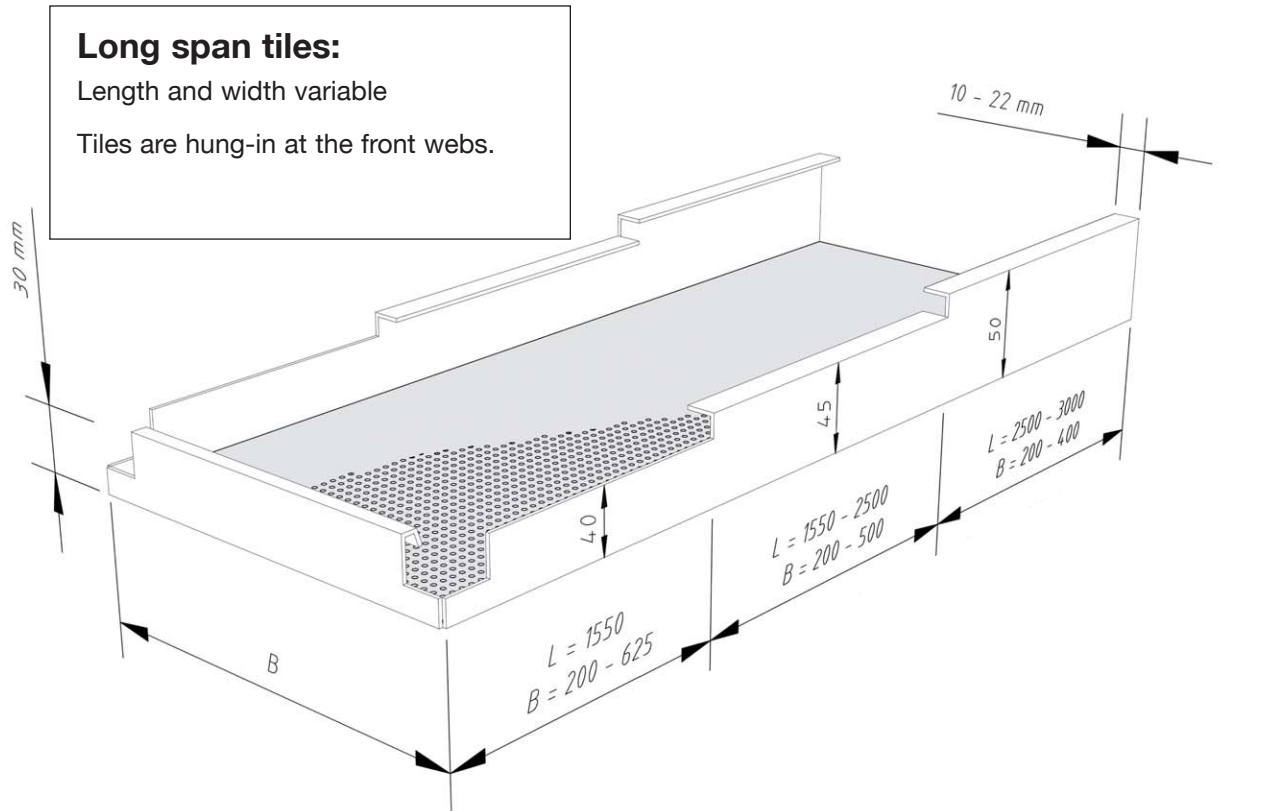

Longitudinal webs

Cross webs

Joints





Suspension element installation

- Nonius hanger
- Universal mounting bracket

Fastener spacing:

- According to respective system description (page 26 – 31)

Fastening materials:

- Use only fasteners suitable for the type of substrate and, where appropriate, with the necessary building authority approval

Tools:

- Hammer drill (solid concrete), power drill
- Depending on rawl plug and bolt types, hammer and/or spanners

Installation procedure:

- Check whether any inbuilt parts (such as ventilation ducts, etc.) are installed too low in the ceiling cavity – if so, discuss with site manager
- First mark suspension element position on the raw ceiling with a chalk line or laser and tape measure
- Drill hole and insert rawl plug, fasten suspension element with bolt in rawl plug
- Adjust suspension elements roughly to the required height

Installation of Z-hang-in-rail and transverse structure

- Install upper grid profile (grid angle 30/30/2 mm or CD profile)
- Connect Z-shaped profile to upper grid profile (with M6 bolt). For grid angle, use FURAL Z-hang-in-rail H 50 mm with slots at the top (commercially available rails do not provide adequate adjustment options!)
- For CD profile, commercially available Z-hang-in-rail can be used with special retaining bracket (this allows the Z-shaped profile to be steplessly positioned on the CD profile)
- **FURAL** recommends 50 mm high Z-hang-in-rails, as the tiles in the middle of the section are then easier to remove.
- Normally in rooms, always install the Z-hang-in-rails parallel to the room long side
- Now adjust the suspension elements precisely to the ceiling height

Tile installation

- Unpack and install the tiles - always wear ceiling

installer gloves when working in order to avoid soiling

- Always install the first complete row of tiles on the longer side of the room and check whether the tile edges are in a line and run parallel to the wall. Mark the exact tile edge with a line tied from wall to wall or with a rotating laser, ensuring that the tiles do not interlock at the corners – install precisely corner to corner
- Install the cut tiles in the open space remaining between the wall and the first complete row of tiles, and then install the next complete row of tiles, etc.
- For the cut tiles, measure the distance from the edge of the tile to the front edge of the edge profile and add + 15 mm for the support - this is the cutting dimension
- Cut the tile to size using an electric nibbler or sheet metal shears
- Push in the cut tile at a slight angle from below between the upper edge of the edge bracket and the lower edge of the trimming, turn the front edge of the cut tile also to a slight angle relative to the front edge of the edge bracket to allow the tile to be pressed in more easily, then press the tile web into the Z-hang-in-rail
- In the corner of the room, always install the corner tile with two cut sides first, then the cut tile alongside the corner tile
- With an open joint to the wall, the first row of tiles can be installed directly at the wall – pay attention to the perpendicularity of the tile long side relative to the wall
- Always ensure the same bending direction of the end tabs (do not mix)

Tile removal

- For tiles in the hall area, simply lift them out without using tools
- For tiles in rooms, lift up the front end of the tile with rectangular edge-fold by approx. 40 mm and lift the tile with the hook edge-fold by approx. 10 mm then pull the tile in longitudinal direction away from the Z-shaped profile

Information

For variants of the different ceiling systems, see system descriptions in the ceiling manual. Please also note the information regarding the requirements of EN 13964 relating to the CE standard marking on pages 76 – 77.

KLH-H28 4.2.1.5

FURAL® Acoustic Ceilings Long span tiles – H-hang-in system

Standard design with H-profile

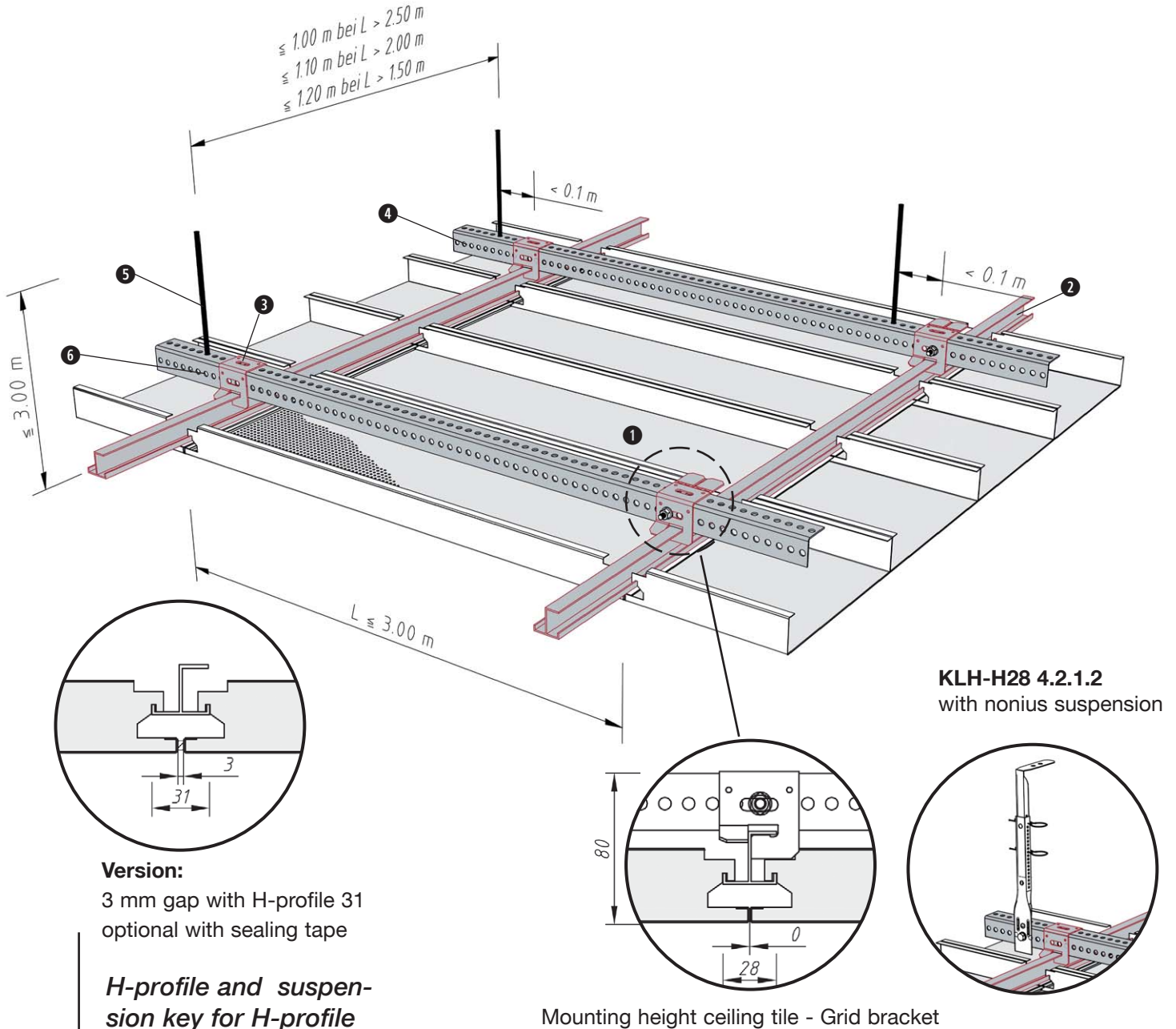

Version:

3 mm gap with H-profile 31
optional with sealing tape

H-profile and suspension key for H-profile ensure precise joint pattern.

KLH-H28 4.2.1.2
with nonius suspension

Mounting height ceiling tile - Grid bracket

Installation

Distance between fixing points according to the sketch
Ceiling weight per m² steel app. 8 kg or 5 kg alu
further instructions: p. 33 and p. 76-77

Standard components

required: KLH-H28

Item	Designation	Quantity / m ²				
		L=3,0 m	L=2,5 m	L=2,0 m	L=1,5 m	
①	Hang-in tile					
②	H-profile 28 (31)	0.33	0.40	0.50	0.67	metres
③	Suspension key for H-profile	0.33	0.40	0.45	0.56	units
④	Grid bracket 30/30	1.00	1.00	0.91	0.83	metres
⑤	Threaded rod M6	0.33	0.40	0.45	0.56	units
⑥	Nut + washer M6	0.33	0.40	0.45	0.56	units

KLH-H28 4.2.1.5

FURAL® Acoustic Ceilings Long span tiles – H-hang-in system

Installation

Slide in the suspension key in H-profile

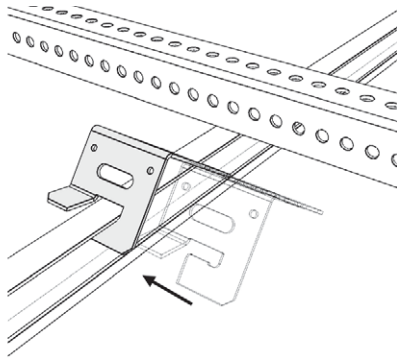

Move the suspension key toward the grid bracket.

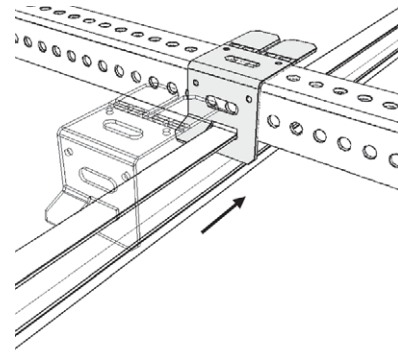

Safeguard is done manually by turning down the locking tab!

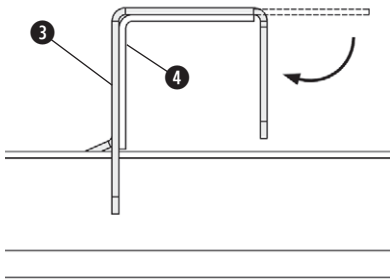

Additional: Safeguard is done by screwing 1x per H-profile.

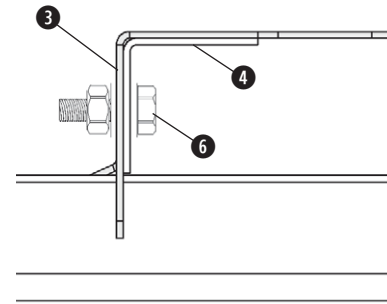

Wall connections

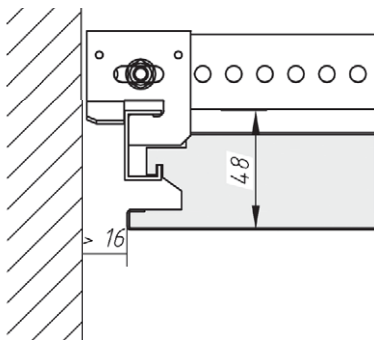

With C-profile for shadow gap

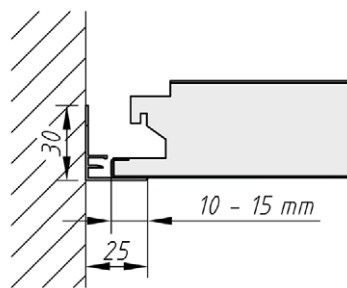

With trimming section for entire tile

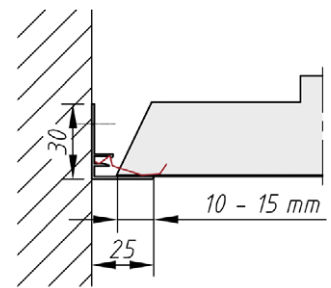

Support with trimming section for cut tile







LAY-IN SYSTEM

ADVANTAGES :

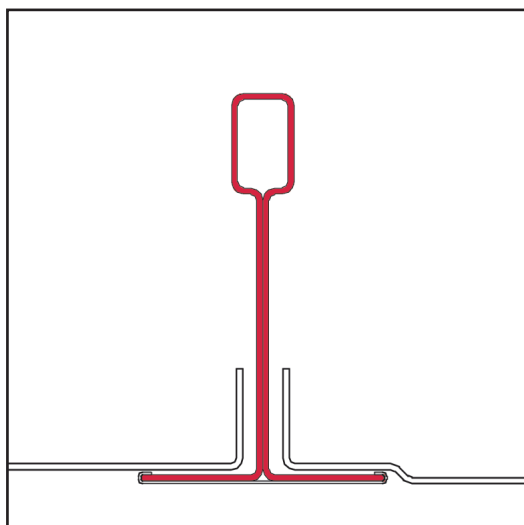

> Flexibility in visual impression:

- Coarse structure with tile joints
- Neat, harmonious lines with level or raised lay-in tiles

> Convenient installation:

- No tools required for installation and dismantling
- Easy even for persons without system training

> Immediate availability:

- Of T-rails
- Of lay-in tiles

Modul:	Formats:	Suspension:	Function:	Code:	Page:
625	600	wire 4 mm	Semi-concealed	KQV - 3.1.0.1 T24	38
600	575				38
600	584	wire 4 mm	Semi-concealed	KQV - 3.1.0.1 T15	39
625	620	wire 4 mm	Level	KQE - 3.1.0.1 T24	40
600	595				40
Perforation margins					42
Installation					43
Wall connection					69

Further information of the requirements of EN 13964 according to CE-standard mark

76 - 77

KQV
3.1.0.1 T24

FURAL® Acoustic Ceilings
Square tiles - lay-in system

Lay-in system for rail T24 - semi-concealed (HV)

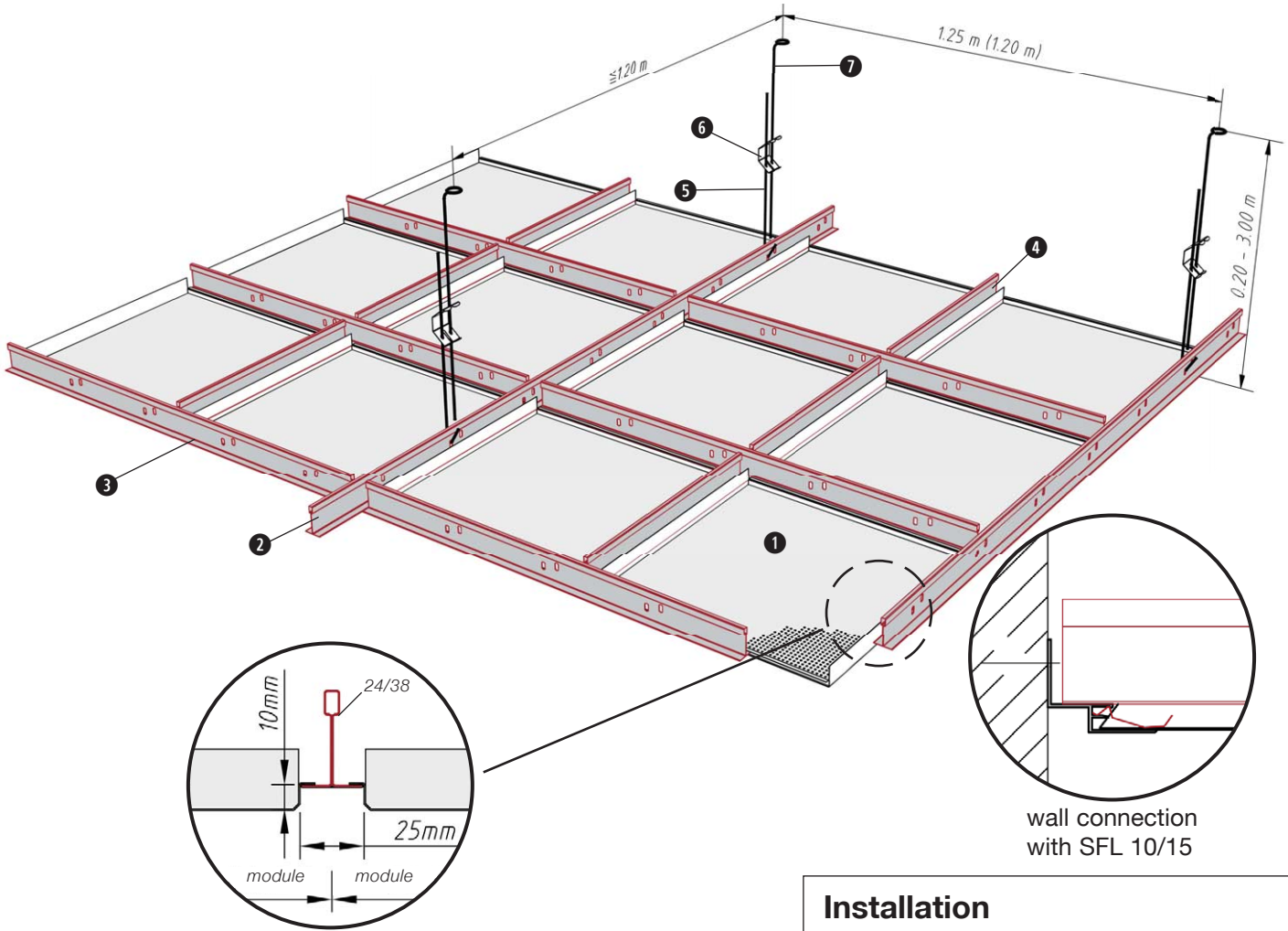

Only tiles with accurately bent edges ensure a harmonious visual impression of the entire ceiling.

Installation

Distance between fixing points according to the sketch
 Ceiling weight per m² aluminium app. 5 kg
 steel app. 8 kg
 further instructions: p. 43 and p. 76-77

Standard components

required: KQV 3.1.0.1 T24

Item	Designation	Module 625		Module 600	
		Rail T24	Units /m ²	Rail T24	Units/m ²
①	Semi-concealed (HV) tile	600 mm	2.56	575 mm	2.78
②	T support rail	L=3750 mm	0.21	L=3600 mm	0.23
③	T cross rail	L=1250 mm	1.28	L=1200 mm	1.39
④	T cross rail	L= 625 mm	1.28	L= 600 mm	1.39
⑤	Suspension wire with hook		0.67		0.70
⑥	Spring bracket		0.67		0.70
⑦	Suspension wire with loop		0.67		0.70

KQV
3.1.0.1 T15

FURAL® Acoustic Ceilings
Square tiles - lay-in system

Lay-in system for rail T 15 - semi-concealed (HV)

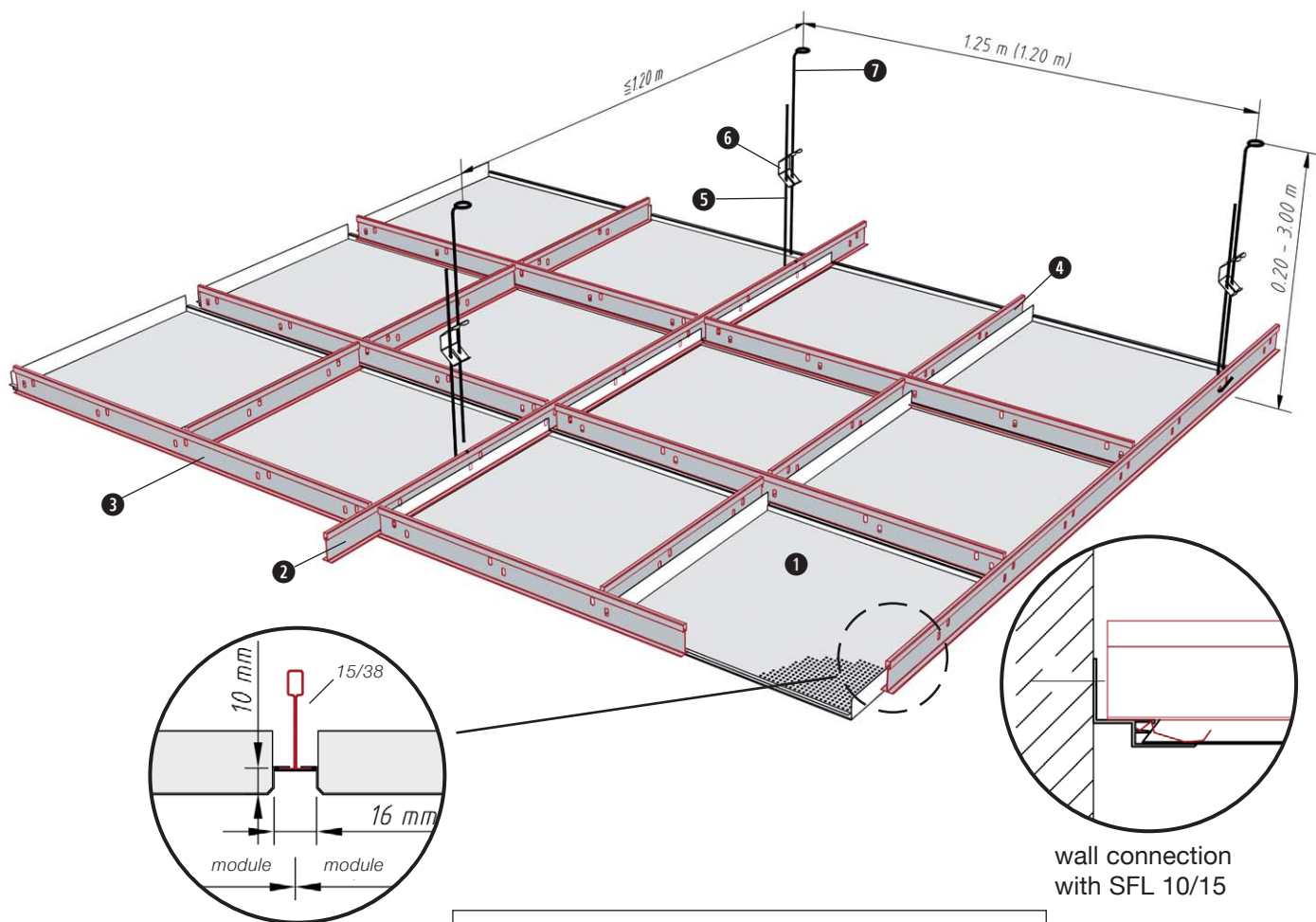

Somewhat finer joints with precisely fitting tiles.

Installation

Distance between fixing points according to the sketch

Ceiling weight per m² aluminium app. 5 kg

steel app. 8 kg

further instructions: p. 43 and p. 76-77

Standard components

required: KQV 3.1.0.1 T15

Module 600

Item	Designation	Rail T15	Units/m ²
1	Semi-concealed (HV) tile	584 mm	2.78
2	T support rail	L=3600 mm	0.23
3	T cross rail	L=1200 mm	1.39
4	T cross rail	L= 600 mm	1.39
5	Suspension wire with hook		0.70
6	Spring bracket		0.70
7	Suspension wire with loop		0.70

KQE
3.1.0.1 T24

FURAL® Acoustic Ceilings
Square tiles - lay-in system

Lay-in system for rail T 24 - level tiles

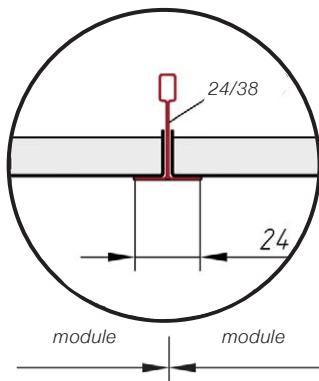
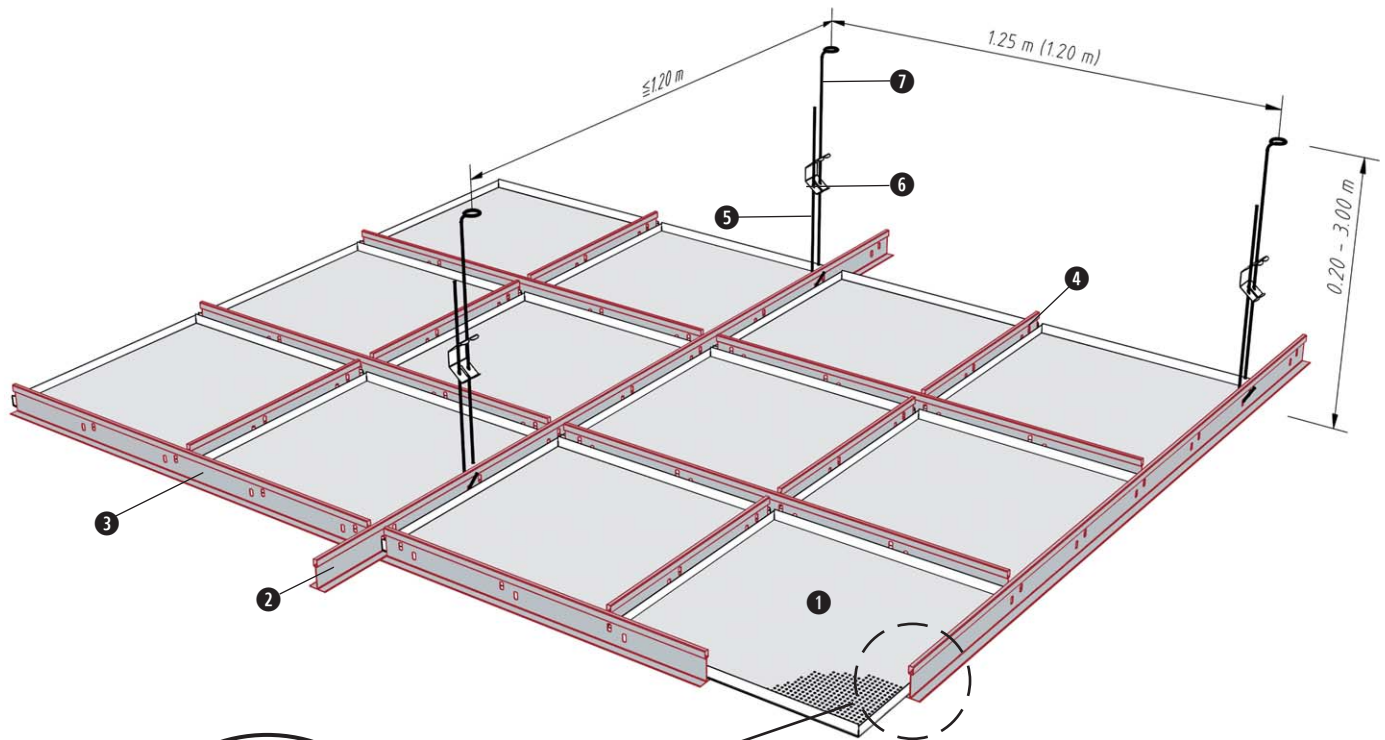

Installation

Distance between fixing points according to the sketch

Ceiling weight per m² aluminium app. 5 kg
 steel app. 8 kg

further instructions: p. 43 and p. 76-77

A solution of timeless elegance.

Standard components

required: KQE 3.1.0.1 T24

Item	Designation	Module 625		Module 600	
		Rail T24	Units/m ²	Rail T24	Units/m ²
1	Lay-in tile	620 mm	2.56	595 mm	2.78
2	T support rail	L=3750 mm	0.21	L=3600 mm	0.23
3	T cross rail	L=1250 mm	1.28	L=1200 mm	1.39
4	T cross rail	L= 625 mm	1.28	L= 600 mm	1.39
5	Suspension wire with hook		0.67		0.70
6	Spring bracket		0.67		0.70
7	Suspension wire with loop		0.67		0.70



for lay-in system

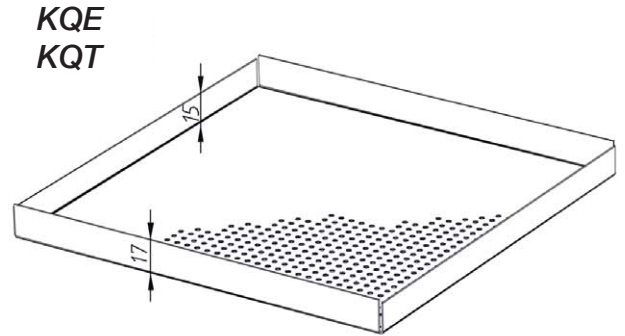
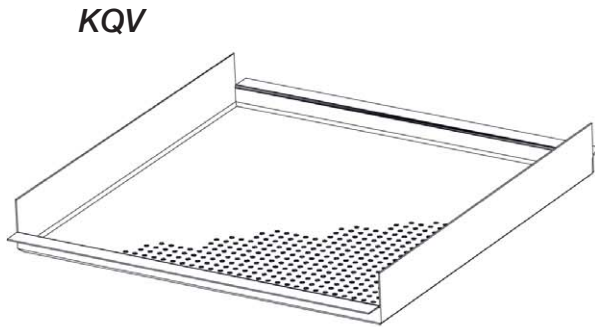

Module	Format
KQV 625	600 (T24) with bevel
KQV 600	575 (T24) with bevel
KQV 600	584 (T15) with bevel
KQV 625	600 (T24) sharp edged
KQV 600	575 (T24) sharp edged

Module	Format
KQE 625	620 (T24)
KQE 600	595 (T24)
KQT 625	620 (T24)
KQT 600	595 (T24)

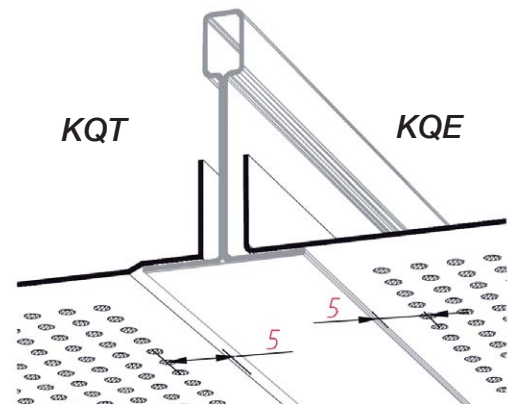
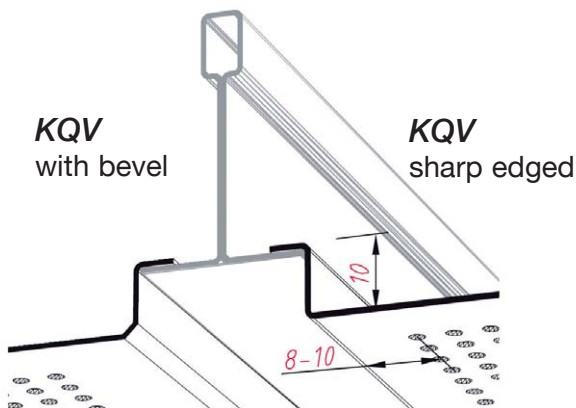
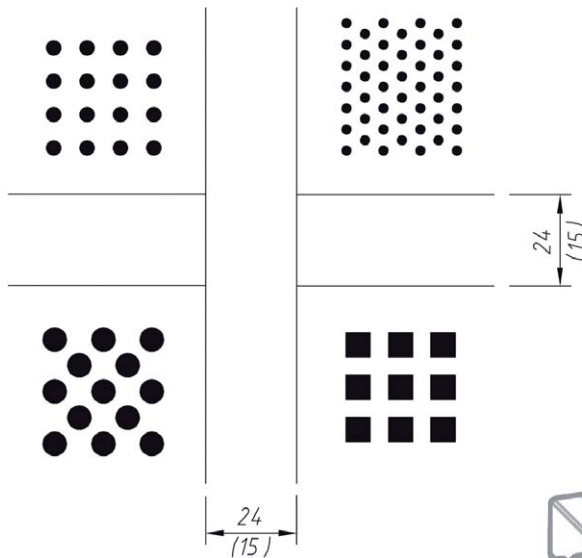

Suspension element installation

- Quick suspension element
 - Nonius suspension
- Support spacing:
- According to respective system description (page 38 – 42)
- Fastening materials:
- Use only fasteners suitable for the type of substrate and, where appropriate, with the necessary building authority approval
- Tools:
- Hammer drill (solid concrete), power drill
 - Depending on rawl plug and bolt types, hammer and/or spanners
- Installation procedure:
- Check whether any inbuilt parts (such as ventilation ducts, etc.) are installed too low in the ceiling cavity – if so, discuss with site manager
 - First mark suspension element position on the raw ceiling with a chalk line or laser and tape measure
 - Drill hole and insert rawl plug, fasten suspension element with bolt in rawl plug
 - Adjust suspension elements roughly to the required height

T-rail installation

- Normally, always install the T-rail in a longitudinal direction (supporting rail) parallel to the room's long side (with strip lighting also always parallel to the strip light's long side)
- Hook in the transverse rails with module spacing
- Now adjust the suspension elements precisely to the ceiling height

Tile installation

- Unpack and install the tiles - always wear ceiling installer gloves when working in order to avoid soiling
- Always install the first complete row of tiles on the longer side of the room and check whether the tile edges are in line and run parallel to the wall. Mark the exact tile edge with a line tied from wall to wall or with a rotating laser
- Install the cut tiles in the open space remaining between the wall and the first complete row of tiles, and then install the next complete row of tiles, etc.
- For the cut tiles, measure the distance from the edge of the tile to the front edge of the edge profile and

- add + 15 mm for the support - this is the cutting dimension
- Cut the tile to size using an electric nibbler or sheet metal shears
- Push in the cut tile at a slight angle from below between the upper edge of the edge bracket and the lower edge of the trimming, turn the front edge of the cut tile also to a slight angle relative to the front edge of the edge bracket to allow the tile to be pressed in more easily, then press the tile web into the T-rail
- In the corner of the room, always install the corner tile with two cut sides first, then the cut tile alongside the corner tile

Tile removal

- Lift out the tiles easily, without using tools, into the ceiling cavity and guide them down through the opening

Information

For variants of the different ceiling systems, see system descriptions in the ceiling manual. Please also note the information regarding the requirements of EN 13964 relating to the CE standard marking on pages 76 – 77.



S



ACOUSTIC CERTIFIED

STRIP GRID SYSTEM

ADVANTAGES :

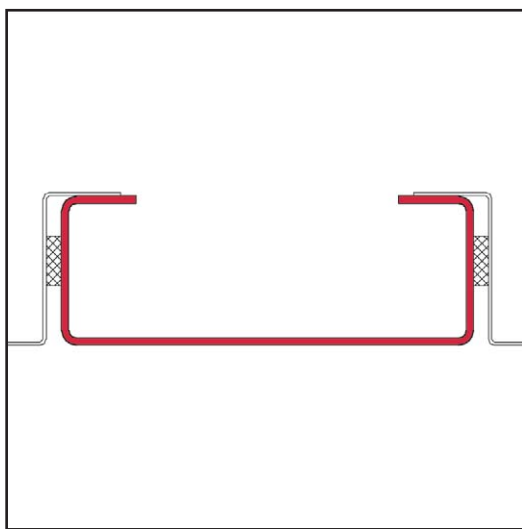

> A high degree of flexibility

- Adjustment to the construction grid
- Incorporation of partition walls
- Can be upgraded to meet strict longitudinal sound absorption requirements

> Convenient installation:

- No tools required for dismantling
- Minimum suspension height is possible

> Visual advantages:

- Tile- and strip grid sections are precisely aligned
- Uniform coating of all visible components

Formats:	Grid:	Suspension:	Function:	Code:	Page:
Long span	with grid	nonius suspension	longitudinal strip grid	KLB - 5.2.1.2 Längs	46
Long span	without grid	nonius suspension	cross strip grid	KLB - 5.2.0.2 Kreuz	47
Long span	without grid	nonius suspension	French Hook	KLB - 5.2.0.2 Längs	48
Joints/Edges/Webs/Strip grid					50
Installation					51
Long span		threaded rod	node strip gride	KLB - 5.2.0.5 Knoten	52
Further information of the requirements of EN 13964 according to CE-mark					76 - 77

KLB

5.2.1.2 Längs

FURAL® Acoustic Ceilings

Long span tiles – strip grid system

Longitudinal strip grid with double grid

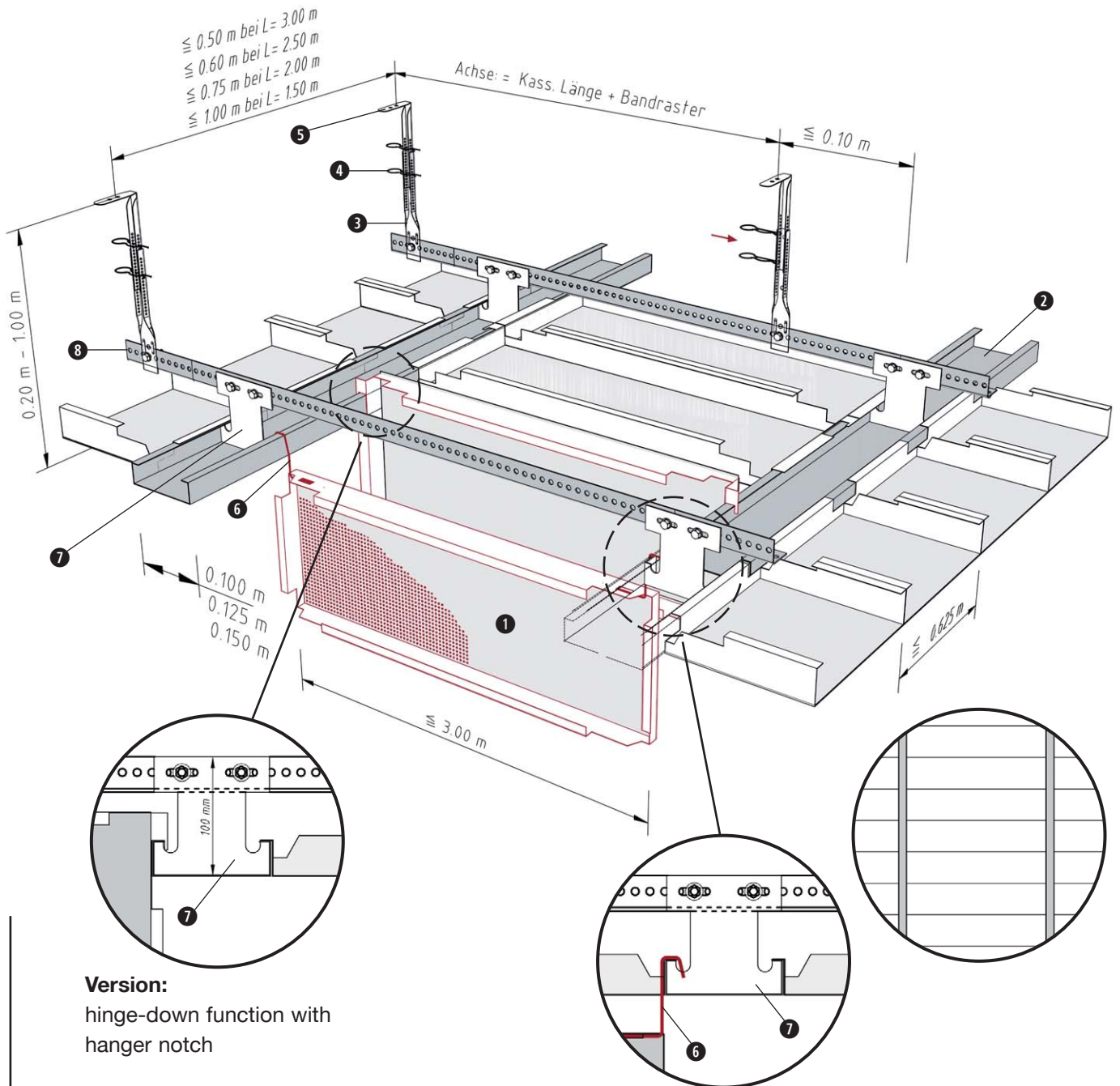

The only strip grid ceiling with hinged tiles.

Installation

Distance between fixing points according to the sketch

Ceiling weight per m² steel app. 10 kg

further instructions: p. 51 and p. 76-77

- 1 Strip grid tile
- 2 Main runner (strip grid)
- 3 Lower nonius
- 4 Securing pin
- 5 Upper nonius
- 6 DOOR wire bracket
- 7 Grid element hanger
- 8 Grid bracket 30/30

KLB
5.2.0.2 Kreuz

FURAL® Acoustic Ceilings
Long span tiles – strip grid system

Cross strip grid without double grid

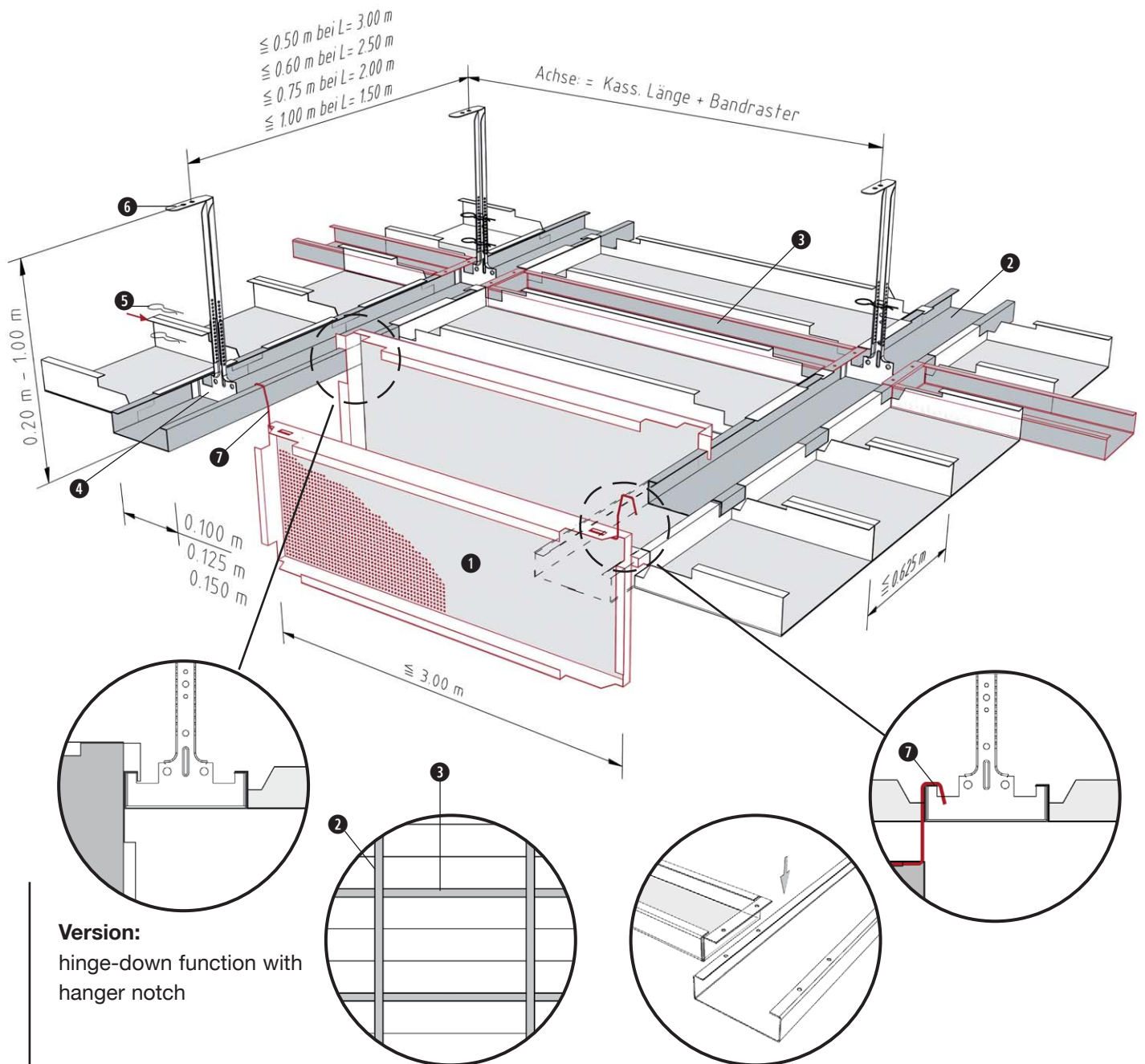

Version:

hinge-down function with hanger notch

The advantages of cross strip grid with hinged tiles.

Installation

Distance between fixing points according to the sketch

Ceiling weight per m² steel app. 10 kg

further instructions: p. 51 and p. 76-77

- ❶ Strip grid tile
- ❷ Main runner (strip grid)
- ❸ Secondary runner (strip grid)
- ❹ Lower nonius for strip grid
- ❺ Securing pin
- ❻ Upper nonius
- ❼ DOOR wire bracket

KLB
5.2.0.2 Längs

FURAL® Acoustic Ceilings
Long span tiles – strip grid system

Longitudinal strip grid with French Hook (Fire stability see NBN 713.020)

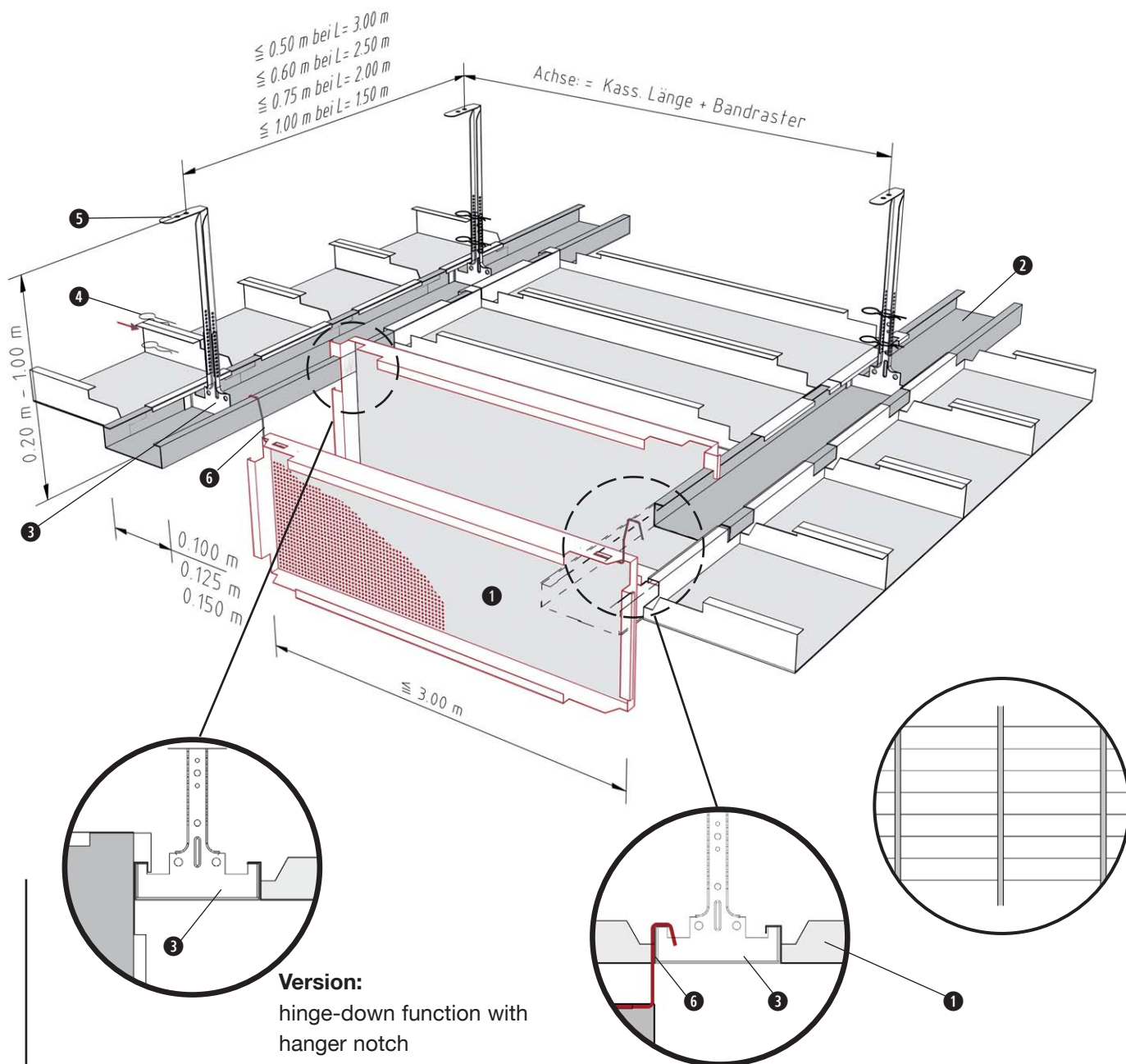

*The strip grid ceiling with
French Hook for more stability.*

Installation

Distance between fixing points according to the sketch

Ceiling weight per m² steel app. 10 kg

further instructions: p. 51 and p. 76-77

- ① Strip grid tile with French Hook
- ② Main runner (strip grid)
- ③ Lower nonius for strip grid
- ④ Securing pin
- ⑤ Upper nonius
- ⑥ DOOR wire bracket

Details

FURAL® Acoustic Ceilings Joints/Edges/Webs/Strip grid

for strip grid system

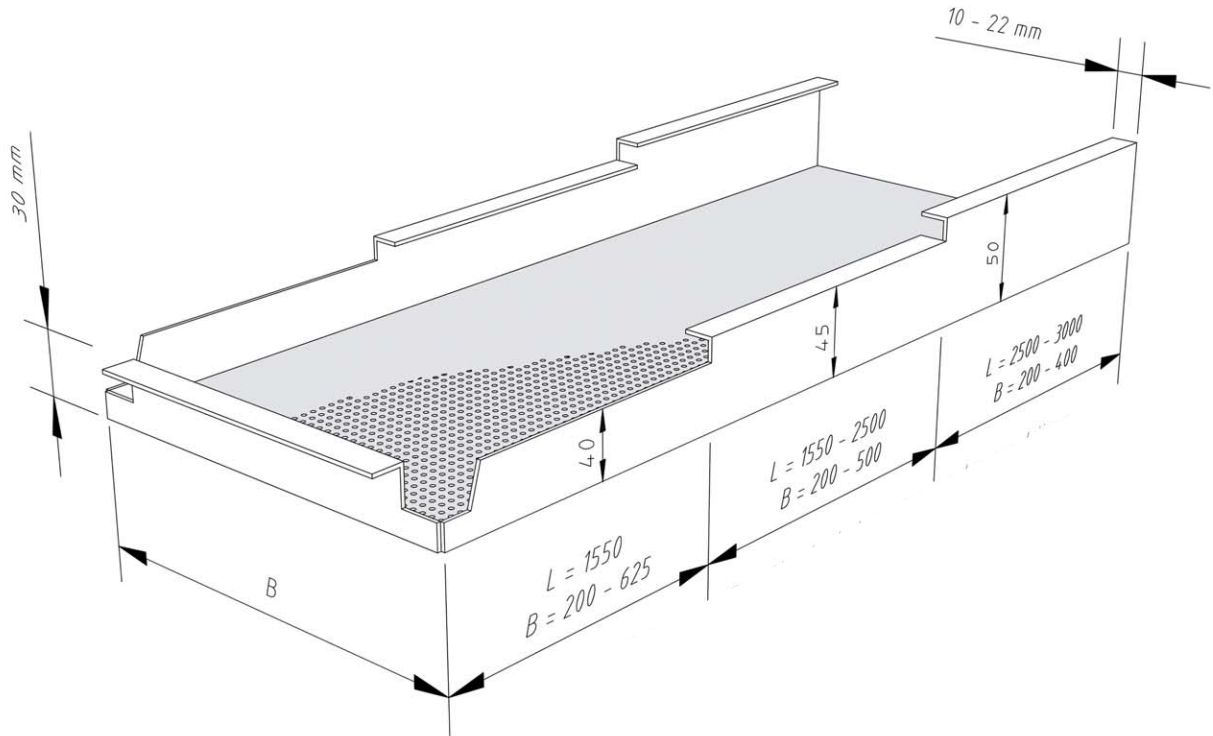

Standard

French Hook

grid element

Tile front side

grid element

Tile front side

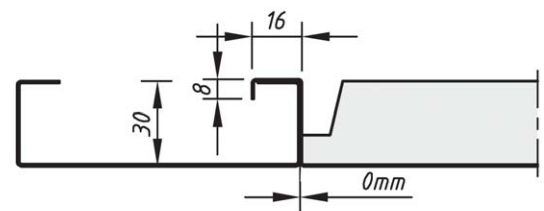
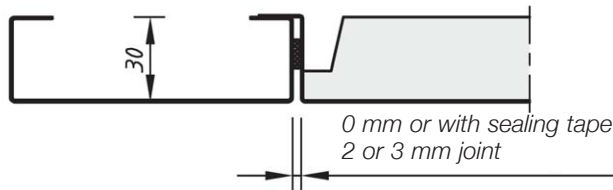

Tile long side

Tile long side

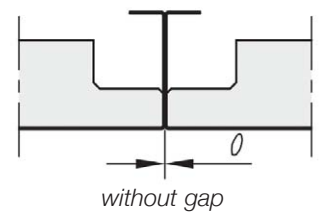
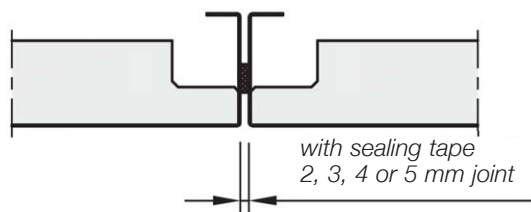

Strip grid

Joints



for strip grid system

Standard widths: 100/125/150
(Special dimensions upon inquiry)

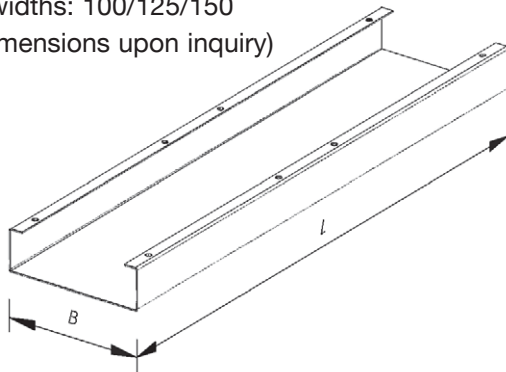

Cross grid element
W: 100/125/150

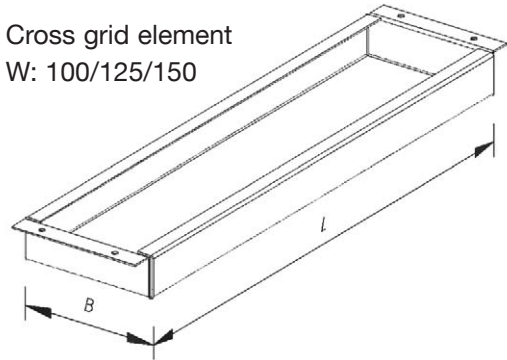

Lower nonius for strip grid
(suitable for the respective
grid element width)

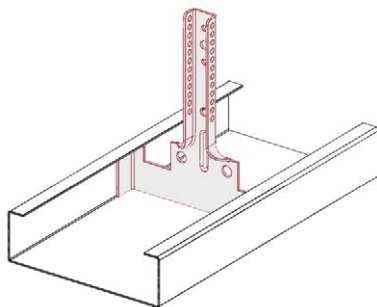

Grid element connector
(suitable for the respective
grid element width)

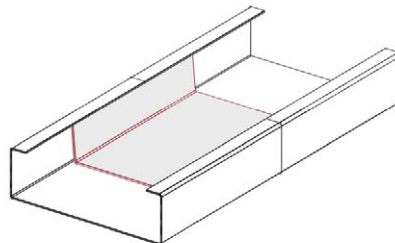

Grid element wall mounting set
(suitable for the respective
grid element width)

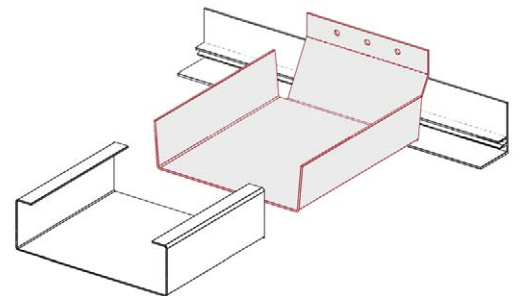

Optional:
Grid element and grid element connector
with release tab

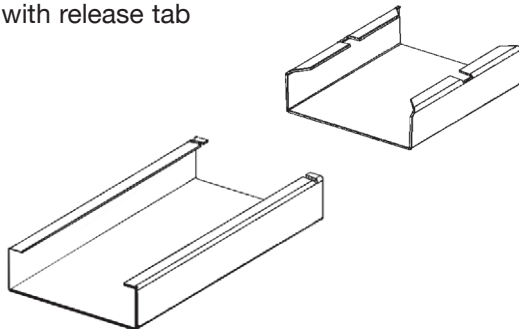

To lock the grid element push down the
release tab

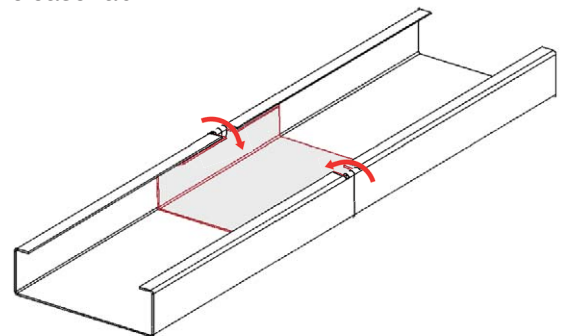

Suspension element installation

- Nonius suspension

Support spacing:

- According to respective system description (page 46 – 48)

Fastening materials:

- Use only fasteners suitable for the type of substrate and, where appropriate, with the necessary building authority approval

Tools:

- Hammer drill (solid concrete), power drill
- Depending on rawl plug and bolt types, hammer and/or spanners

Installation procedure:

- Check whether any inbuilt parts (such as ventilation ducts, etc.) are installed too low in the ceiling cavity – if so, discuss with site manager
- First mark suspension element position on the raw ceiling with a chalk line or laser and tape measure
- Drill hole and insert rawl plug, fasten suspension element with bolt in rawl plug
- Adjust suspension elements roughly to the required height

Strip grid installation

- Longitudinal strip grid
 - Attach single-rail grid at nonius hangers using M6 x 20 mm bolts (including washers) and install strip grid suspension elements, longitudinal strip grid direction normally at right angles to the façade
- Cross-strip grid
 - Install longitudinal strip grid on strip grid using lower nonius, longitudinal strip grid direction normally at right angles to the façade
 - Place cross-strip grid with Z-edge-fold on longitudinal strip grid and screw or rivet in place
- Strip grids – general
 - Use the strip grid coupling at strip grid butt joints
 - Use wall shoe at the end of the profile (protection against twisting)
 - Provide sufficient transverse stiffening for the strip grid, depending on the suspension height
 - Now adjust the suspension elements precisely to the ceiling height

Tile installation

- Unpack and install the tiles - always wear ceiling installer gloves when working in order to avoid soiling
- Always install the first complete row of tiles on the longer side of the room and check whether the tile edges are in line and run parallel to the wall. Mark the exact tile edge with a line tied from wall to wall or with a rotating laser, ensuring that the tiles do not interlock at the corners – install precisely corner to corner
- Install the cut tiles in the open space remaining between the wall and the first complete row of tiles, and then install the next complete row of tiles, etc.
- For the cut tiles, measure the distance from the edge of the tile to the front edge of the edge profile and add + 15 mm for the support - this is the cutting dimension
- Cut the tile to size using an electric nibbler or sheet metal shears
- Push in the cut tile at a slight angle from above between the upper edge of the edge bracket and the lower edge of the trimming, turn the front edge of the cut tile also to a slight angle relative to the front edge of the edge bracket to allow the tile to be pressed in more easily, then rest the tile web on the strip grid
- In the corner of the room, always install the corner tile with two cut sides first, then the cut tile alongside the corner tile

Tile removal

- Lift out the front end of the tile easily, without using tools, over the strip grid into the ceiling cavity and guide it down through the opening

Information

For variants of the different ceiling systems, see system descriptions in the ceiling manual. Please also note the information regarding the requirements of EN 13964 relating to the CE standard marking on pages 76 – 77.

KLB
5.2.0.5 Knoten

FURAL® Acoustic Ceilings
Long span tiles – strip grid system

Node strip grid

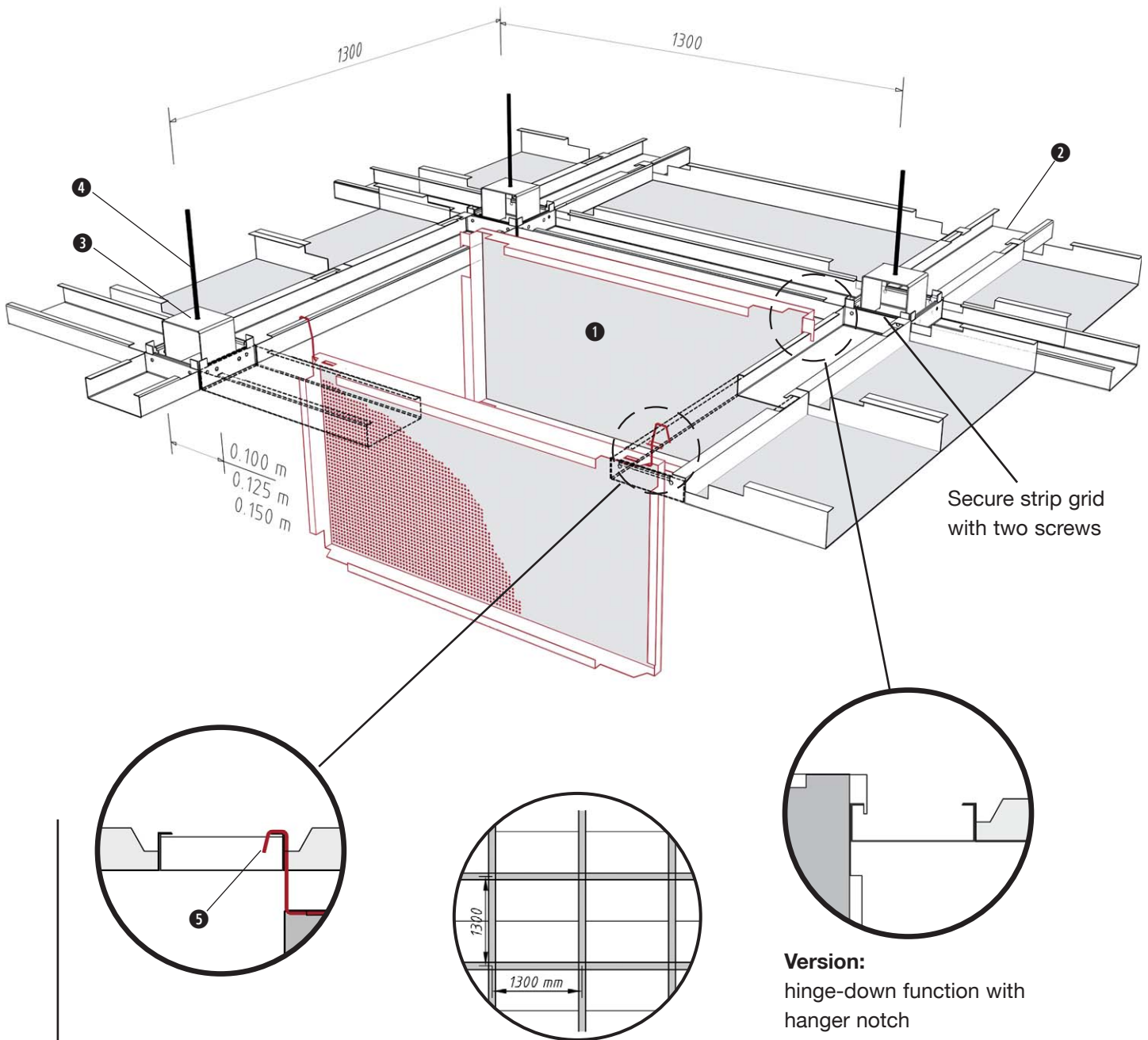

Installation

Distance between fixing points according to the sketch
 Ceiling weight per m² steel app. 10 kg
 further instructions: p. 51 and p. 76-77

- ① Strip grid tile
- ② Main runner (strip grid)
- ③ Node
- ④ Threaded rod M6
- ⑤ DOOR wire bracket

Node strip grid

Node

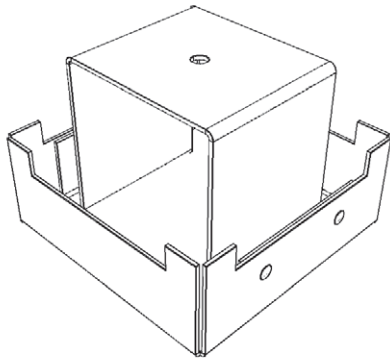

Suspension with threaded rod M6

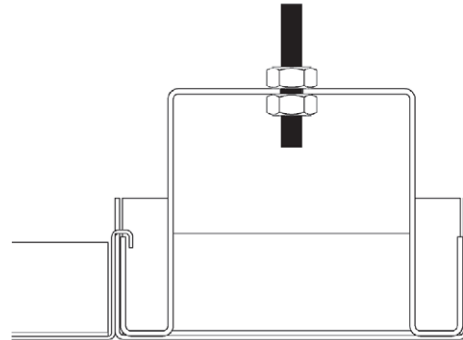

Standard widths with edgelifolding for node
 W: 100/125/150

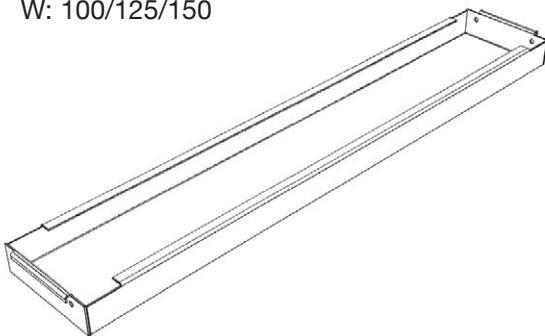

Hang in grid element on the node sides
 and secure with 2 screws

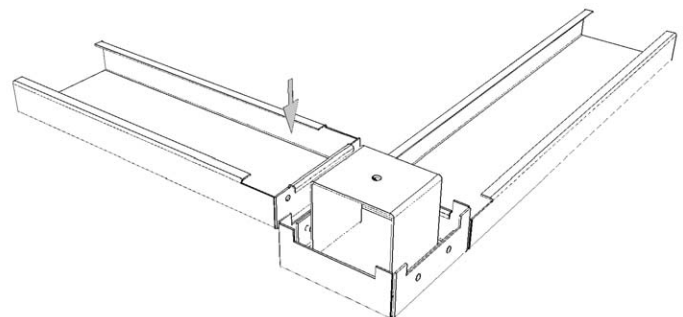

Depending on the axial dimension, main runners as well as the cross runners separately centered must be in case they are loaded. For this purpose, a grid element wall mounting can be used.

The dimensioned ceiling module here (1300 x 1300 mm) serves as an example. Other modules are possible in accordance with our production options.

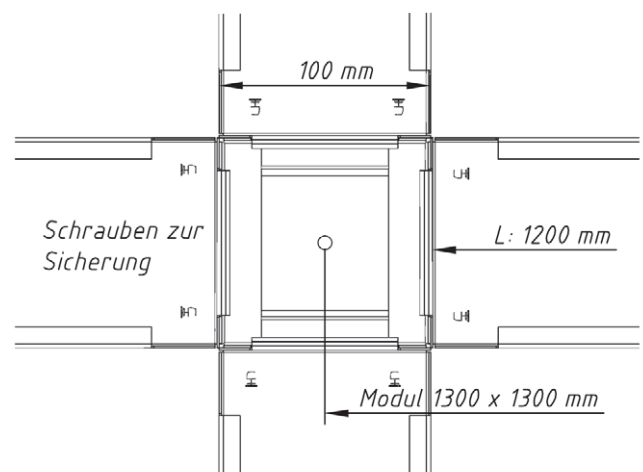

Further installation instructions
 see page 51



S SUPPORT SYSTEM



ADVANTAGES :

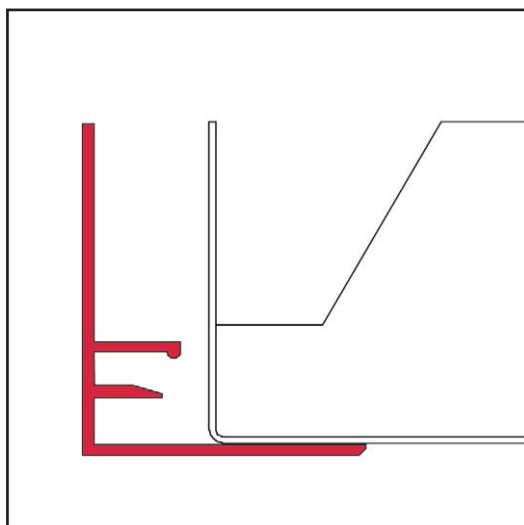

A high degree of flexibility:

- Available on short notice
- Ideal adaptation to special features of the building structure

Excellent visual impression:

- Support on existing angles
- Large selection of **FURAL**-(shadow) wall mounting sections

Most convenient installation:

- Easy even without knowledge of the system

Formats:	Subconstruction:	Code:	Page:
Long span	wall mounting	KLE	56
Long span	steel-wall bracket fire stable	KLE SF	58
Long span	steel-wall bracket fire stable	KLE SJ	59
Long span	steel-wall bracket fire stable	KLE SL	60
Installation			61

Further information of the requirements of EN 13964 according to CE-mark

76 - 77

Support on edge profile

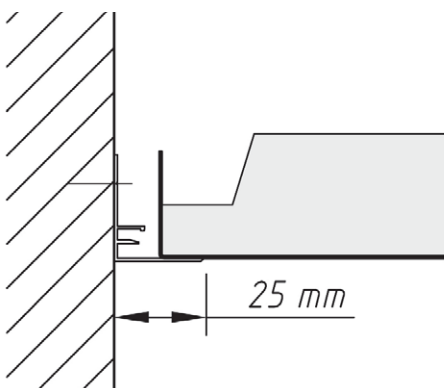
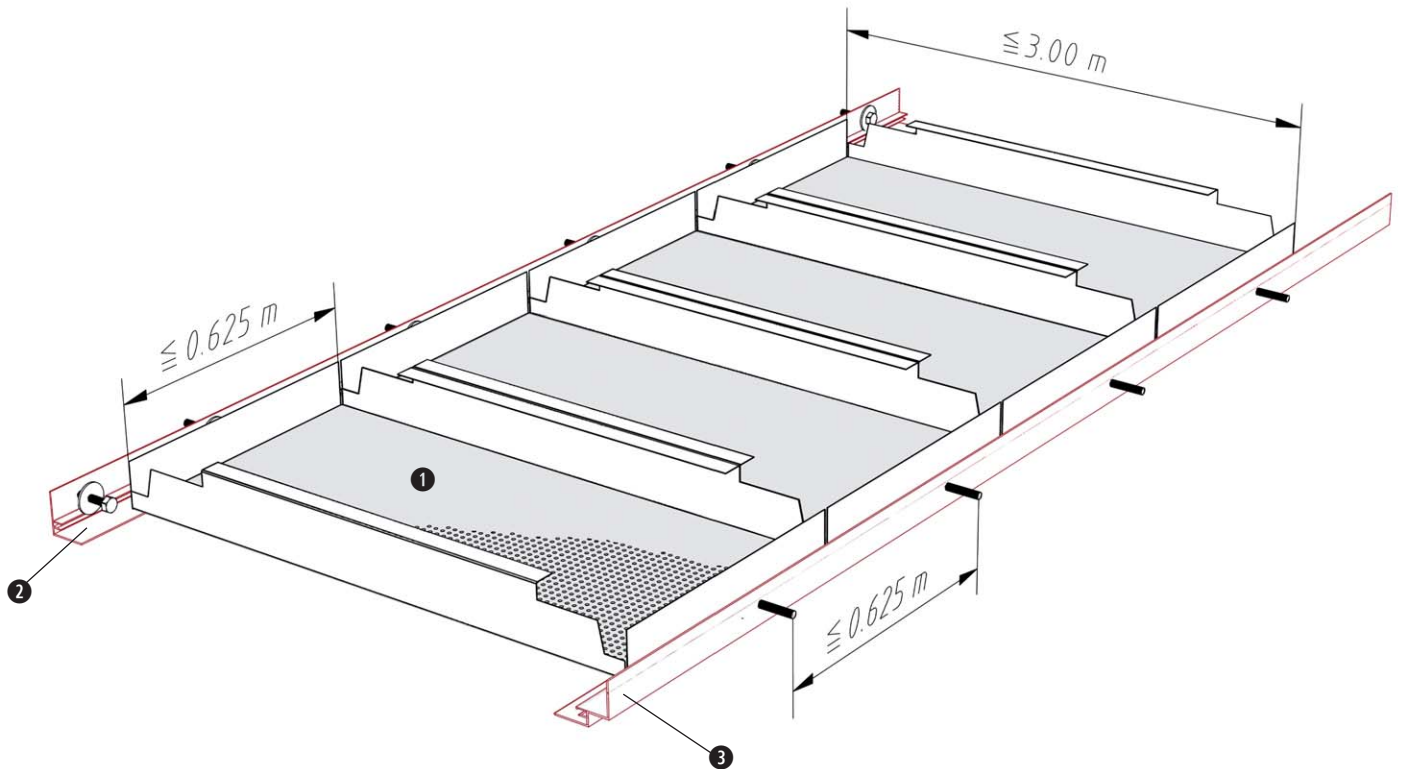

Tile support for entire tile

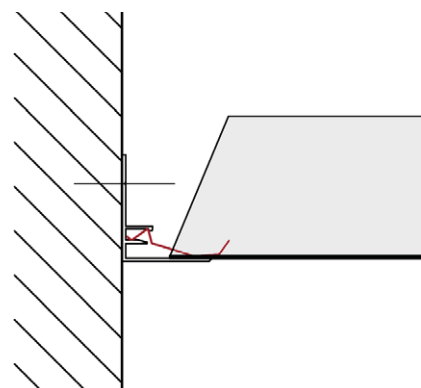

Tile support for cut-off tile

Installation

Distance between fixing points are ≤ 625 mm
 Ceiling weight per m² alu app. 3 kg, steel app. 5 kg
 max. size: L = 3,000mm, B = 625mm
 further instructions: p. 60 and p. 76-77

- ❶ Tile
- ❷ Trimming section
- ❸ Shadow trimming section

Support on edge profile

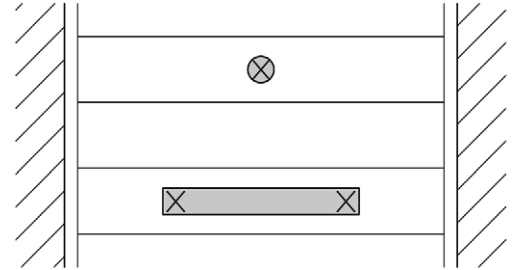
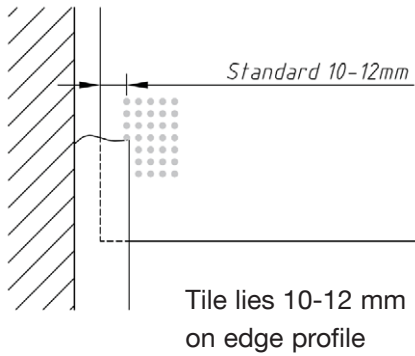

Installation of light fittings: (Direct suspension)

Longitudinal webs

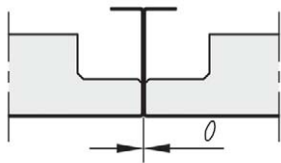

without gap

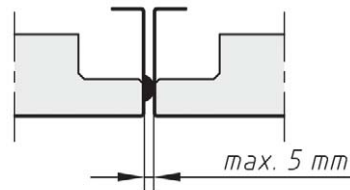

distance embossing

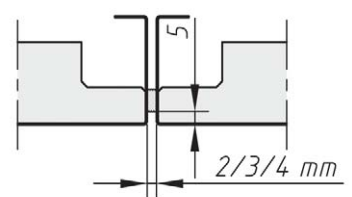

sealing tape

Apron for difference in ceiling level

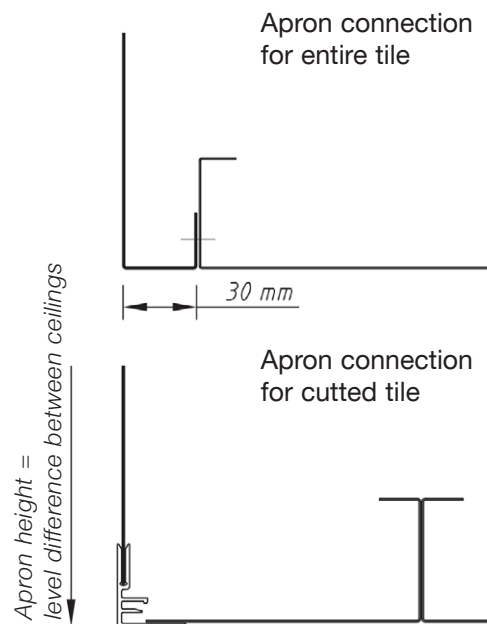
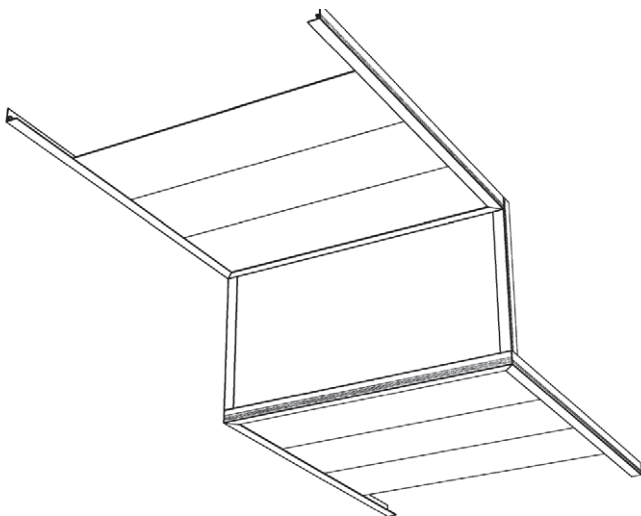

**KLE
SF**

FURAL® Acoustic Ceilings Support system

Support on SF-trimming profile (fire stability according to NBN 713.020)

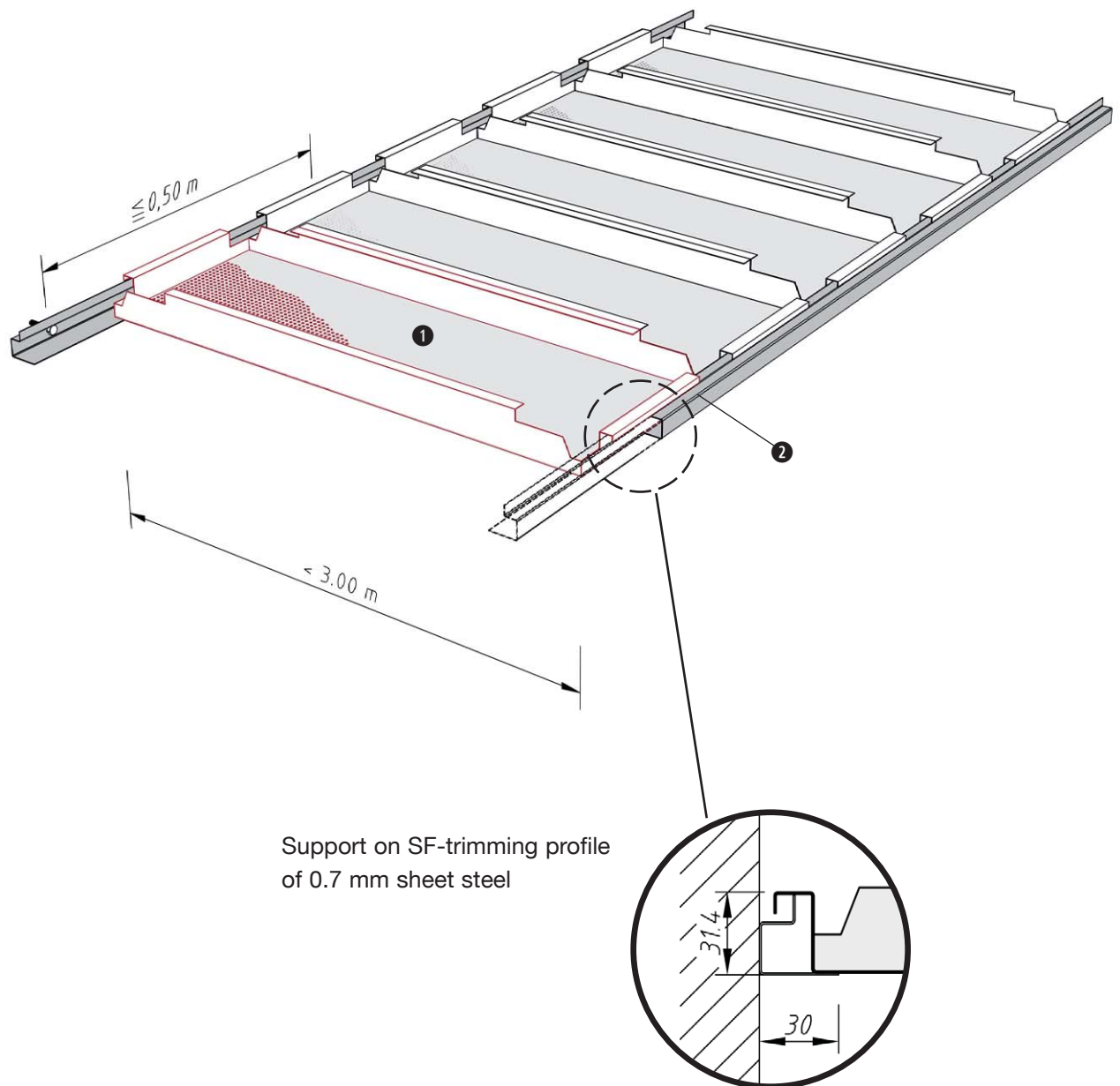

Support on SF-trimming profile
of 0.7 mm sheet steel

Installation

Distance between fixing points are ≤ 500 mm

Ceiling weight per m² steel app. 5 kg

max. size: L = 3,000mm, B = 600mm

further instructions: p. 60 and p. 76-77

- ❶ Tile
- ❷ SF-trimming profile

**KLE
SJ**

FURAL Acoustic Ceilings Support system

Support on SJ-trimming profile (fire stability according to NBN 713.020)

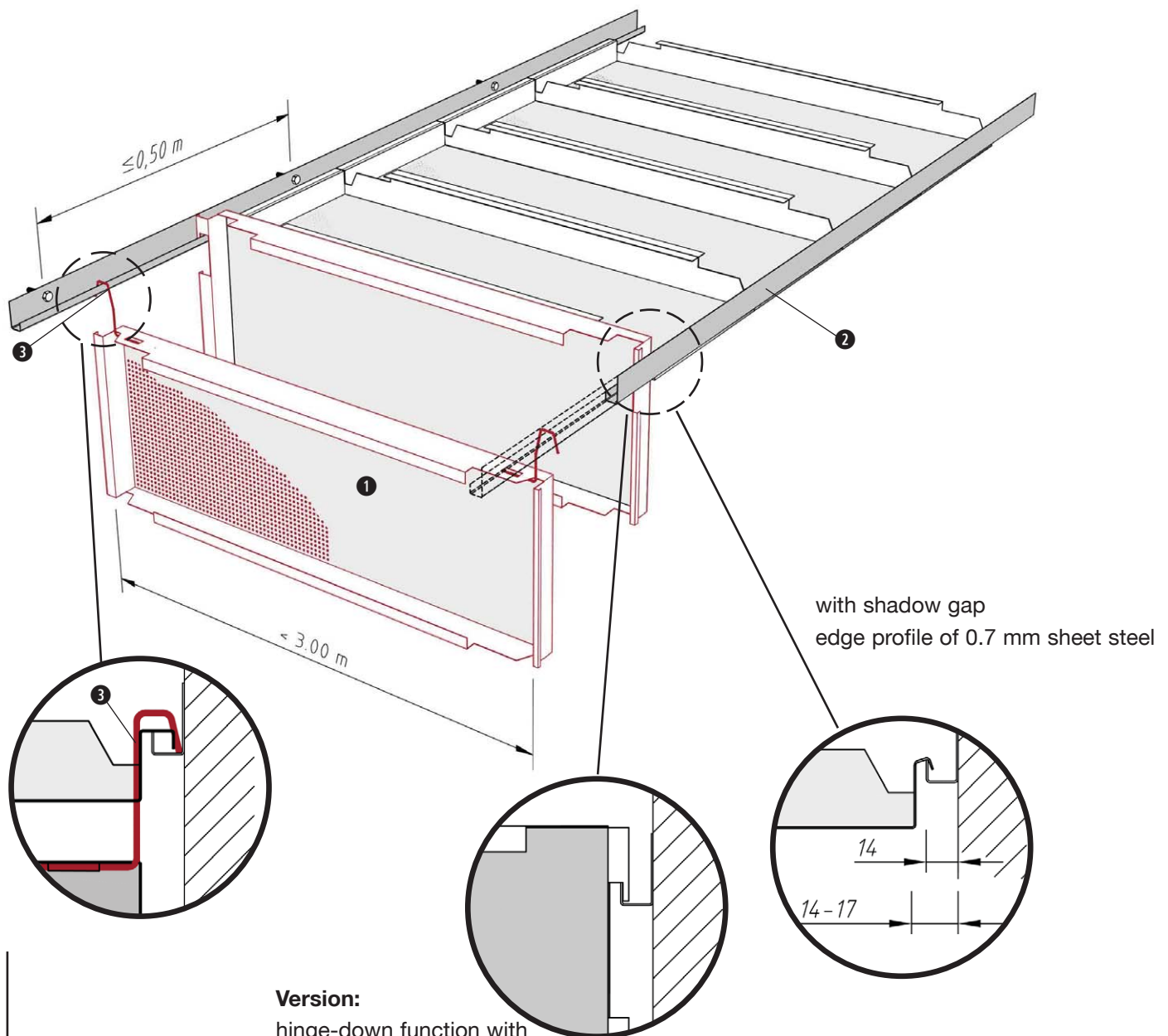

Version:
hinge-down function with
hanger notch

Installation

Distance between fixing points are ≤ 500 mm
Ceiling weight per m² steel app. 5 kg
max. size: L = 3,000mm, B = 600mm
further instructions: p. 60 and p. 76-77

- ❶ Tile
- ❷ SJ-trimming profile 31/14/10
- ❸ DOOR-wire bracket

**KLE
SL**

FURAL Acoustic Ceilings Support system

Support on SL-trimming profile (fire stability according to NBN 713.020)

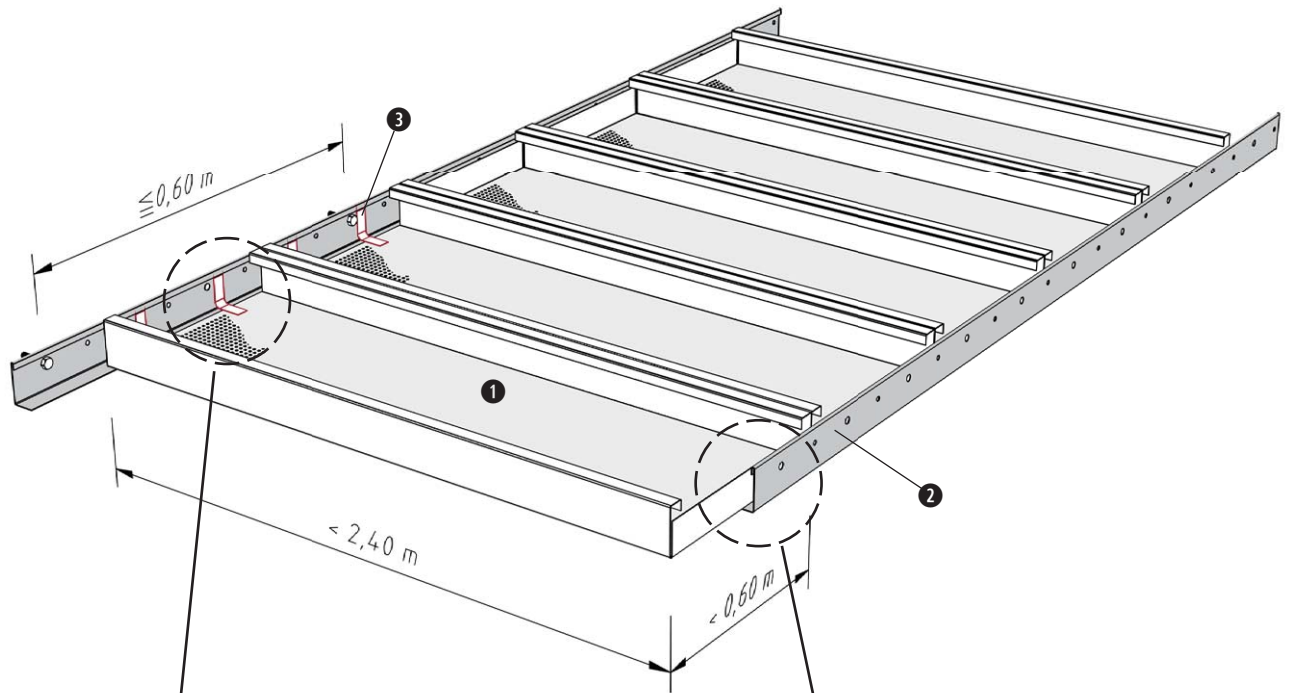

Fix cutted tile with 2 pieces of springs per tile

Edge profile of 0,75 mm sheet steel
Support for entire tile

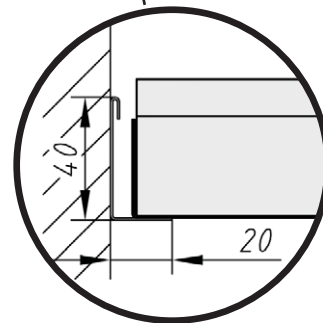
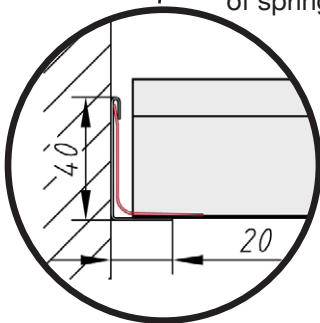

Installation

Distance between fixing points are ≤ 600 mm

Ceiling weight per m^2 steel app. 5 kg

max. size: L = 2,400mm, B = 600mm

further instructions: p. 60 and p. 76-77

- ① Tile
- ② SL-trimming profile
- ③ Fixing spring for SL-trimming profile

Edge profile installation

- Trimming section 30/25 mm
- Shadow trimming section 15/10 mm
- Shadow trimming section 20/20 mm
- Shadow trimming section 25/25 mm
- Shadow trimming section 30/30 mm
- Picture rail 15/10 mm
- Steel edge profile SF, SJ, SL (please observe special notes "FIRE STABILITY")

Support spacing:

- ≤ 625 mm (see ceiling manual, page 71)
- For steel edge profile SF, SJ, SL („FIRE STABILITY“) see system descriptions on page 58, 59, 60

Fastening materials:

- Use only fasteners suitable for the type of substrate and, where appropriate, with the necessary building authority approval

Tools:

- Make horizontal reference height mark for installation with a laser or chalk line
- Cut to length and mitre cut with Ø 220 – 250 mm mitre saw blade with 50 carbide teeth
- Hammer drill (solid concrete), power drill
- Depending on rawl plug and bolt types, hammer and/or spanners

Fixing springs, trimming and shadow trimming sections, aluminium:

- 6 per linear metre edge profile
- Use with cut tiles
- Press in fixing springs just before installing the cut tiles (for precise position in the trimming section, see ceiling manual, page 71)
- For room corners, use mitre connection

Springs for SL edge profile ("FIRE STABILITY")

- 2 per tile end face
- Use with cut tiles
- Press in fixing springs just before installing the cut tiles (for precise position in the SL edge profile, see ceiling manual, page 60)

Installation procedure:

- Always make the horizontal reference height mark on the upper edge of the edge profile
Horizontal reference height = ceiling height + profile height
- Check whether any inbuilt parts (such as ventilation

ducts, etc.) are installed too low in the ceiling cavity – if so, discuss with site manager

Tile installation

- Unpack and install the tiles - always wear ceiling installer gloves when working in order to avoid soiling
- Never cut the tiles shorter than the distance from edge profile front edge to edge profile front edge plus 20 mm (applies to trimming and shadow trimming sections, aluminium)
- For SL edge profile („FIRE STABILITY“), from edge profile front edge to edge profile front edge plus 30 mm
- Cut the tile to size using an electric nibbler or sheet metal shears
- Push in the cut tile at a slight angle from above between the upper edge of the edge bracket and the lower edge of the trimming, turn the front edge of the cut tile also to a slight angle relative to the front edge of the edge bracket to allow the tile to be pressed in more easily, then rest the tile web on the edge strip of the parallel wall
- In the corner of the room, always install the corner tile with two cut sides first, then the cut tile alongside the corner tile

Tile removal

- Lift out the tiles easily, without using tools, into the ceiling cavity and guide them down through the opening
- Pay attention to any fixing springs that may be installed

Information

For variants of the different ceiling systems, see system descriptions in the ceiling manual. Please also note the information regarding the requirements of EN 13964 relating to the CE standard marking on pages 76 – 77.





SWING OUT / SLIDING CEILINGS

ADVANTAGES :

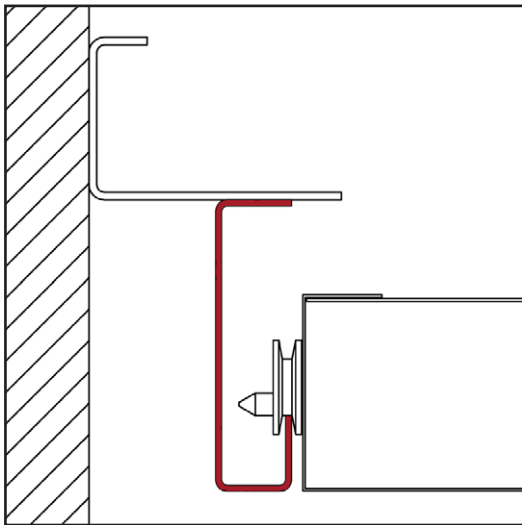

› Maximum comfort:

- Each tile can be swung out and slid by the use of wheels.
- Large areas can be opened for maintenance or inspection with a twist of the wrist
- You determine the position and size of inspection areas

› Visual advantages:

- These riveted tiled ceilings ensure optimum visual impression, even after repeated dismantling and re-assembling of the ceiling.
- Formats/perforation/colours: a wide variety of design options
- No disruptive inspection doors

Formats:	Substructure:	Function:	Page:
Long span	wall mounting	SWING	64 - 66
Installation			67
Further information of the requirements of EN 13964 according to CE-mark			76 - 77

Swing out /
Sliding ceilings

FURAL® Acoustic Ceilings Long span tiles

Long span tile type "SWING"

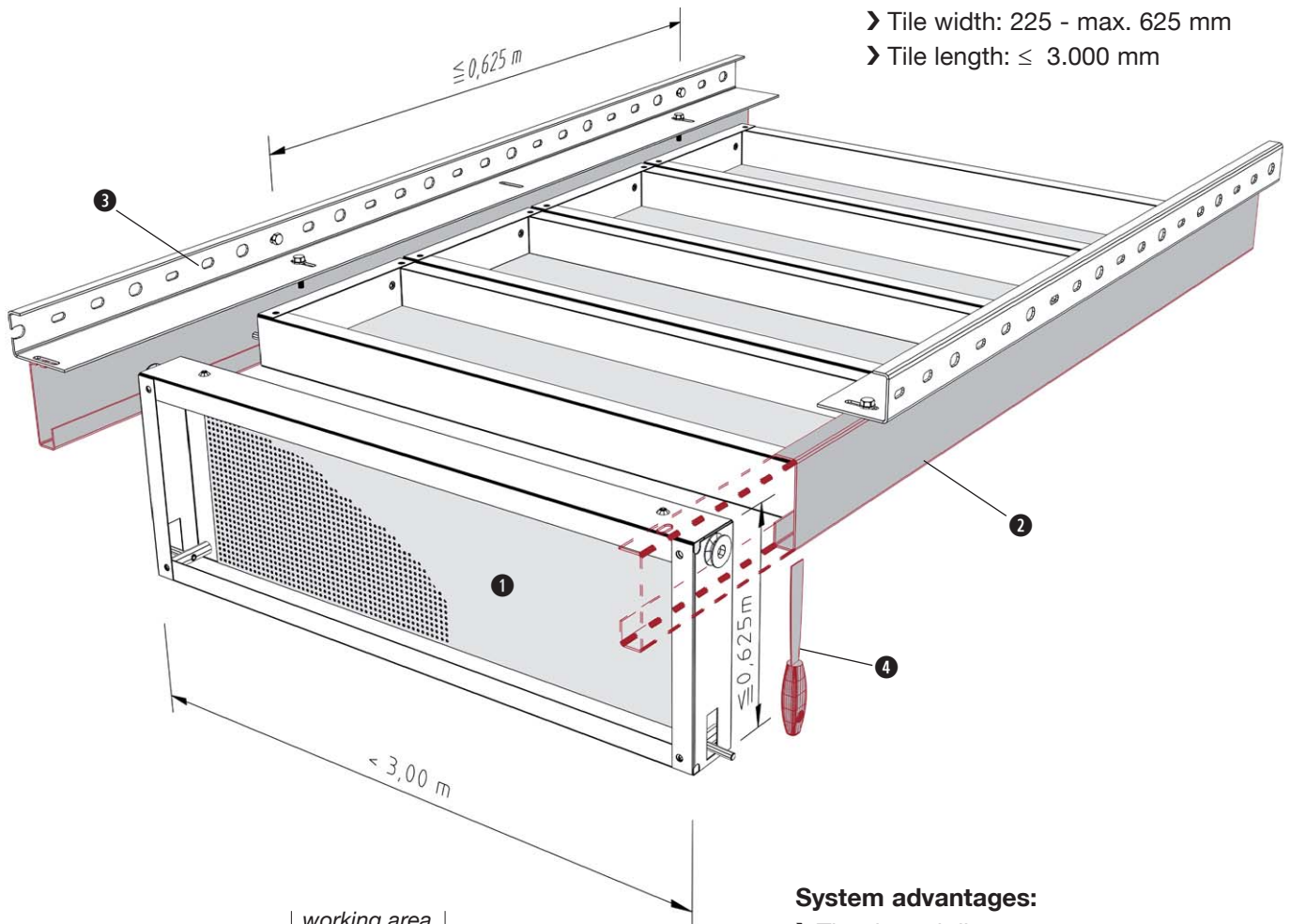

- › Tile width: 225 - max. 625 mm
- › Tile length: ≤ 3.000 mm

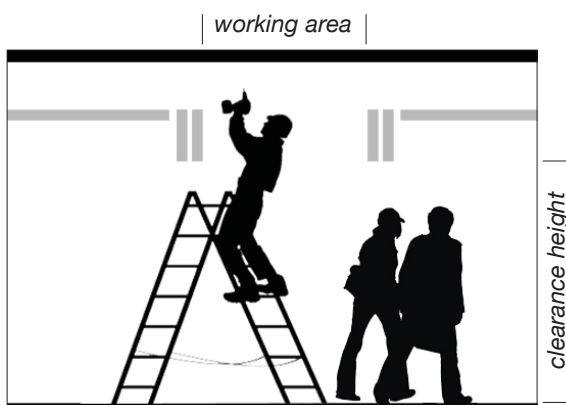

System advantages:

- › The riveted tile corners guarantee an outstanding appearance, even after frequent removal and refitting
- › No inspection doors necessary
- › Ceiling elements remain in the substructure, therefore no risk of injuring people underneath nor of damaging the ceiling elements
- › Undisturbed movement of people / office activity possible even in case of major maintenance work.

Installation

Distance between fixing points is ≤ 625 mm
 Ceiling weight per m^2 steel app. 7 kg
 max. size: L = 3000mm, B = 625mm
 further instructions: p. 67 and p. 76-77

- ① Tile type SWING (with 2 twist locks and 2 turning disks)
- ② G-support section
- ③ U-Wall mounting angle
- ④ Ceiling opener for unlocking the tile with hidden twist lock

Versions

Hidden twist lock: Perfect in form and function

- › Hidden opening mechanism
- › Tile released with trowel in the 3 mm tile joint (tile face side)

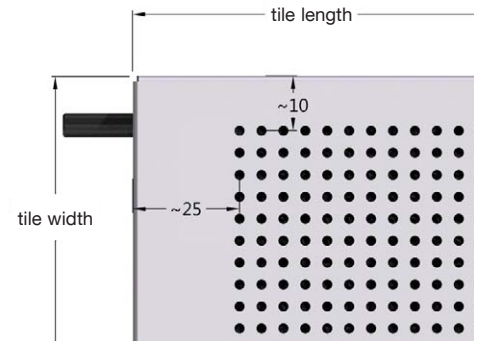
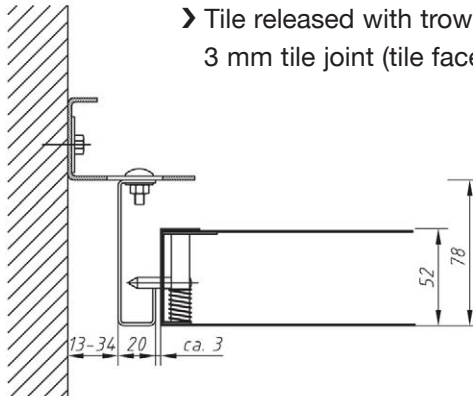

Visible twist lock: The right rotation

- › Visible opening mechanism
- › Unlock tile with 5 mm Allen key

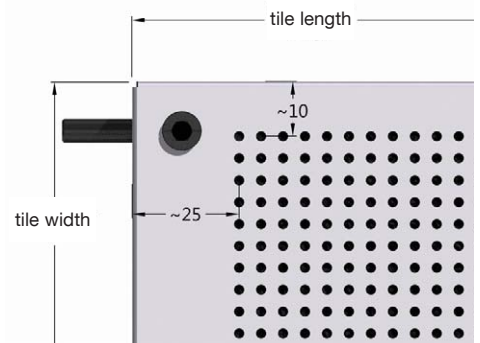
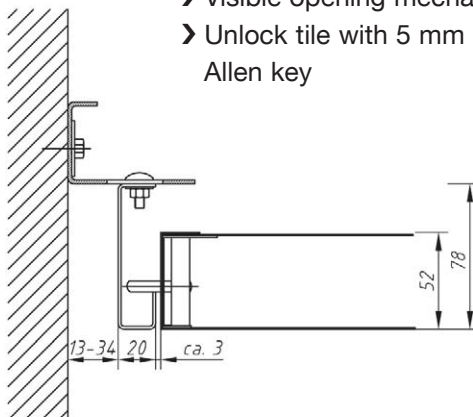

Support roller: Automatic fixing

- › The support roller brings the tile into the correct position and allows slight adjustment.

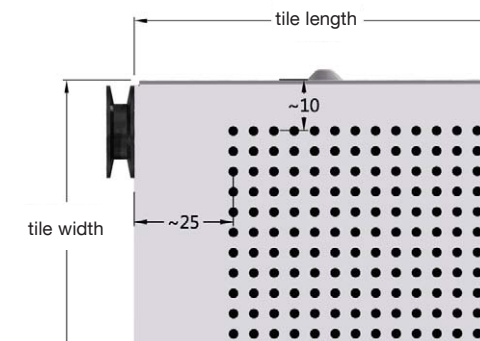
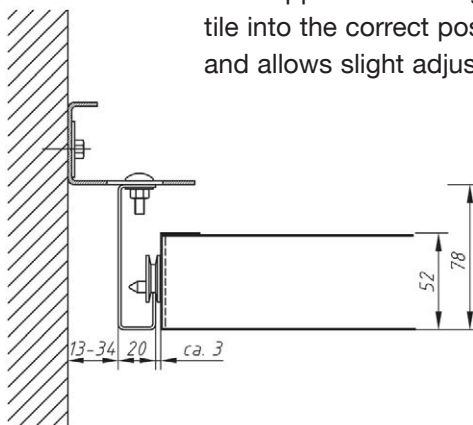

Swing out /
Sliding ceilings

FURAL® Acoustic Ceilings Long span tiles

frieze connection

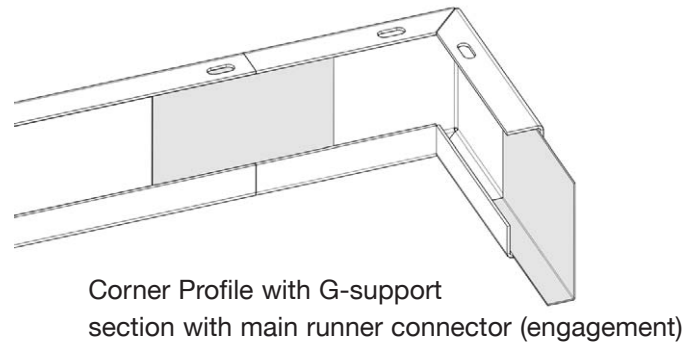
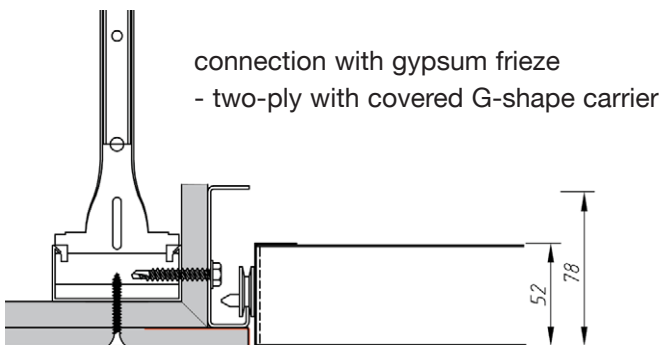
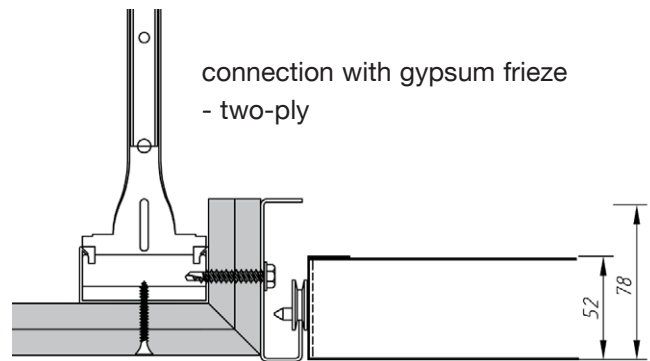
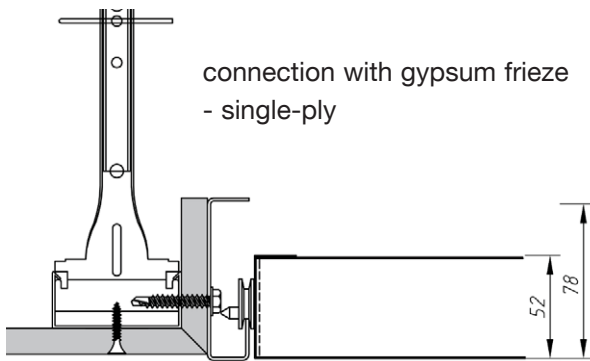

front connection

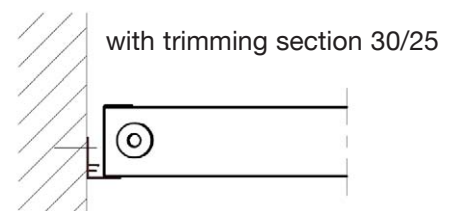
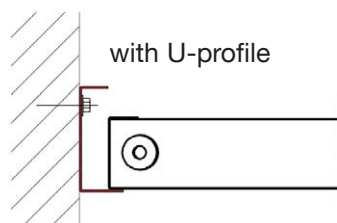
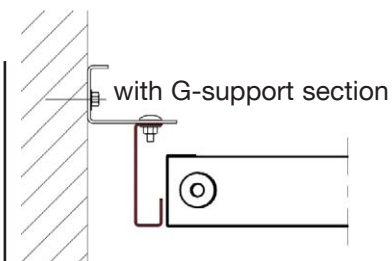

U-shaped edge bracket installation

Support spacing:

- According to respective system description
≤ 625 mm (page 64)

Fastening materials:

- Use only fasteners suitable for the type of substrate and, where appropriate, with the necessary building authority approval

Tools:

- Hammer drill (solid concrete), power drill
- Depending on rawl plug and bolt types, hammer and/or spanners

Installation procedure:

- Mark U-shaped edge bracket position on solid wall or plasterboard stud wall with a chalk line or laser and tape measure
- Drill hole and insert rawl plug, fasten wall angle with bolt in rawl plug

G-shaped supporting profile installation

- Screw G-shaped supporting profile to U-shaped edge bracket using M6 x 16 mm mushroom head bolt, M6 nut and M8 washer
- Adjustable shadow gap of approx. 13 – 34 mm
- First align and secure one side of the corridor
- Then align the second side parallel to the tile length + approx. 6 mm -> Setting gauge available from FURAL
- For corridor end faces, see variants on page 66

Tile installation

- Unpack and install the tiles - always wear ceiling installer gloves when working in order to avoid soiling
- Hook in the tiles in folded condition using the roller in the G-shaped supporting profile
- Fold up the tile and align the end joints, ensuring that the tiles do not interlock at the corners – install precisely corner to corner
- For the cut tiles at the corridor ends, measure the distance from the edge of the tile to the front edge of the edge profile and add + 15 mm for the support - this is the cutting dimension
- Cut the tile to size using an electric nibbler or sheet metal shears

Tile removal

- Fold down the tiles and unhook the roller diagonally, see also fire protection ceiling manual F30/EI 30.

Information

For variants of the different ceiling systems, see system descriptions in the ceiling manual. Please also note the information regarding the requirements of EN 13964 relating to the CE standard marking on pages 76 – 77.



WALL CONNECTIONS



ADVANTAGES :

› **Extruded aluminium sections:**

- neat wall connection
- pleasant visual impression

› **Tiles can be cut as required on site:**

- short installation times
- low cost

› **Bevelling of section ends:**

- avoid the picture frame effect

› **Continuous notch for nails:**

- permits convenient and fast installation

› **Fixing springs for securing:**

- neat visual impression of the edges

› **Suitable mitre joints available:**

- neat corner connection

› **Curtain rail:**

› **Curtain lifting aid incorporated by the manufacturer:**

- convenient installation

› **Trimming section connection at both sides:**

- convenient installation

› **A wide variety of ceiling connection options:**

- allows a high degree of freedom of interior design

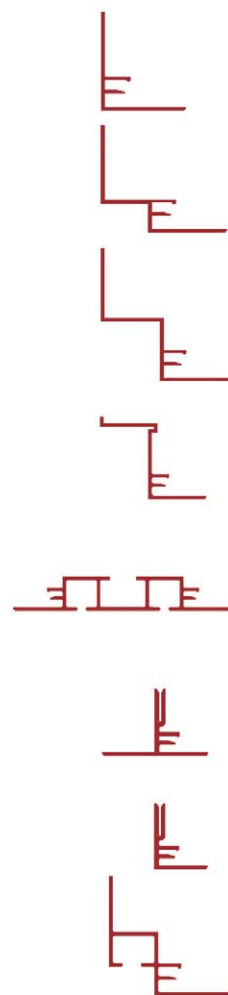

Versions:

Wall connections

Page:

70 - 71

Column rings

72 - 73

Curtain rails

74

Light shaft cladding

75

Dimensions and information for installation

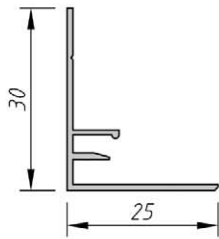

Trimming section
30/25

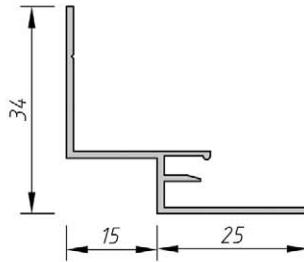

Shadow trimming section
15/10

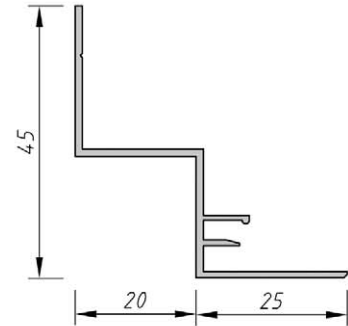

Shadow trimming section
20/20

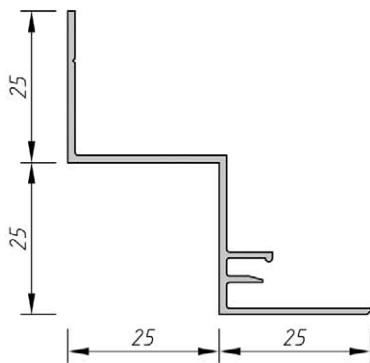

Shadow trimming section
25/25

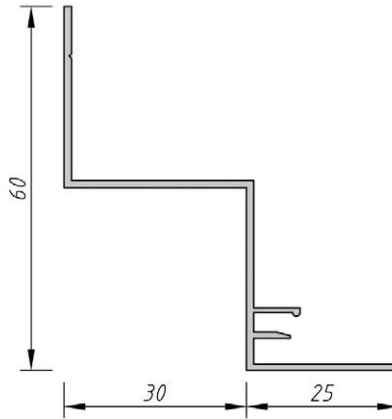

Shadow trimming section
30/30

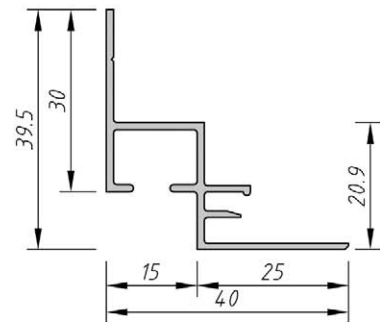

Picture rail
15/10

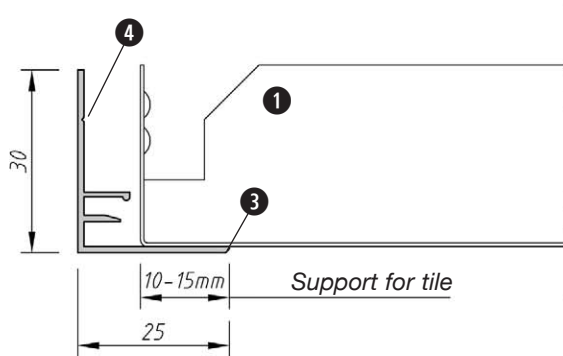

Support for entire tile

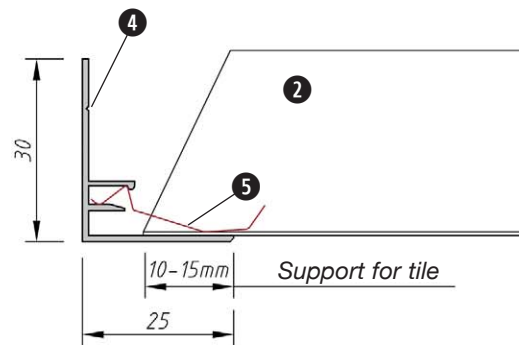

Support for sectioned tile

Dimensions and information for installation

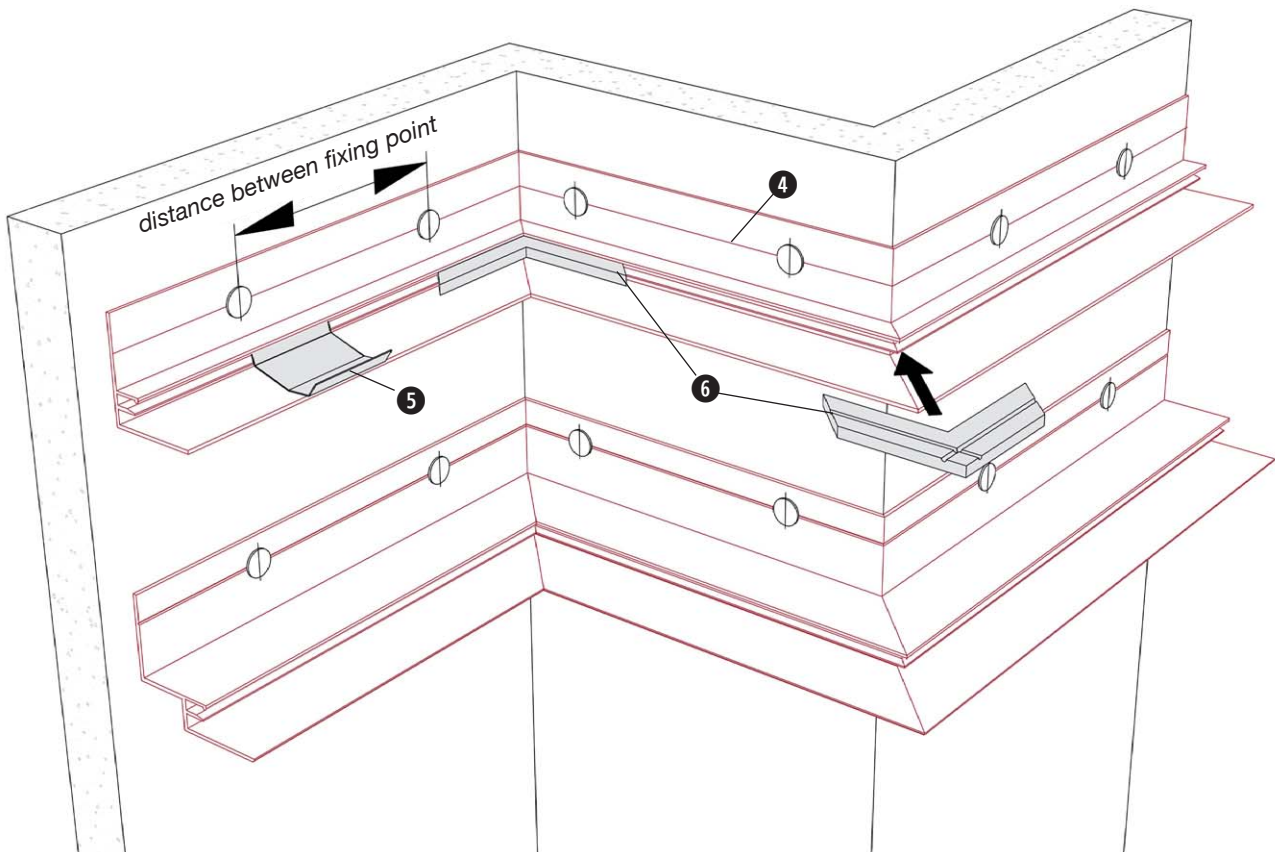

- › **FURAL** trimming sections are made of extruded aluminium sections coated in the colour of the ceiling. Standard colour RAL 9010. Delivery length: 4 m
- › 4 fixing springs per 625/625 tile correspond to approximately 6 fixing springs per metre of trimming section.

Distance between fixing points when mounted on support

- › 625 mm: Trimming section 30/25
Shadow trimming section 15/10 and 20/20
- › 400 mm: Shadow trimming section 25/25 and 30/30
Picture rail 15/10

- | | |
|---|--|
| ① | Entire tile |
| ② | Sectioned tile |
| ③ | Bevel to avoid the picture frame effect |
| ④ | Continuous notch for the recognition of the nail |
| ⑤ | Fixing springs (only where necessary) |
| ⑥ | Mitre joint |

Outside ring for columns

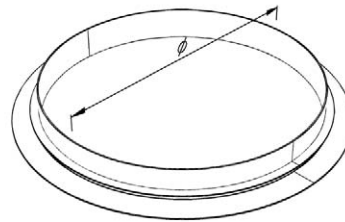
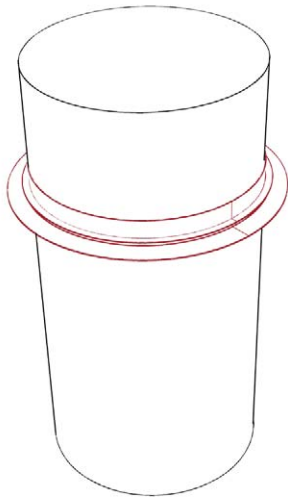

minimum radius

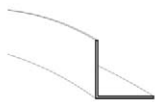

without spring ————— 150 mm

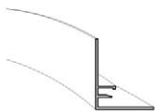

with spring ————— 150 mm

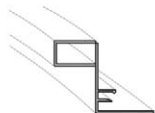

with spring ————— 250 mm

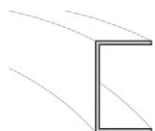

with U-section ————— 150 mm

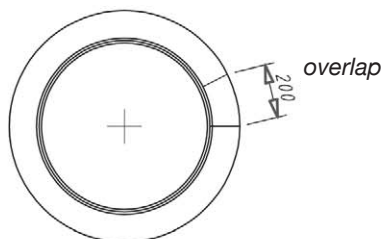

Complete ring

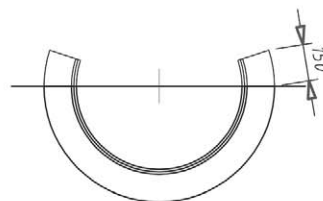

Half ring

Curved wall connection (inside)

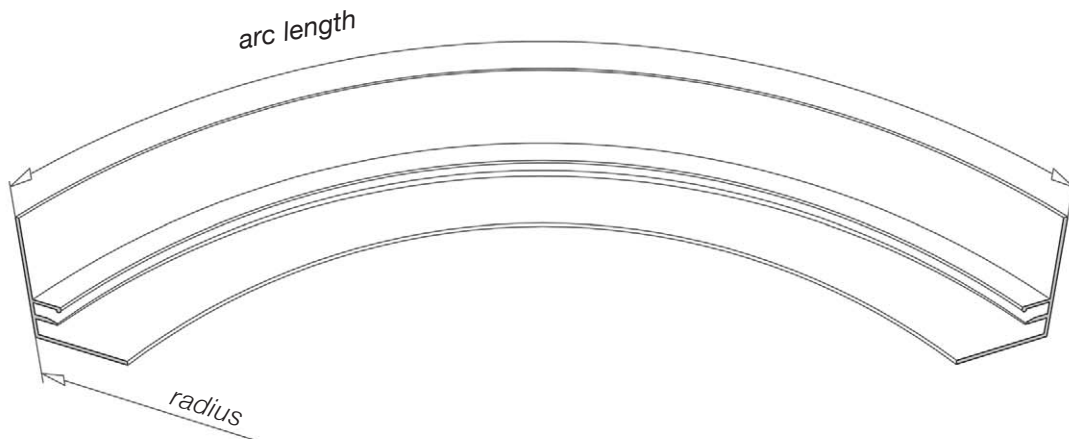

minimum radius

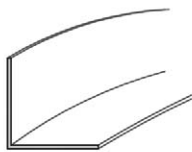

without spring ————— 400 mm

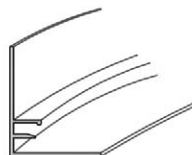

with spring ————— 2,000 mm

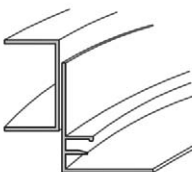

with spring ————— 2,000 mm

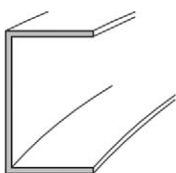

with U-section ————— 500 mm

Wall curtain rail

FURAL® Acoustic Ceilings 2-way curtain rail by FURAL

Design and information for application

FURAL curtain rails are made out of precision extruded aluminium sections, and are kept in stock in 4 m lengths. Same surface finish as ceiling tiles. Standard: RAL 9010

- ① **FURAL**-curtain rail, 2-way with lifting aid
- ② FVS shadow section
- ③ Suspension bracket
- ④ Wall fastening bracket
- ⑤ FVS section for frieze mounting
- ⑥ Screw M6 x 12 mm
- ⑦ Fixing spring

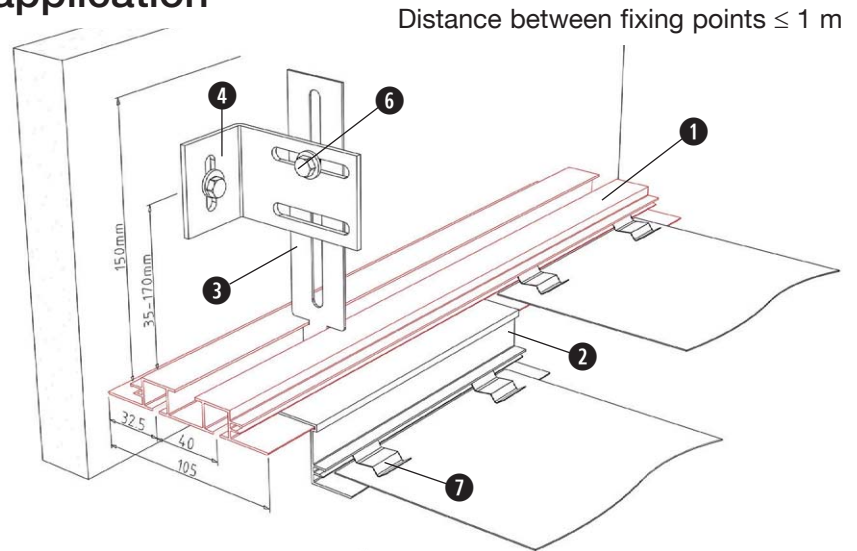

Mounting onto sections by use of springs

Lifting aids are incorporated by the manufacturer

level

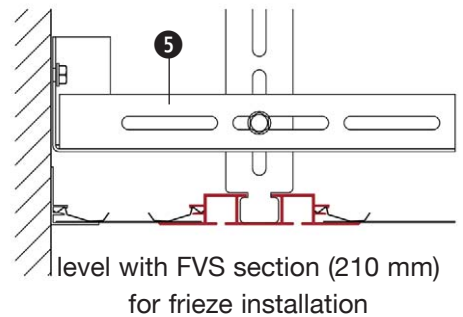
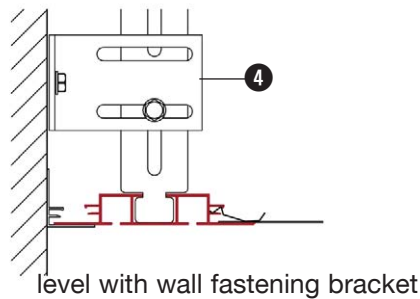
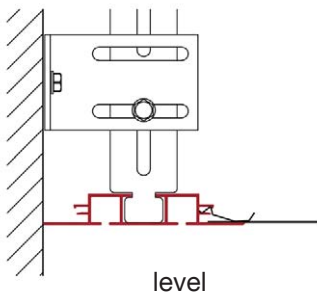

sunken

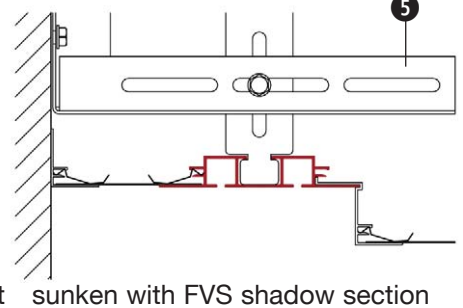
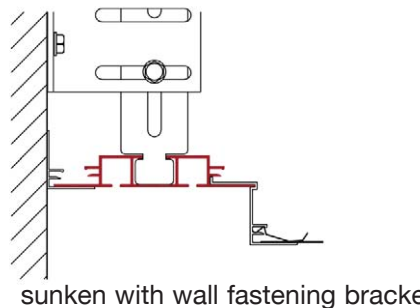
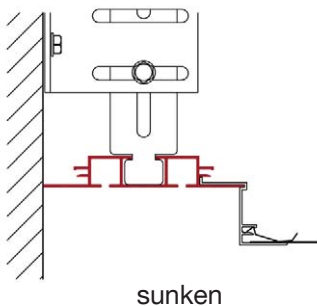

FURAL

with or without lower cover

Light shaft enclosures

Pre-fabricated, coated metal aprons according to actual field dimensions with lower enclosure made out of the light shaft section. (Extruded section).

One-sided with trimming section connection.

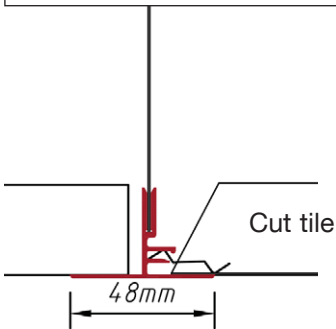
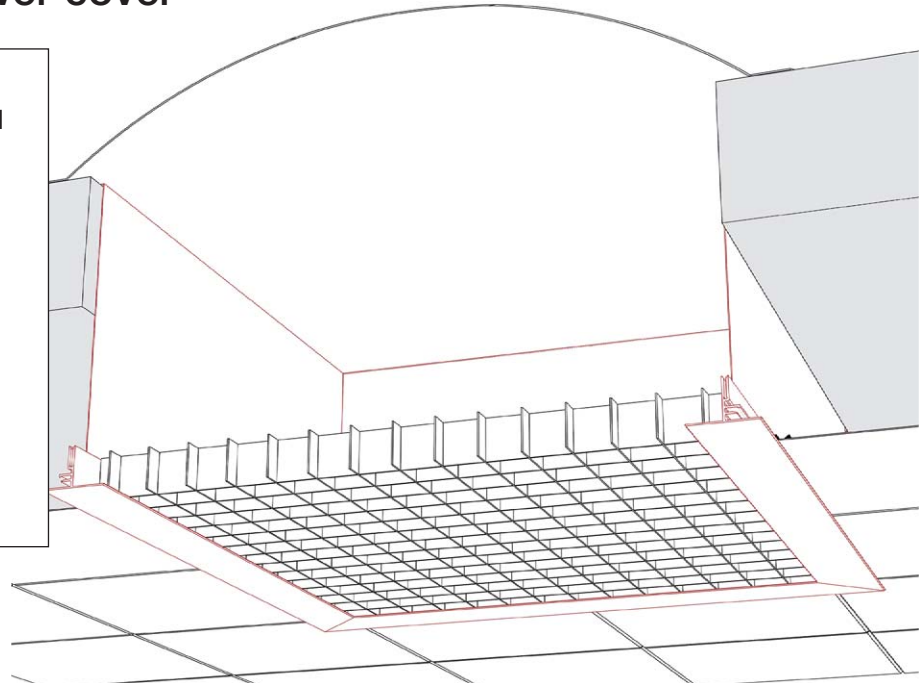

Light dome cover according to specification or open

- Grid
- Plexi glass (perspex)
- Glass

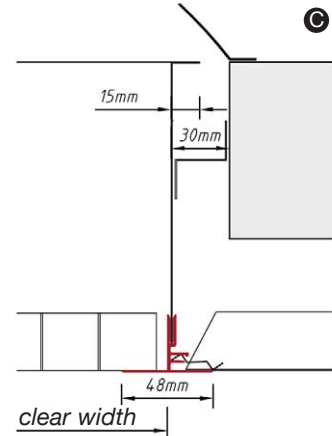
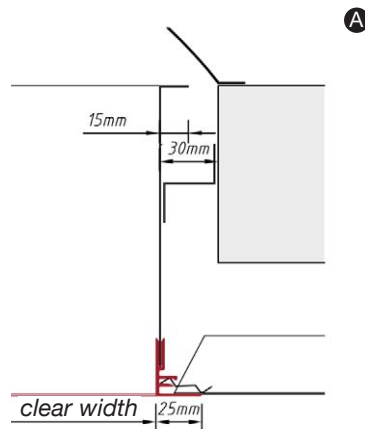

A + B

Light shaft cladding without cover and apron connection profile

C + D

Light shaft cladding with cover

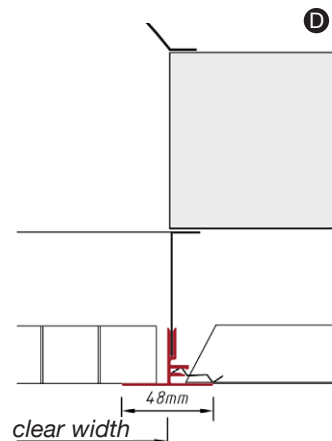
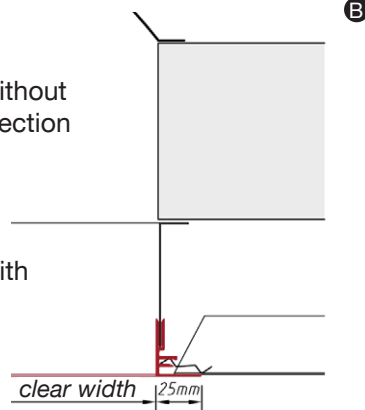

4.3 Mechanical strength and stability of supporting elements

4.3.2 Substructure

The substructure of suspended metal ceilings (suspended ceilings) normally consists of the anchoring of the suspension elements in the substrate (e.g. raw ceiling), the suspension elements and their fasteners, and the system supporting profiles and their connectors. All structural components have been tested in combination and the classification corresponds solely to their joint use in the system. As there are many possible fasteners, the choice can only be made by the company conducting the installation.

The type and number of anchoring elements and edge profile fasteners are defined for each system in the ceiling manual. Observance of these specifications ensures that the load-bearing capacity of the fastener is not exceeded. Always ensure that the fastener selected is suitable for the base material of the supporting structure (raw ceiling/wall) in order to comply with the **requirements of Annex B** of EN 13964.

As there are many options beyond the sphere of influence of the manufacturer, the choice can only be made by the company conducting the installation. We recommend only using components whose suitability is certified by a European Technical Approval (ETA). If such approval is not available, the specifications in Annex B of EN 13964 must be observed. Please contact **FURAL** for any further information or advice. As the manufacturer, however, we can only accept responsibility solely for the components supplied, not however, for the overall responsibility for the installed system.

4.3.2.1. Load-bearing capacity – see also section 5

The load-bearing capacity of the substructure is verified by testing both of each individual component and of components in combination. All system supporting profiles have been tested in accordance with EN 13964 and conform to Class 1 in Table 6.

Due to the large number of possible profile spacings (tile lengths) and for optimum use of the system, the relevant values must be taken from the respective system diagrams.

If further additional loads need to be borne, the planner must be notified accordingly. Only then can a special validation, differing from the standard, be carried out. This can then be performed in accordance with the requirements of the standard (assuming that the costs are met).

4.3.4 Resistance to fasteners

The substructure components and covering layer components are designed for the inherent load-bearing capacity without additional loads. No additional punctual or areal load can be borne without further evaluation.

4.3.5 Resistance to wind loads (special ceiling area)

The installing company is responsible for securing covering layers inside the building in areas where suction or pressure loads due to wind pressures (e.g. near doors and windows) can be expected using suitable components. If the planner requires a wind-proof design, this must be specified on ordering, together with an indication of the wind loads.

4.3.6 Impact resistance

See ceiling manual, page 10 and 11 or 18 and 19.

4.3.7 Resistance to seismic effects

If suspended ceilings will be exposed to seismic vibration, this must be indicated separately by the planner.

4.4 Safety in the event of fire

4.4.2 Fire classification

The fire classification has been verified in accordance with

EN 13501-1 and certified by classification reports from „MPA Stuttgart“ (Notified Body No. 0672).

4.5 Hygiene, health and environment – toxic gases and hazardous substances

4.5.1 Release of asbestos (content)

Metal components do not contain asbestos and are therefore marked with „No asbestos content“. Any additional substances, such as coating materials, acoustic inlays, etc. are also free from asbestos.

4.5.2 Release of formaldehyde and/or formaldehyde content

All components of the metal ceiling are free from formaldehyde and are therefore assigned to Class E1. Note: The requirements of the standard still apply as the standard is also applicable to wood and wood materials.

4.5.3 Other hazardous substances

The manufacturer declares that no substances have been used in manufacturing the metal ceilings which cause hazardous emissions, so no initial test is required. Furthermore, substructure components and covering layers have been tested for compliance with the reference values for volatile organic compounds (VOC) according to the assessment system of the German Committee for Health-Related Evaluation of Building Products (AgBB).

4.5.4 Susceptibility to the growth of micro-organisms hazardous to health

When used for their intended purpose, the metallic materials employed are not susceptible to the growth of micro-organisms and are therefore assigned to Class A according to Table 7.

4.6 Safety of use

4.6.1 Splinter resistance

Metal covering layers are not subject to the requirement for determining the behaviour in the event of splintering or breakage. Consequently, the „NPD“ (no performance determined) option is used and no initial test was conducted.

4.6.2 Bending tensile strength

The classification indicated applies to the basic variant of the covering layer without additional weight or openings and is determined on a test specimen representative of the covering layer material under consideration of the span length.

The allowance for deflection of the substructure component stipulated in Table 6 has been neglected, because this is of negligible significance for the method used for fastening metal ceilings. The standard prescribes that the load class according to Table 8 is also specified under this item. If further additional loads need to be borne, the planner must be notified accordingly. Only then can a special validation, differing from the standard, be carried out. This can then be performed in accordance with the requirements of the standard (assuming that the costs are met).

4.6.4 Electrical safety

The requirements of the CENELEC HD 384 standards are so extensive that the manufacturer of the suspended ceiling cannot accept responsibility for comprehensive observance. It is the duty of the planner to draw attention to any requirements in this context and of the installation company to observe these accordingly.

If electric cables are routed through visible or concealed ducts connected to the substructure of the ceiling, this must be indicated accordingly by the planner for structural reasons.

If the suspended ceiling needs to be earthed, this must be conducted by a licensed specialist company in accordance with national standards. If any modifications to the suspended ceiling are required for this purpose, then this must be indicated separately by the respective planner.

4.7 Acoustics

4.7.2 Sound absorption

See ceiling manual, pages 112 to 114.

4.7.3 Sound insulation

See separate documents.

4.8 Durability

4.8.2 Moisture

The thermal insulation and dew point calculations required by the standard cannot be performed by the manufacturer, as none of the necessary information is available and this requirement would extend far beyond the manufacturer's sphere of activity. The manufacturer takes the view that these calculations and any necessary measures derived from them must be performed by the planner. Any additional corrosion protection required according to Table 8 would, in this context, have to be indicated by the planner.

4.8.3 Service life

Depending on how the room is used and the conditions therein, cleaning for visual reasons is recommended at pre-determined intervals. This is not required for functional reasons, in order to maintain fitness for use at any time throughout the entire service life.

Cleaning of visible surfaces, dry cleaning:

- Wipe clean with a dry, soft cleaning cloth
- Use a vacuum cleaner with soft brush attachment

Cleaning of visible surfaces, wet cleaning:

- Use commercially available, non-abrasive cleaning agents diluted with clean water -> the mixing ratio depends on the degree of soiling of the ceiling tiles; all common glass cleaning agents have proven to be effective
- Use special cleaning agents (evaporative – e.g. diluted white spirit) for stubborn, greasy soiling.

Painting of the ceiling with commercially available paints is possible. It should be noted, however, that painting can be detrimental to the fire characteristics of the product. Furthermore, it is not advisable on perforated ceiling panels, because this impairs the acoustic properties. Also note that ugly cracks may occur in the joint area.

4.8.4 Classification of the loading conditions for the suspended ceiling and

4.8.5 Corrosion protection

Ceiling panels: In the standard version, these are made from sheet steel with continuous hot-dip surface finish Z100 to EN 10346, thereby assuring the corrosion protection required in Table 8 for Class B according to Table 7. Substructure parts in the standard variant are made of sheet steel with a hot-dip galvanised surface of at least Z100 to EN 10346 or higher, thereby assuring the corrosion protection required for load class B.

Special materials: If components are made from other materials, the minimum corrosion protection is provided according to Table 8, depending on the required load class.

4.8.6 Protection from contact corrosion

If the design or load class indicates that contact corrosion can occur between different materials, this must be pointed out by the planner. Suitable protection measures can then be taken in accordance with EN ISO 12944-3, section 5.10. Depending on the application, the coating must be applied to at least the more precious metal, or to both metals.

4.9 Colour, light reflection and gloss factor for suspended ceiling components

The substructure components and covering layer components provided with a decorative coating (powder coating,

PARZIFAL hydro stove enamelling) in the visible area have the order-specific colour (e.g. RAL or NCS).

In standard cases (RAL 9010, smooth), light reflection value R is approx. 80-85% and is determined according to ISO 7724-2 and ISO 7724-3. In standard cases (RAL 9010), the gloss factor measured at an angle of 60° is approx. 20%, by PARZIFAL hydro stove enamelling at approx. 10% and is determined according to EN ISO 2813.

4.10 Thermal insulation

If thermal insulation is required, this must be indicated separately by the planner. The planner must also draw attention to measures required to prevent the formation of condensation. On request, proof of this is furnished in accordance with EN ISO 6946 and EN ISO 10211-1 on the basis of reference design values to EN 12524 by an approved testing institute (assuming that the costs are met).

5.0 Load-bearing capacity of the substructure components – test methods

5.1 General

Test methods have been applied for metal substructures and suspension and connecting elements if their load-bearing capacity could not be calculated. The components to be tested were tested both individually and in combination as they are used in practice. A safety factor of 2.5 was observed.

5.2 Bending test of metal substructure profiles

Primary and secondary profiles:

The deflection of the primary and secondary profiles of each system was tested by testing institute "ITB - INSTITUT FÜR BAUTECHNIK" (Notified Body No. 1488) on behalf of FURAL or its profile suppliers. Deflection class 1 to Table 6 was taken as the basis for the specification. Consequently, the suspension element spacings of the supporting rails have been defined for the dead weight of the ceiling including substructure, but without additional load. In view of the large number of options, reference is made on the product label to the specifications and diagrams in the ceiling manual and/or to the **performance declaration** instead of the classification.

Edge bracket profiles:

The deflection of the edge bracket profiles was also tested by the testing institute.

5.3 Testing of the metal suspension and connecting elements

All substructure components were tested individually and in combination as they are used in practice. This allowed the weakest point of a system to be determined. We strongly recommend that only such parts intended for a particular system are used. An incorrect combination of substructure parts can result in the system collapsing.

The numbering refers to the list in EN 13964 and is explained here in excerpts.



DETAILS / ACCESSORIES

ADVANTAGES :

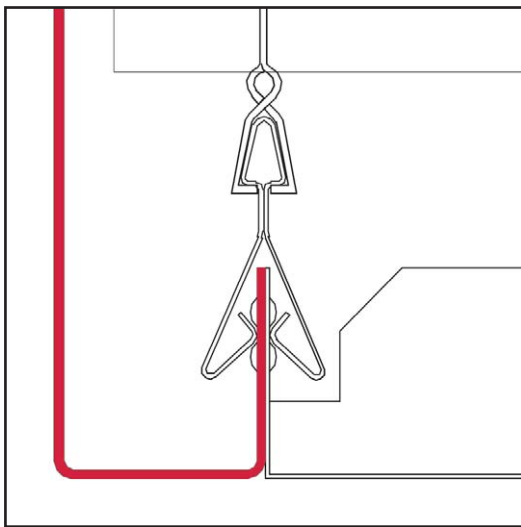

› Aprons – clean solutions:

- Various designs for each individual case
- For level differences between ceilings and ceiling connection

› Installation of light fittings – many possibilities:

- Installation of light fittings in tile format
- Tiles with factory-made cutouts for recessed light fixtures
- Support structure for light fittings

Clip-in system:

	Page:
Aprons	80 - 81
Inspection doors	82
Installation of light fittings (in square- and long span tiles)	84 - 91

Hang-in system:

Aprons	92
Installation of light fittings	93

for clip-in system

U-shaped apron

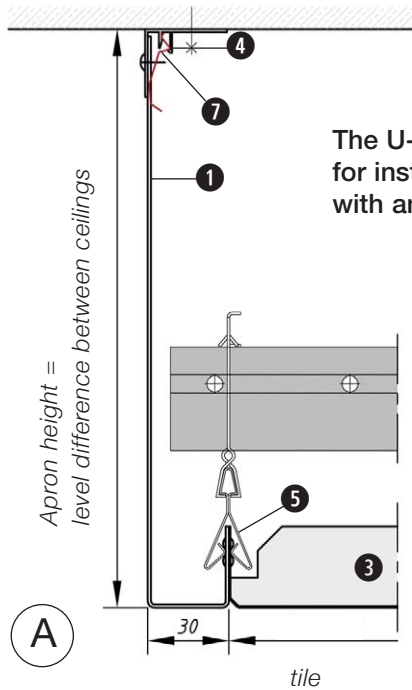

The U-shaped apron:
for installation start
with an entire tile!

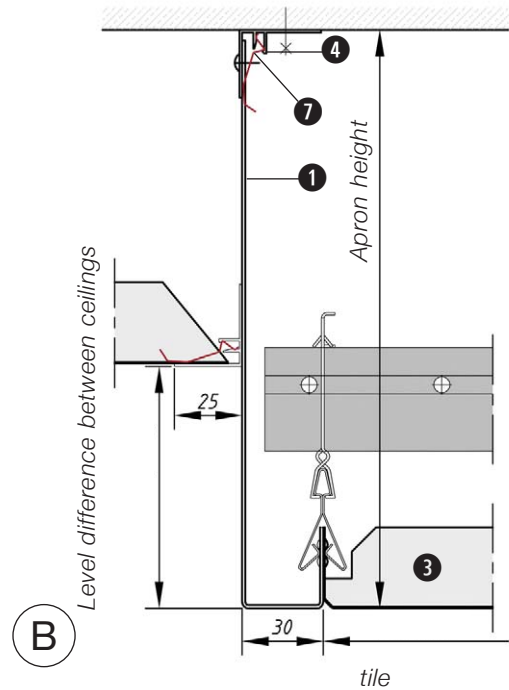

with trimming section

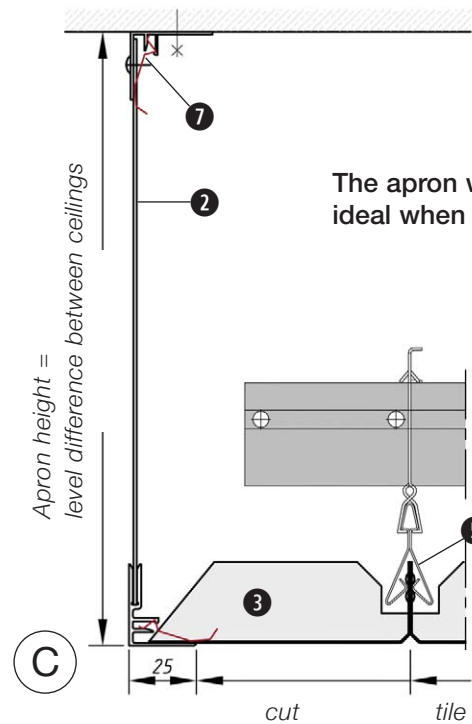

The apron with trimming section:
ideal when using cut-off tiles

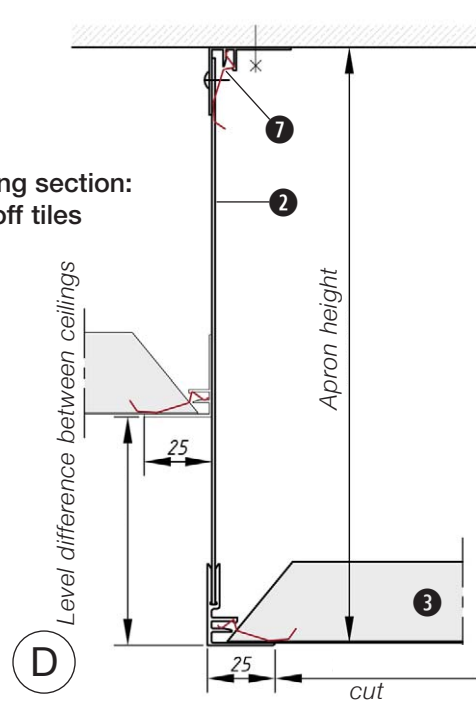

- ① Apron with U-shaped end
- ② Apron with trimming section (alu)
- ③ Tile
- ④ Trimming section
- ⑤ Clipping rail
- ⑥ Suspension element
- ⑦ Fixing springs

for clip-in system

E

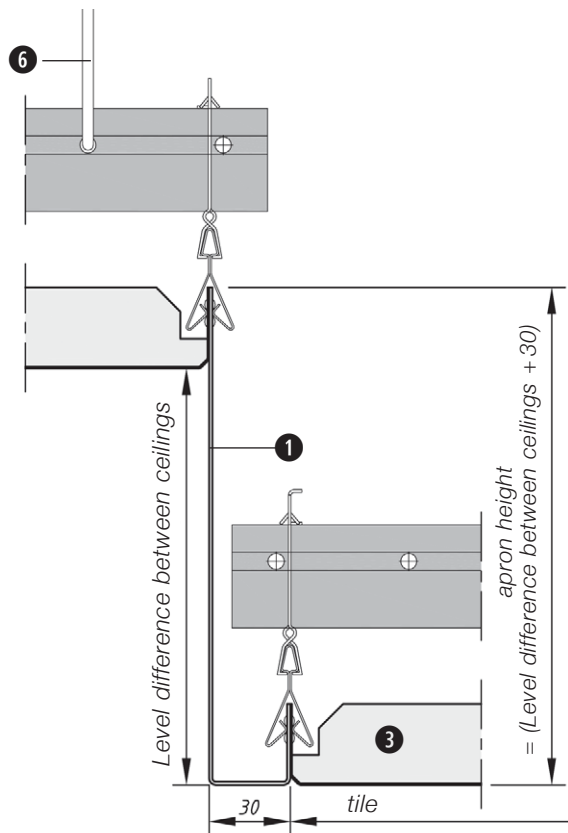

F

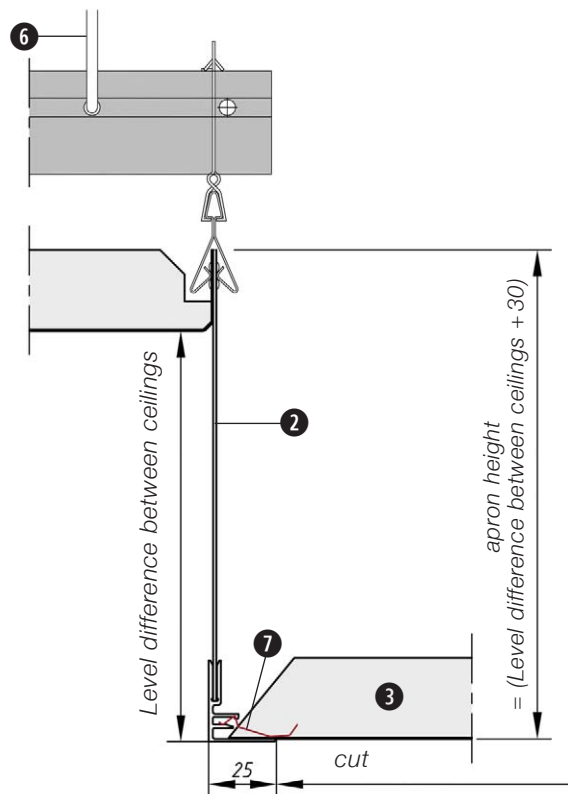

U-shaped apron

with trimming section

for clip-in system

KQK 625/625

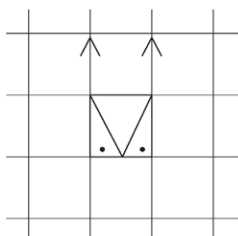

- ① Twist lock
- ② Fixing plate
- ③ Hinge mounting
- ④ Allen key 4 mm
- ⑤ Special-shackle

Format: 625x625 mm / 600x600 mm
Other dimensions on request

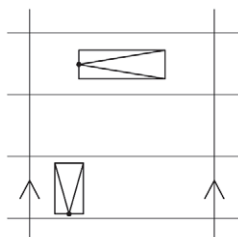
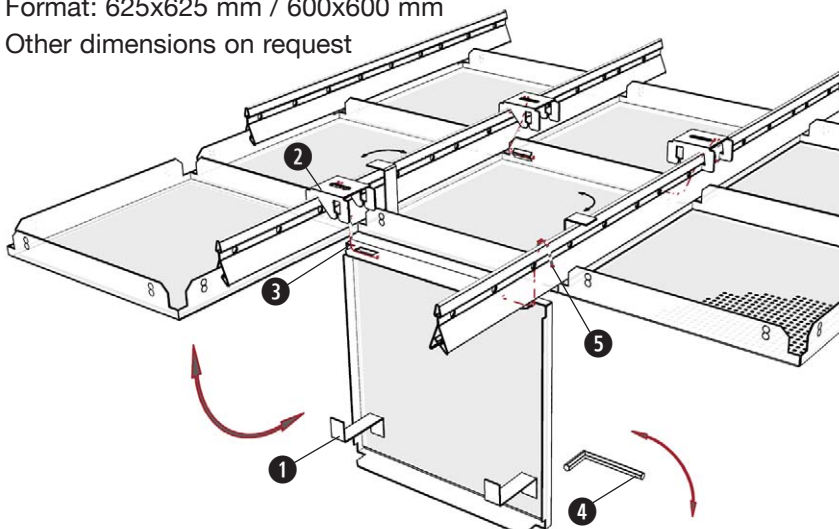

- ① Inspection door
- ② Twist lock
- ③ Frame
- ④ Tile

For frequent access to specific locations in
the inter-ceiling space.

Format: 300/500 mm
(Special formats upon enquiry)

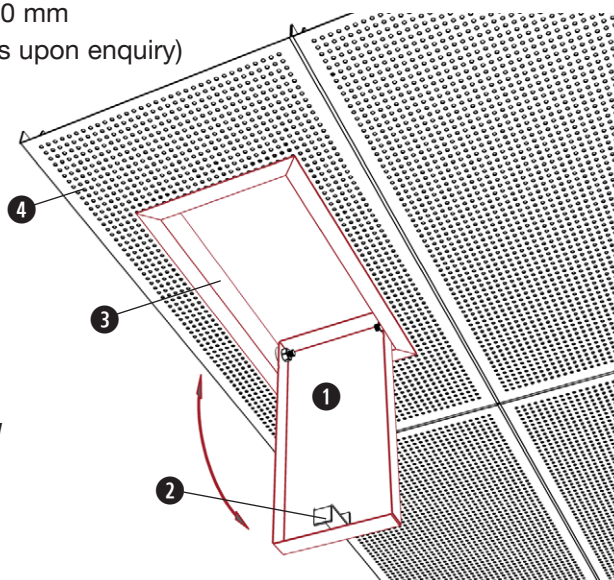

*Also suitable for post-installation
in long span tiles.
Position and opening direction as required
in the specific location. Universally usable.*

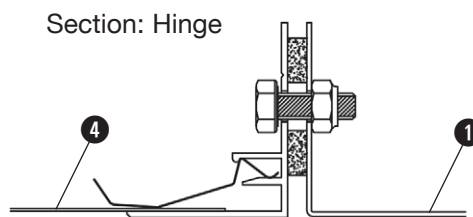
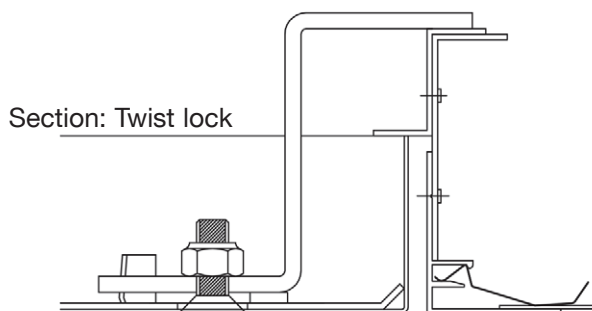

for long span tiles



FURAL® Acoustic Ceilings
Installation of light fittings –
square light fitting

for clip-in system – square tiles

- Ⓐ Light fitting
- Ⓑ Fastening bracket (set)*
- Ⓒ Clipping rail used as grid rail
- Ⓓ Ceiling suspension

* Fastening bracket (set) always supplied with the light fitting

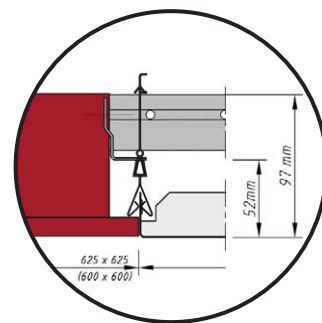
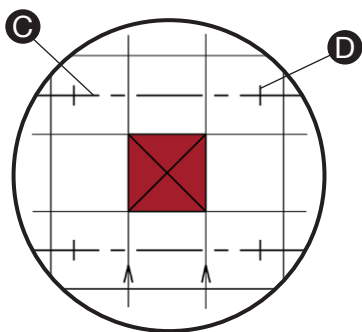
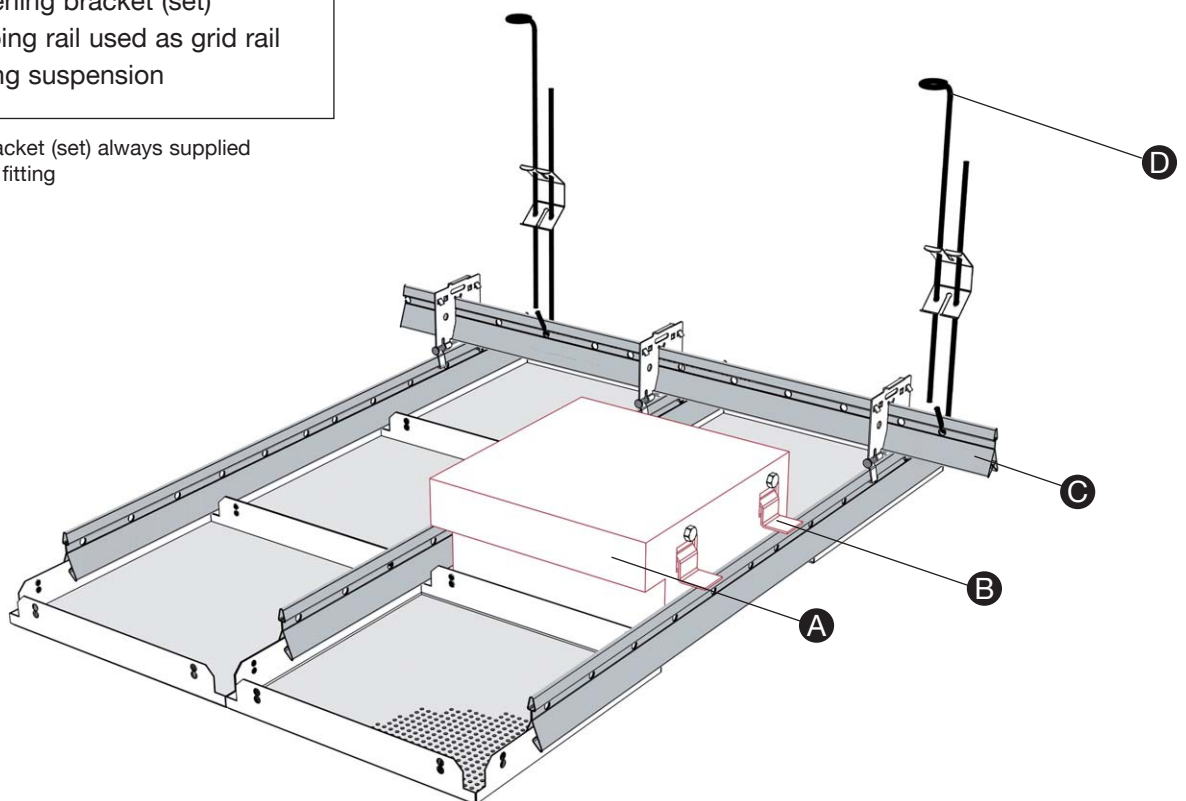

Installation of light fitting

- Light fitting Ⓐ in module 625/625 or 600/600 mm
- Install fastening bracket Ⓑ
- Place the light fittings on the clipping rails.
- Light fitting must be suspended separately (not shown).
- Safeguard against falling, in accordance to lighting manufacturer's installation instructions.

FURAL® Acoustic Ceilings
**Installation of light fittings –
 rectangular light fitting in supporting tile**

for clip-in system – square tiles

- A** Light fitting
- B** Supporting tile with cut-out (including bent edge)
- C** Clipping rail used as grid rail

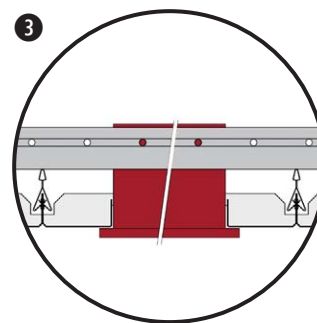
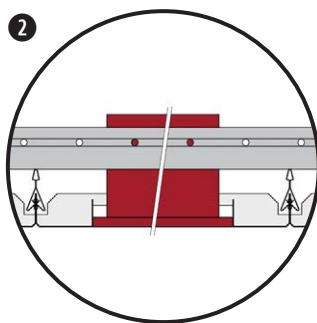
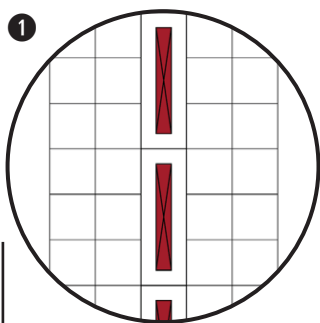
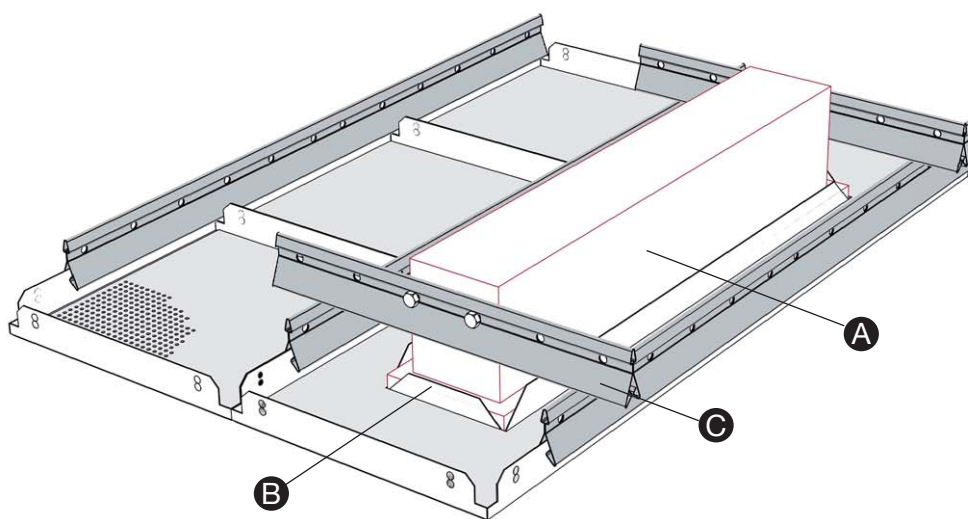

- 1** Light fitting in supporting tile
- 2** Light fitting frame flush with ceiling
- 3** Projecting fitting frame

Installation of light fitting

- Mount clipping rail **C** (2 units per light fitting)
- Place the light fittings on the clipping rails.
- Light fitting must be suspended separately (not shown).
- Safeguard against falling, in accordance to lighting manufacturer's installation instructions.

FURAL® Acoustic Ceilings Installation of light fittings – rectangular light fitting - row of light fitting

for clip-in system – square tiles

- A** Light fitting
- B** Fastening bracket (set)*
- C** Clipping rail used as grid rail
- D** Ceiling suspension
- E** Suspension key wire

* Fastening bracket (set) always supplied with the light fitting

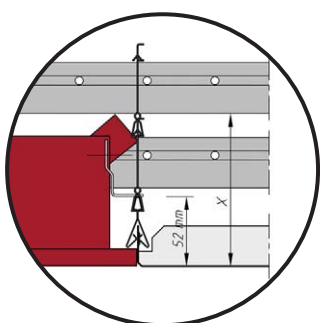
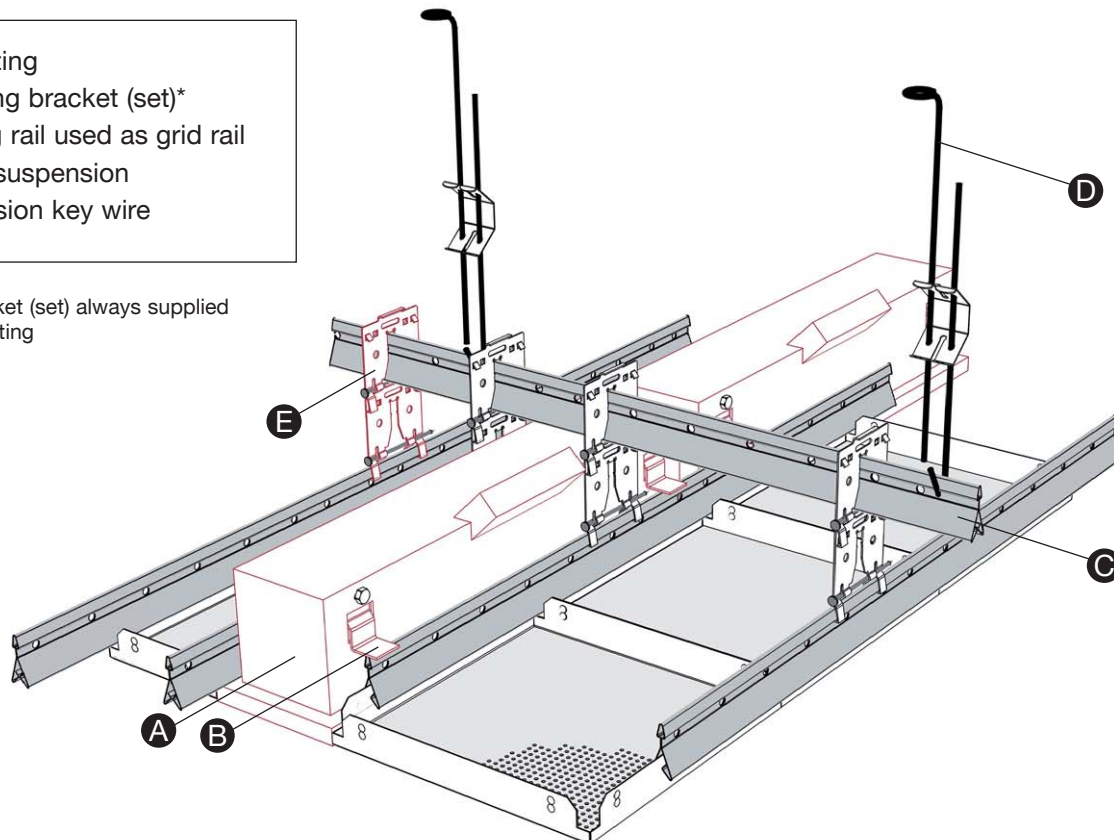

1

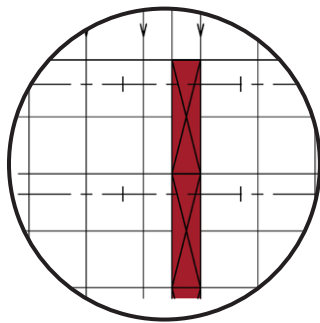

2

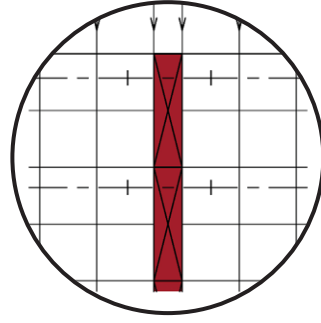

3

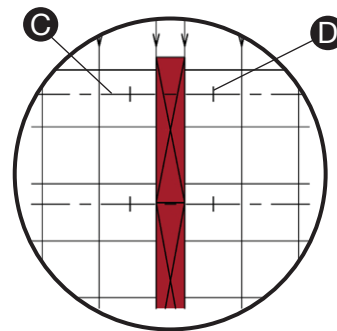

4

Installation of a Row of Light Fittings

- Grid rail running above the lighting box through dimension (x):
 - with 2 suspension keys = 113 mm
 - with 3 suspension keys = 167 mm
 - with 4 suspension keys = 221 mm
- Mounting fastening bracket **B**
- Place the light fittings on the clipping rails.
- Light fitting must be suspended separately (not shown).
- Safeguard against falling, in accordance to lighting manufacturer's installation instructions.

- 1 Section: Light fitting / grid profile
- 2 Light fitting L = 1,250 mm
- 3 Light fitting L = 1,250 mm
- 4 Light fitting L = 1,550 mm

Details Accessories

FURAL® Acoustic Ceilings Installation of light fittings – single rectangular light fitting

for clip-in system – square tiles

- Ⓐ Light fitting 312/1,250, 184/1,250 or 300/1,200
- Ⓑ Fastening bracket (set)*
- Ⓒ Clipping rail used as grid rail
- Ⓓ Ceiling suspension wire

* Fastening bracket (set) always supplied with the light fitting

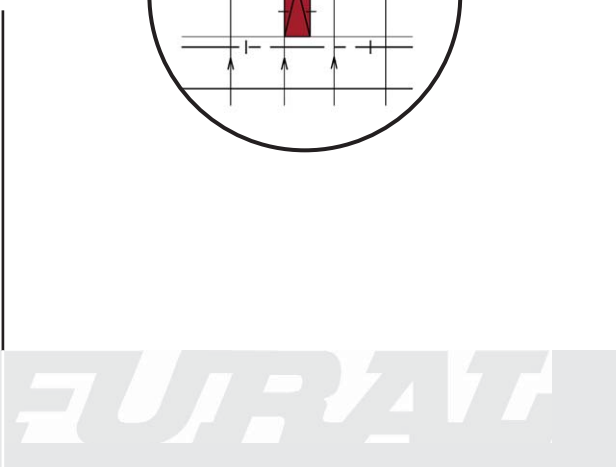
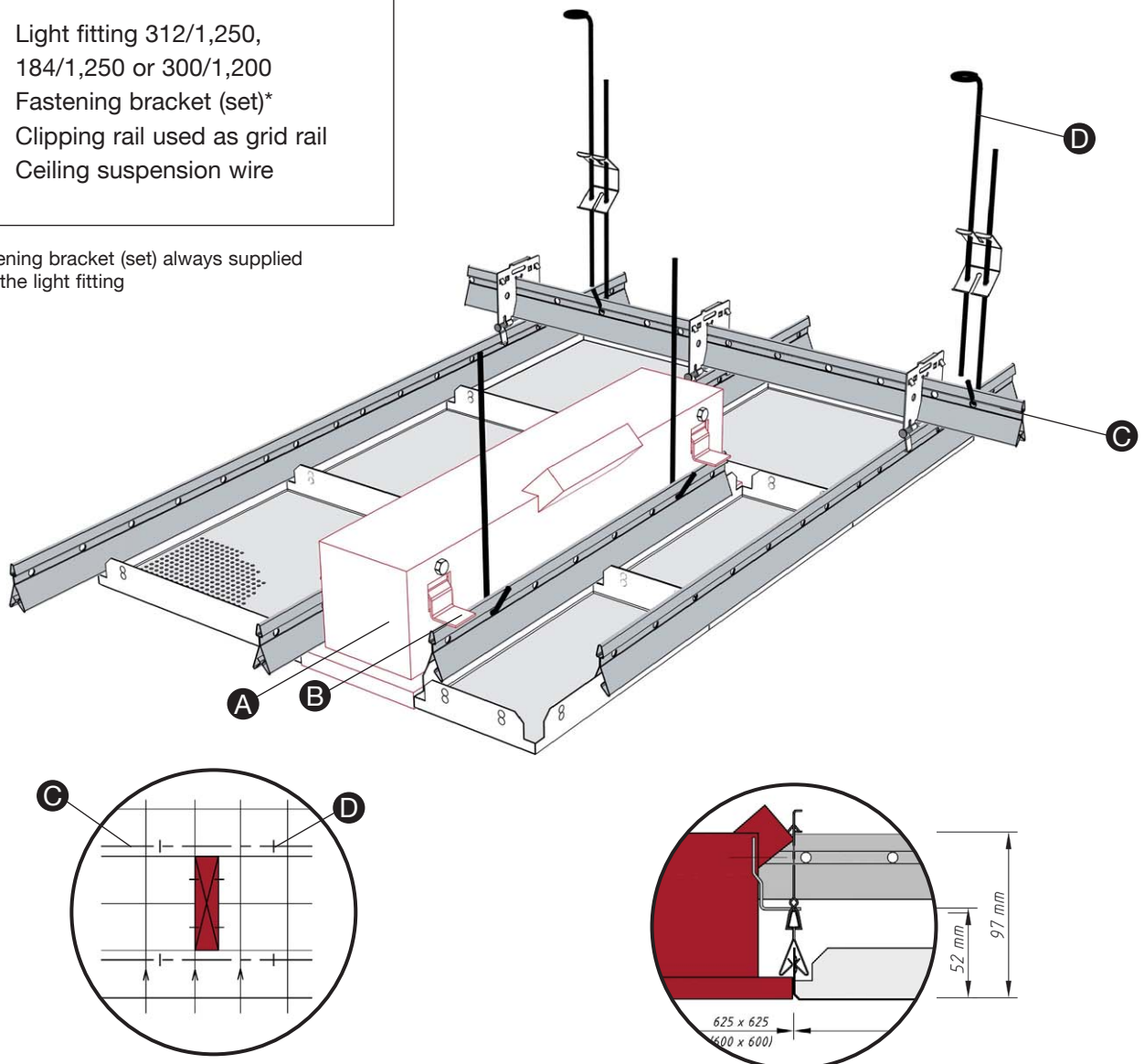

Installation of light fitting:

- Mount fastening bracket Ⓑ
- In addition, install one piece of clipping rail (L 1,230)
- Place the light fittings Ⓐ on clipping rails.
- Light fitting must be suspended separately (not shown).
- Safeguard against falling, in accordance to lighting manufacturer's installation instructions.

FURAL® Acoustic Ceilings
**Installation of light fittings -
rectangular light fitting in supporting tile**

for clip-in system – long span tiles

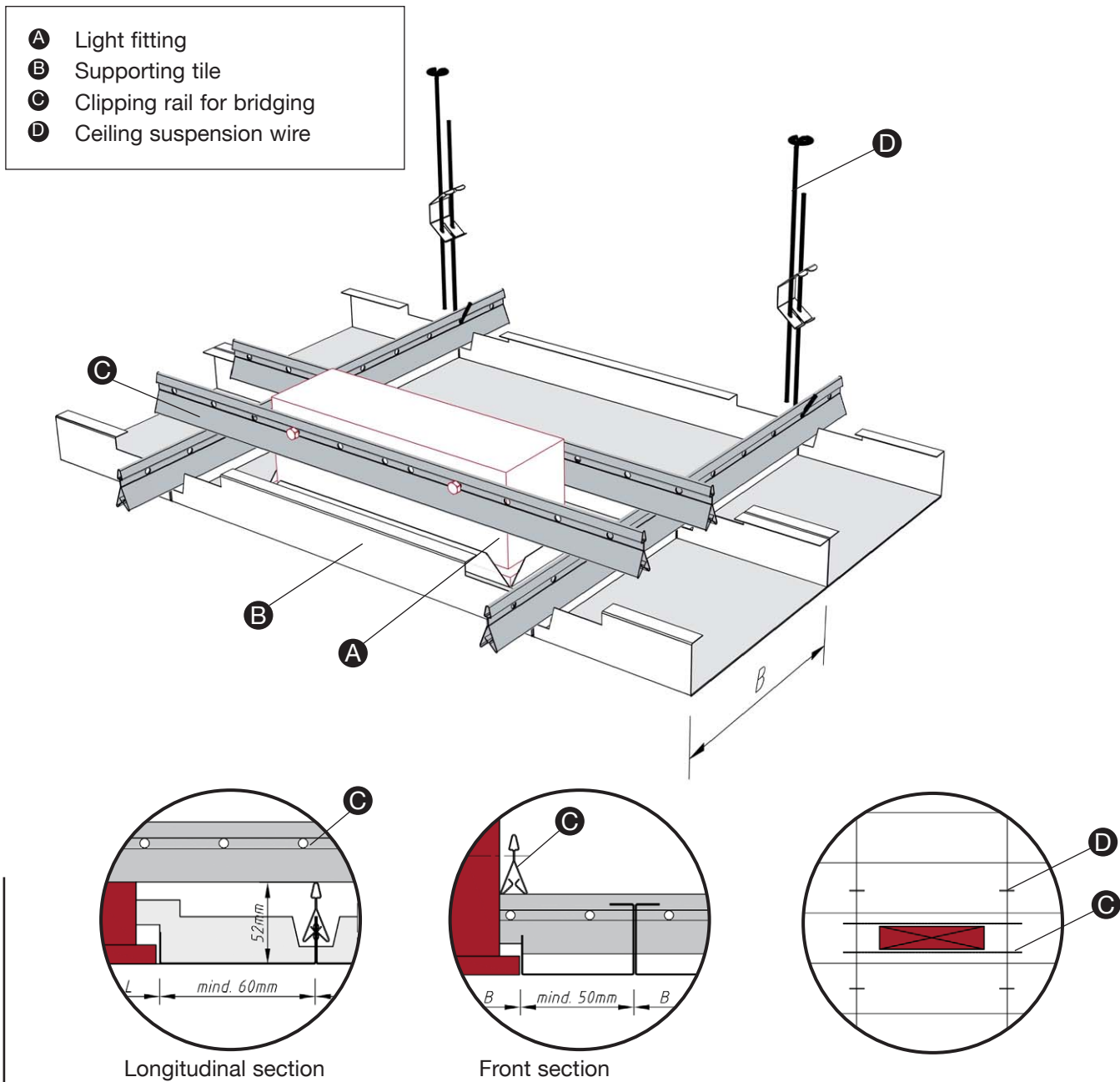

Installation of light fitting:

- Bolt 2 pieces of clipping rail onto the long sides of the light fitting.
- Place the light fittings on the clipping rails.
- Light fitting must be suspended separately (not shown).
- Safeguard against falling, in accordance to lighting manufacturer's installation instructions.

FURAL® Acoustic Ceilings
Installation of light fittings - rectangular
light - same width as a tile - with fitting tile

for clip-in system – long span tiles

- Ⓐ Light fitting
- Ⓑ Fitting tile
- Ⓒ Clipping rail for bridging
- Ⓓ Ceiling suspension wire

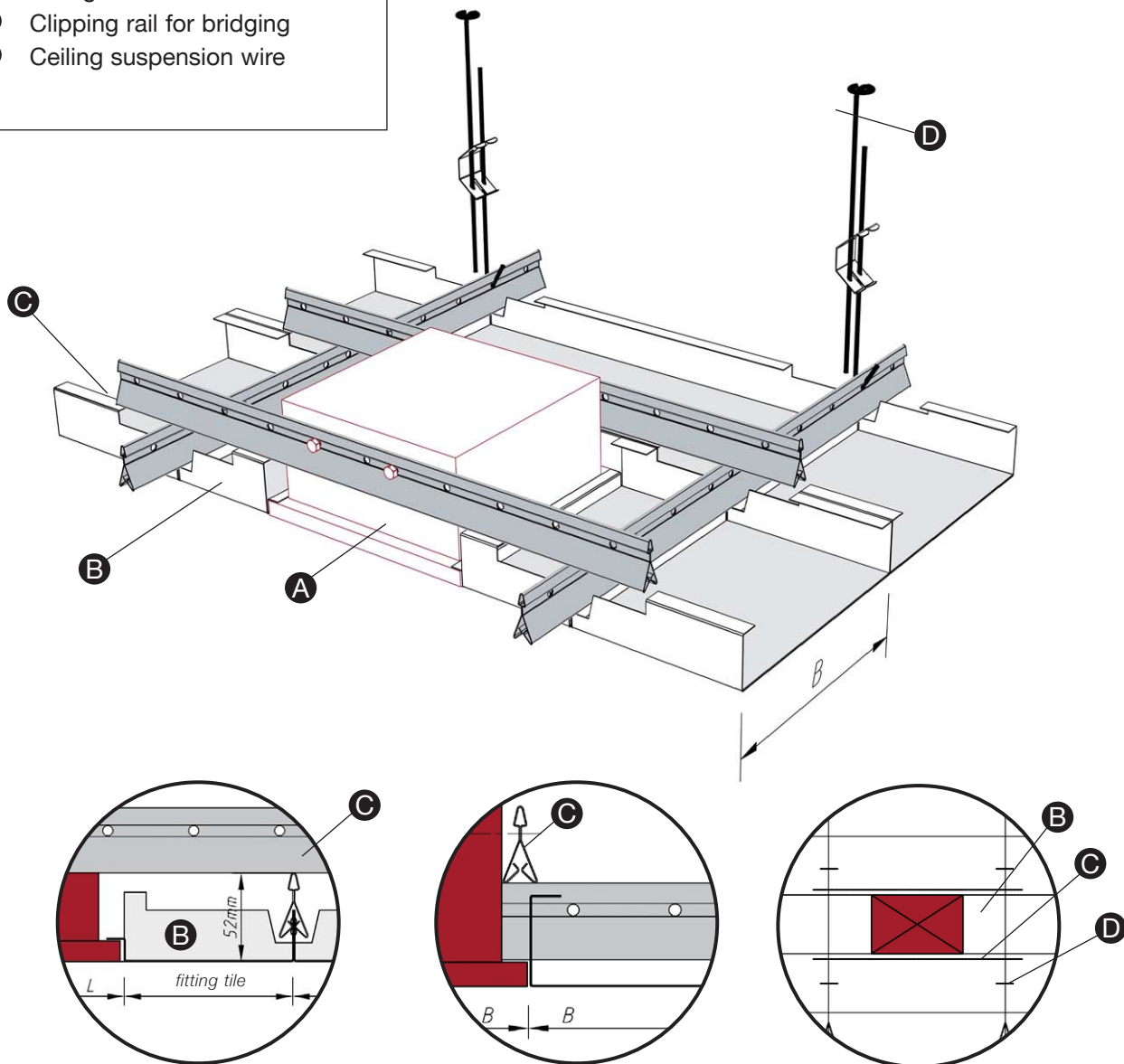

Installation of light fitting:

- Bolt 2 pieces of clipping rail on to the long sides of the light fitting.
- Place the light fittings on the clipping rails.
- Light fitting must be suspended separately (not shown).
- Safeguard against falling, in accordance to lighting manufacturer's installation instructions.

FURAL

FURAL® Acoustic Ceilings
Installation of light fittings -
rectangular light fitting - in tile format

for clip-in system – long span tiles

- Ⓐ Light fitting
- Ⓑ Fastening bracket (set)*
- Ⓒ Ceilings suspension wire

* Fastening bracket (set) always supplied with the light fitting

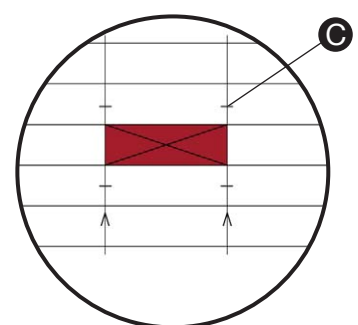
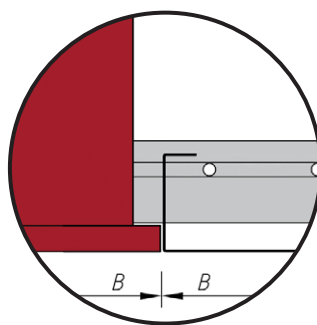
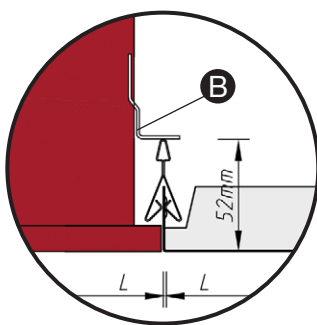
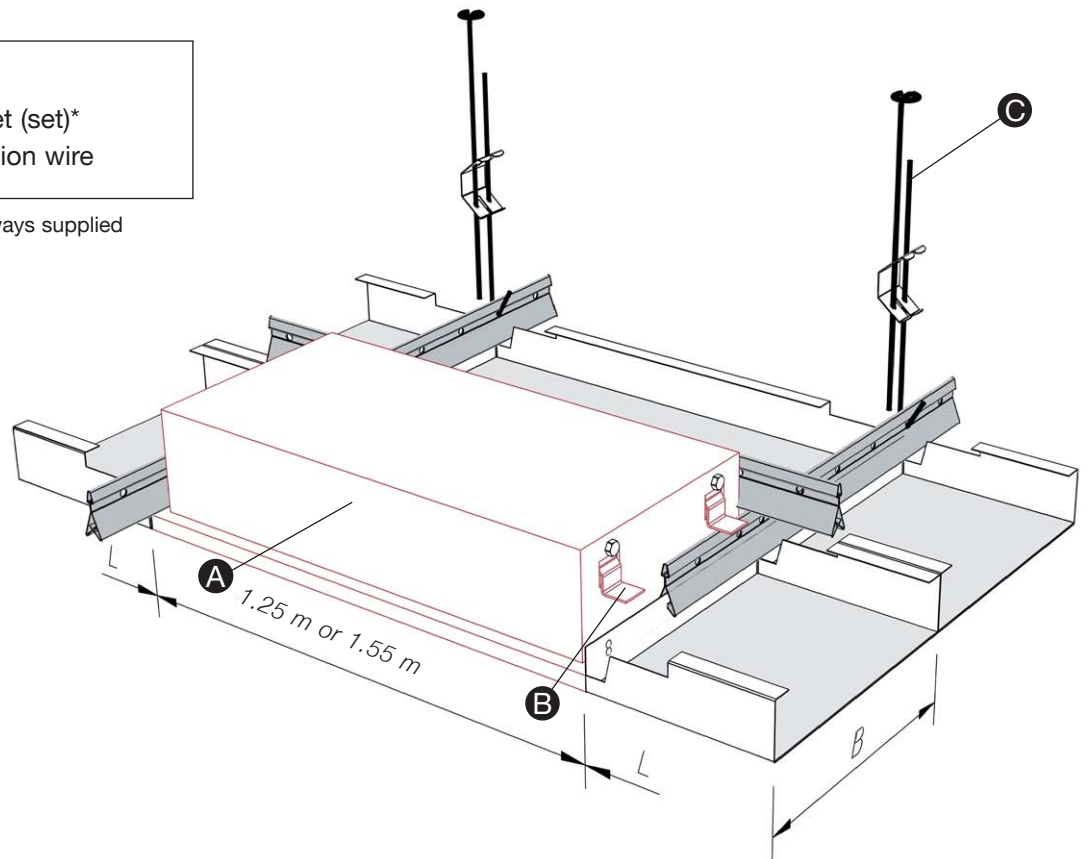

Installation of light fitting:

- Mount fastening bracket Ⓑ
- Place the light fittings on the clipping rails.
- Light fitting must be suspended separately (not shown).
- Safeguard against falling, in accordance to lighting manufacturer's installation instructions.

for clip-in system – square tiles

- Ⓐ Support structure for light fittings
Ⓑ Light fitting bridge for modules 625 and 600 mm

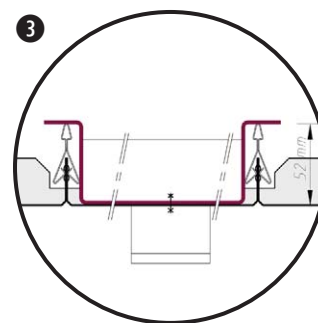
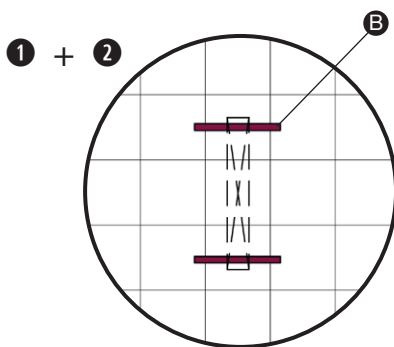
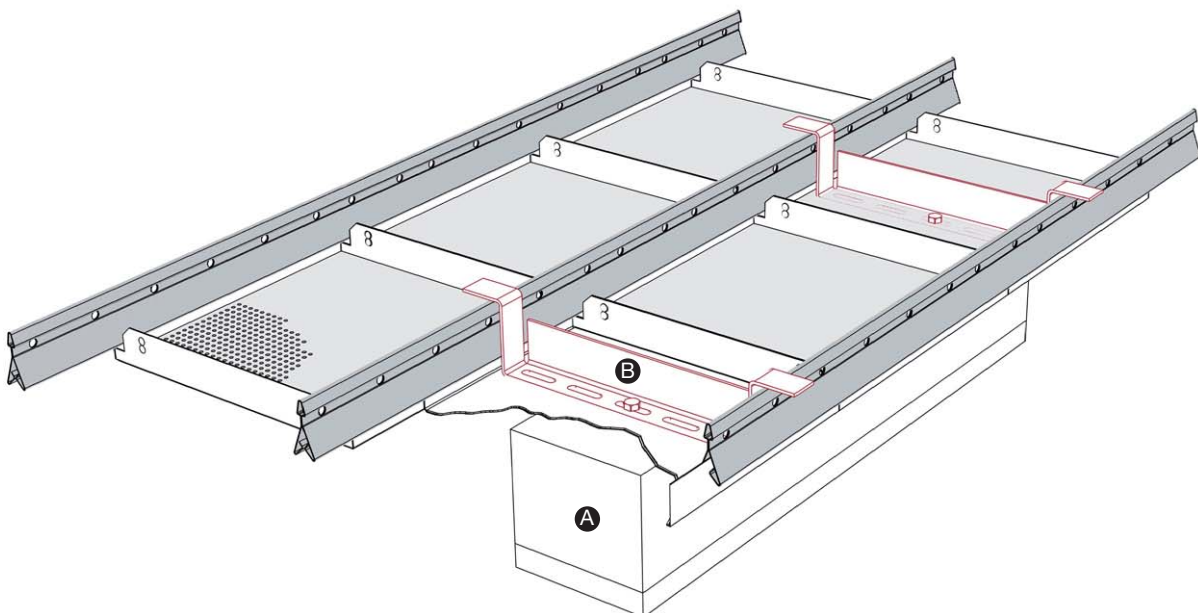

- ① Light fitting L = 1,250 mm
② Light fitting L = 1,550 mm
③ Light fitting bridge for modules 625 and 600 mm

Installation of light fitting:

- 2 bridges per light fitting.
- Bolt light fitting onto the bridges.
- Light fitting must be suspended separately (not shown).
- Safeguard against falling, in accordance to lighting manufacturer's installation instructions.

for hang-in system

U-shaped apron

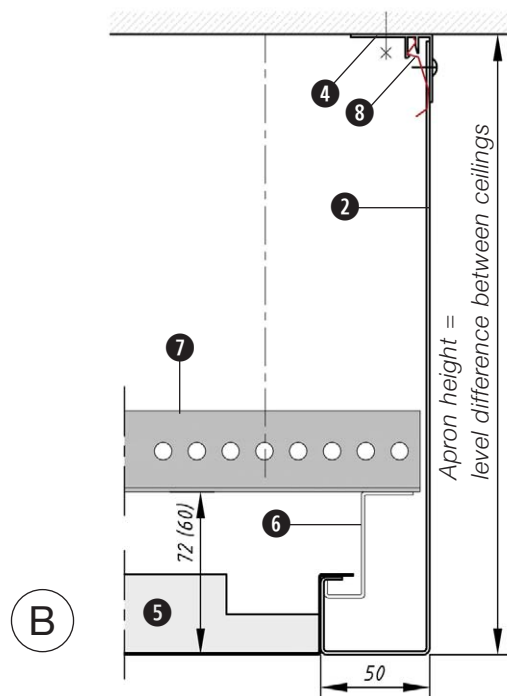
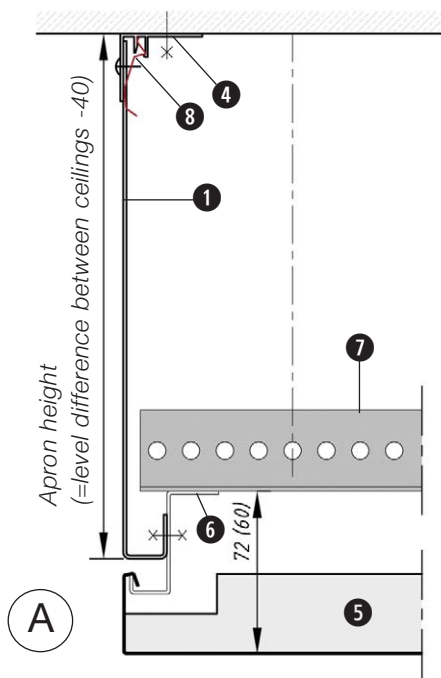

with trimming section

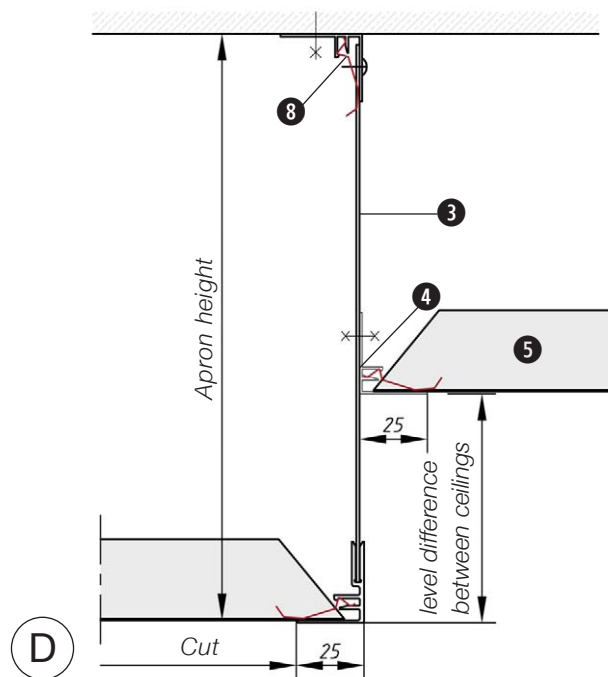
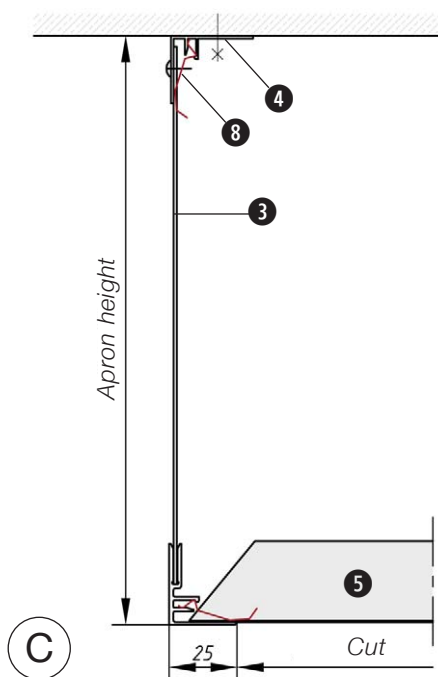

- | | |
|---------------------------------|----------------------|
| ① Apron with U-shaped end 16x16 | ⑤ Hang-in tile |
| ② Apron with U-shaped end 50x30 | ⑥ Hang-in Z rail |
| ③ Apron with trimming section | ⑦ Grid bracket 30/30 |
| ④ Trimming section | ⑧ Fixing springs |

FURAL® Acoustic Ceilings
**Installation of light fittings -
rectangular light fitting in supporting tile**

for hang-in system

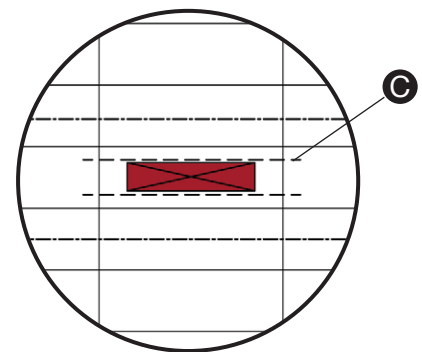
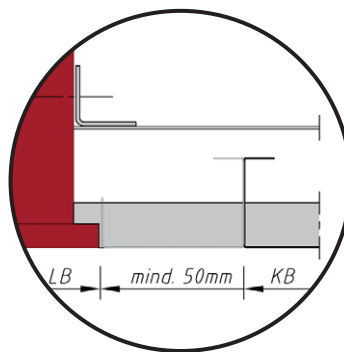
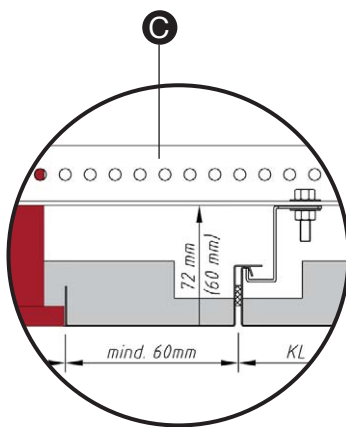
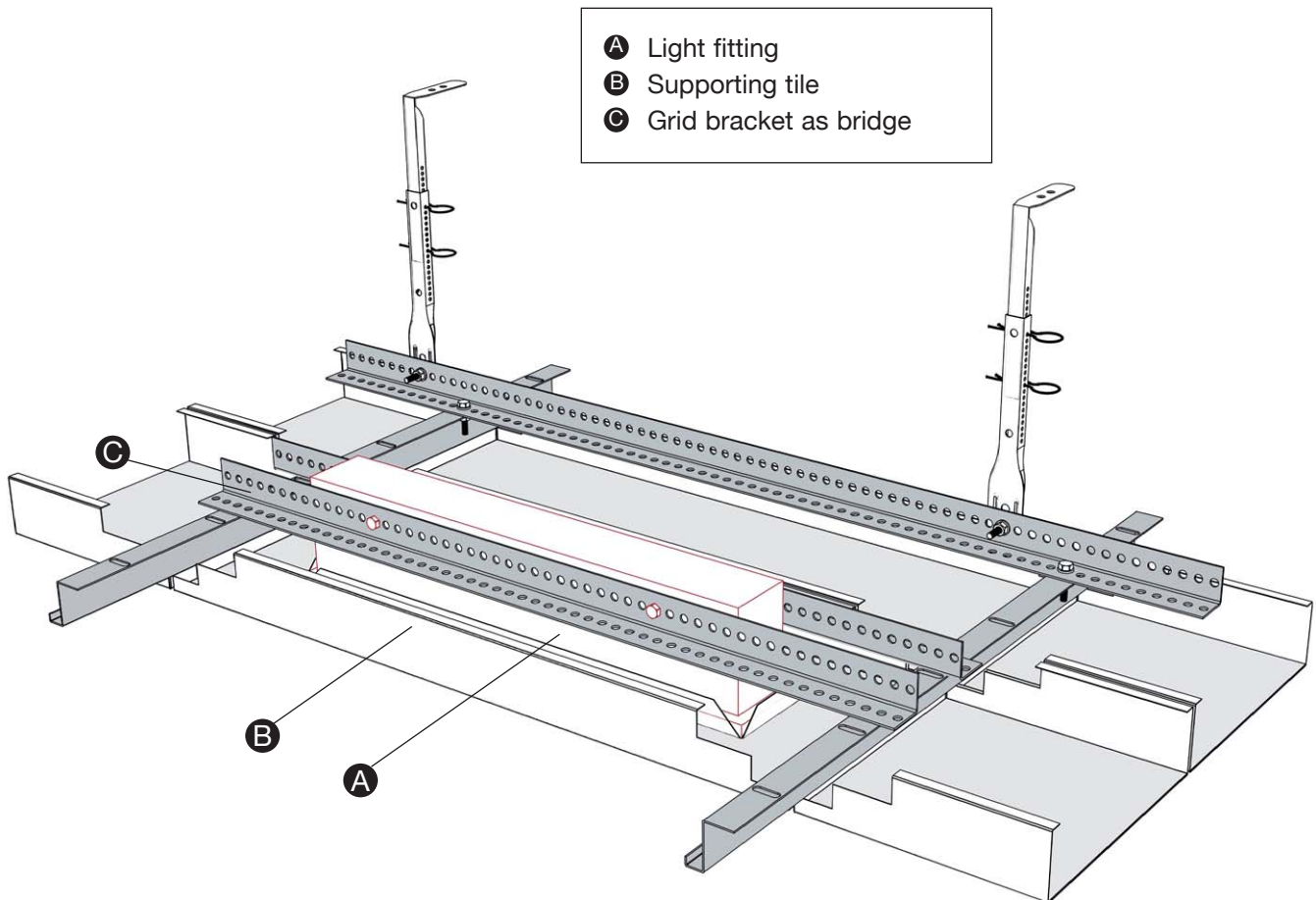

Installation of light fitting:

- Bolt 2 pieces of grid bracket 30/30 onto the long sides of the light fitting.
- Place the light fittings on the Z-shaped profile.
- Light fitting must be suspended separately (not shown).
- Safeguard against falling, in accordance to lighting manufacturer's installation instructions.



F&S

α
ACOUSTIC

H
HYGIENE

COOLING
CEILING

FUNCTIONS – & SPECIAL CEILINGINGS

ADVANTAGES :

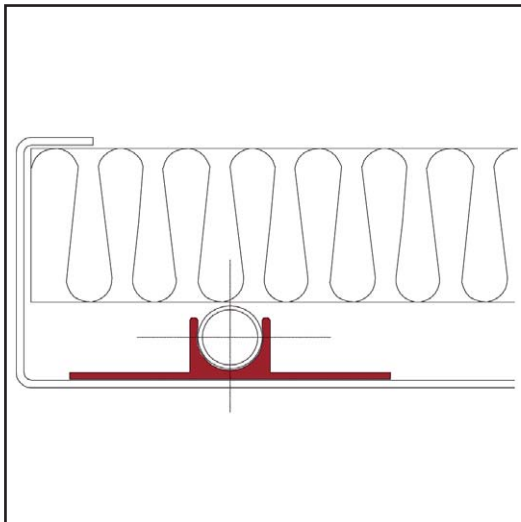

› Flexibility in room design

- Free arrangement of floating ceiling units
- Each ceiling „island“ equipped with complete technical systems

› Cost efficient:

- Ideal alignment with the spatial geometry
- Less disassembly work for accessibility to ceiling cavities, including cleanroom ceilings

› Functionality

- Special design depending on the requirements for acoustic, cooling, wind safety, etc.

Function/System:

Page:

Cleanroom ceiling	96 - 99
Cool ceiling	100 - 103
Floating	104 - 111
Stretch metal	115
Galaxy	115

KLK 1.2.3.4

FURAL® Acoustic Ceilings Long span tiles – clip-in system

Hygiene ceiling - corridor

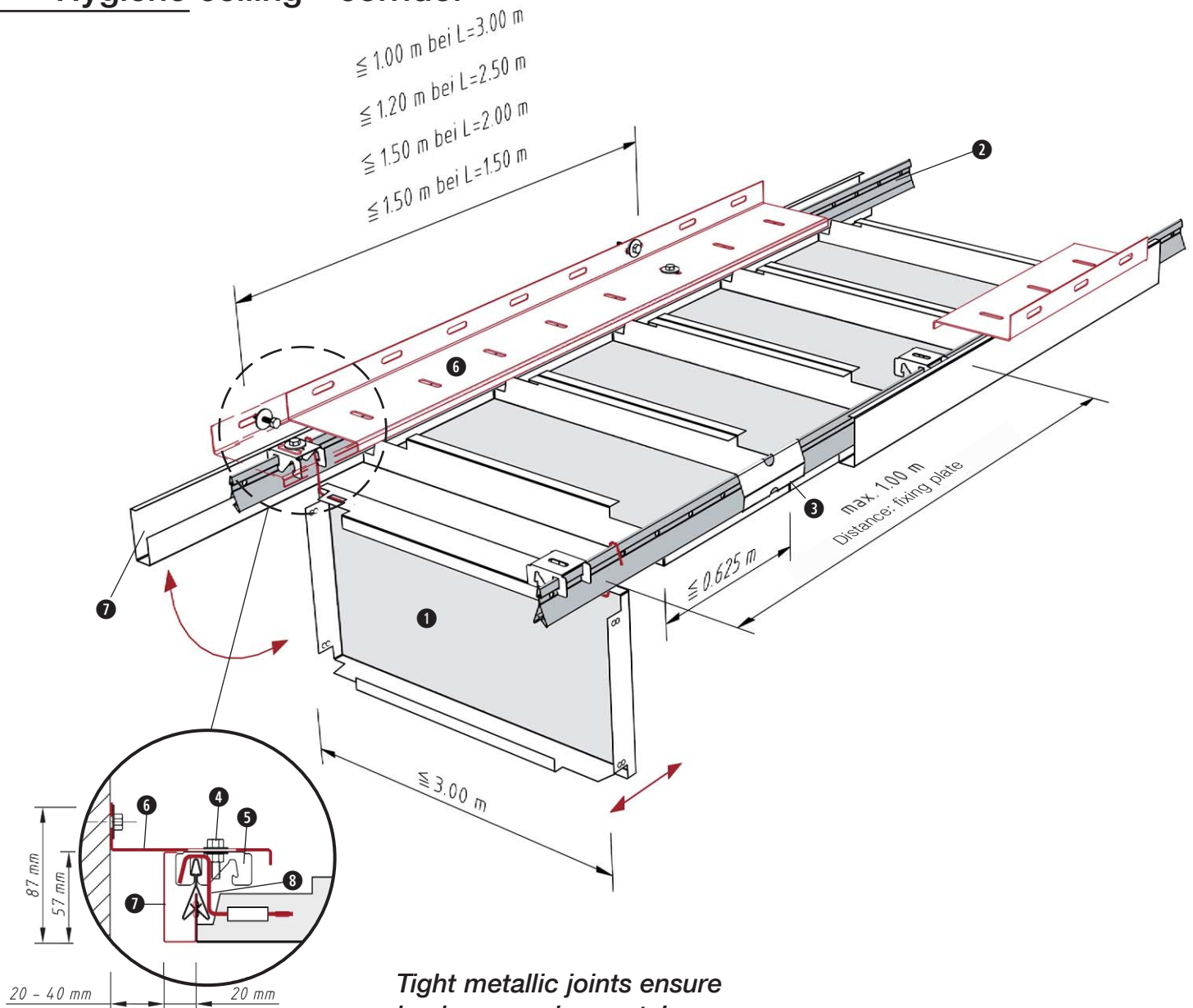

Tight metallic joints ensure hygiene requirements!

Standard components required: KLK 1.2.3.4

Item	Designation	Quantity / m ²			
		L=3,0 m	L=2,5 m	L=2,0 m	L=1,5 m
①	Long span tile				
②	Clipping rail 16/38	0.67	0.80	1.00	1.34 metres
③	Main runner connector	0.17	0.20	0.25	0.34 units
④	Screw M6, complete	0.67	0.67	0.67	0.89 units
⑤	Fixing plate	0.67	0.67	0.67	0.89 units
⑥	Wall angle for hospital	0.67	0.80	1.00	1.34 metres
⑦	Shadow section for hospital	0.67	0.80	1.00	1.34 metres
⑧	DOOR wire bracket	---	---	---	---

Installation

Distance between fixing points according to the sketch

Ceiling weight per m²: alu app. 5kg
steel app. 8kg



28.06.2014

**KQR
1.1.1.1**

FURAL® Acoustic Ceilings
Square tiles – clip-in system

Cleanroom ceiling without overpressure - with quick suspension

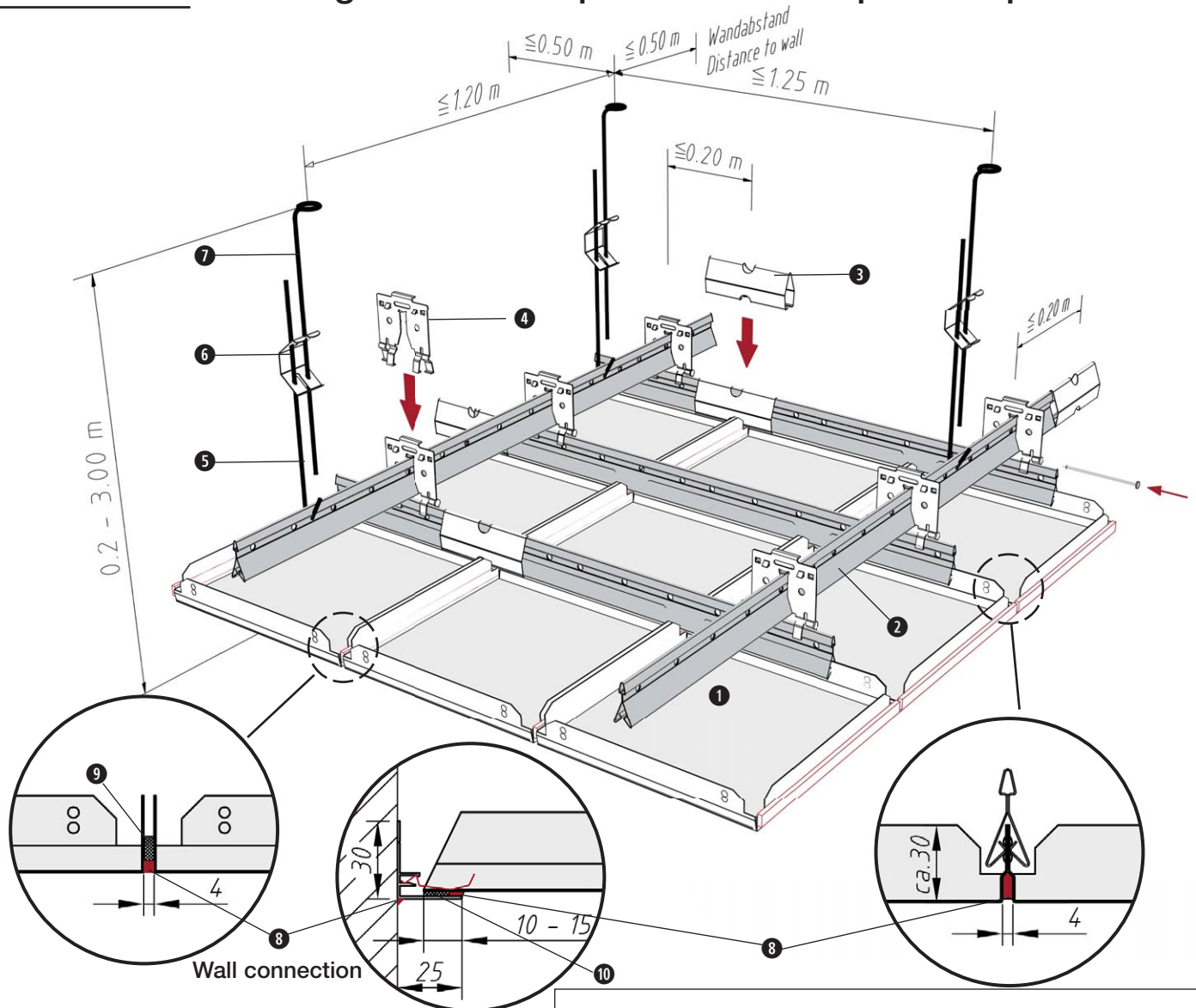

Absolutely air-tight. Tile joints are sealed.



Installation

Distance between fixing points according to the sketch
Ceiling weight per m²: alu app. 5 kg
steel app. 8 kg

**Standard components
required: KQR 1.1.1.1**

Item	Designation	Quantity / m ²		
		625	600	
①	Ceiling tile, sharp edged. plain 2 sides with 2 mm crimp, 1 side with 4 mm sealing tape	2.56	2.78	units
②	Clipping rail 16/38	2.40	2.47	metres
③	Main runner connector	0.60	0.62	units
④	Suspension key + security pin	1.28	1.33	units
⑤	Suspension wire with hook	0.67	0.67	units
⑥	Spring bracket	0.67	0.67	units
⑦	Suspension wire with loop	0.67	0.67	units
⑧	PU-sealing compound	50	52	ml
⑨	PE sealing tape 10/4	1.60	1.67	metres
⑩	PE sealing tape 10/2	-	-	

**KLR
1.2.0.2**

FURAL® Acoustic Ceilings
Long span tiles – clip-in system

Cleanroom ceiling without overpressure - with nonius suspension

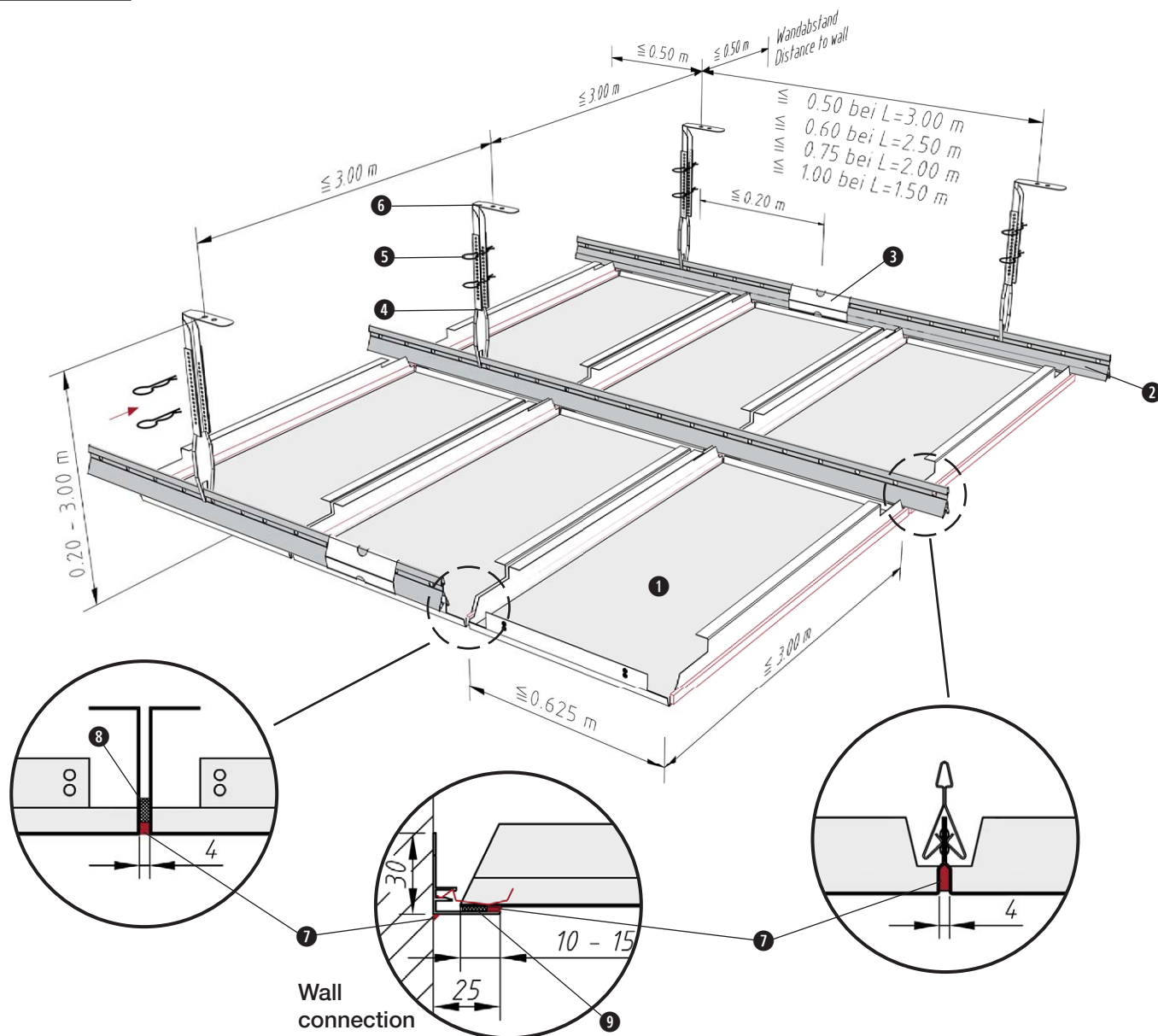

*Elegant visual impression
and air tight*

Standard components

required: KLR 1.2.0.2

Item	Designation	Quantity / m ²				
		L=3,0 m	L=2,5 m	L=2,0 m	L=1,5 m	
①	Long span tile					
②	Clipping rail 16/38	0.33	0.40	0.50	0.67	metres
③	Main runner connector	0.08	0.10	0.13	0.17	units
④	Lower nonius	0.67	0.67	0.67	0.67	units
⑤	Securing pin	1.34	1.34	1.34	1.34	units
⑥	Upper nonius	0.67	0.67	0.67	0.67	units
⑦	PU-sealing compound	---	---	---	---	
⑧	PE sealing tape 10/4	---	---	---	---	
⑨	PE sealing tape 10/2	---	---	---	---	

Installation

Distance between fixing points
according to the sketch
Ceiling weight per m²: alu app. 5 kg
steel app. 8 kg



KLK 1.2.0.2 Kühl

FURAL® Acoustic Ceilings Long span tiles – clip-in system

Cooling ceiling - suitable for copper, aluminium and plastic cooling pipes

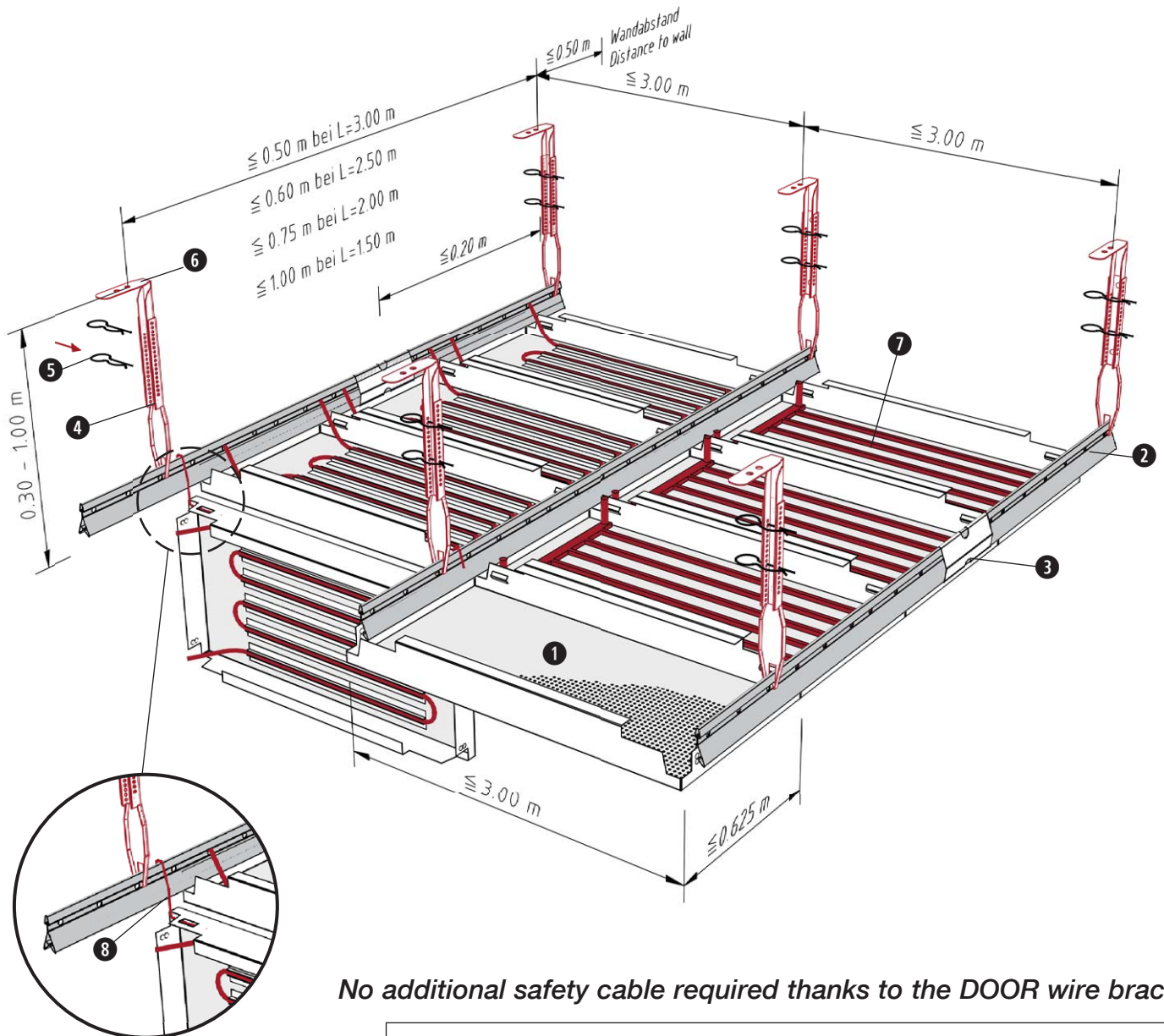

No additional safety cable required thanks to the DOOR wire bracket

Installation

recommended tile area:
max. 1 m²,
larger tile area on request

Standard components

required: KLK 1.2.0.2 Kühl Quantity / m²

Item	Designation	L=3,0 m	L=2,5 m	L=2,0 m	L=1,5 m	
①	Long span tile					
②	Clipping rail 16/38	0,33	0,40	0,50	0,67	metres
③	Main runner connector	0,08	0,10	0,13	0,17	units
④	Lower nonius	0,67	0,67	0,67	0,67	units
⑤	Securing pin	1,34	1,34	1,34	1,34	units
⑥	Upper nonius	0,67	0,67	0,67	0,67	units
⑦	Cooling system	-	-	-	-	
⑧	DOOR wire bracket	depends on tile width				

KLB
5.2.1.2 Kühl

FURAL® Acoustic Ceilings
Long span tiles – strip grid system

Cooling ceiling - Suitable for copper, aluminium and plastic cooling pipes

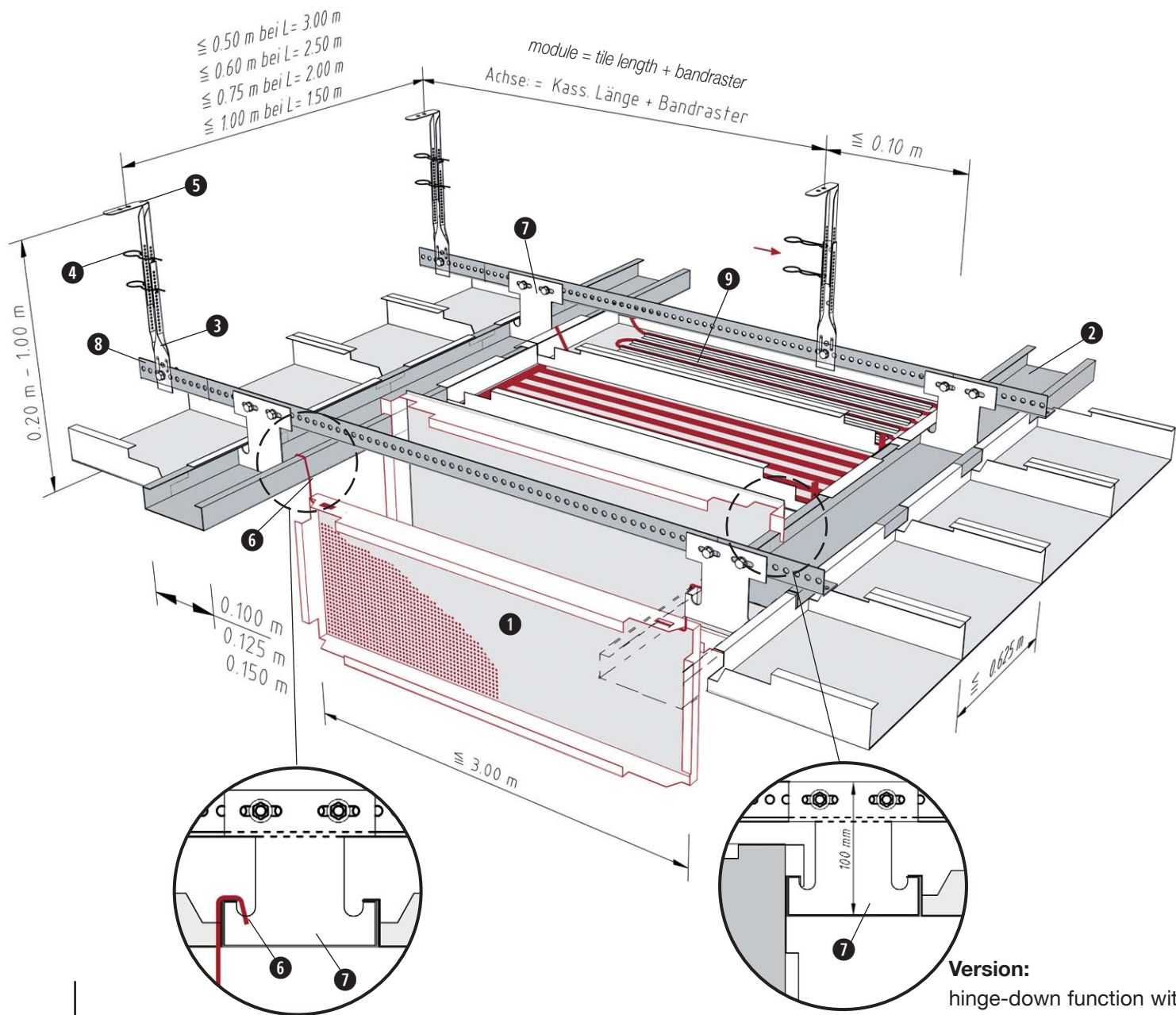

Strip grid with tiles,
that can be hinged down.

Installation

recommended tile area: max. 1 m²,
larger tile area on request

- ① Strip grid tile
- ② Main runner (strip grid)
- ③ Lower nonius
- ④ Securing pin
- ⑤ Upper nonius
- ⑥ DOOR wire bracket
- ⑦ Grid element hanger
- ⑧ Grid bracket 30/30
- ⑨ Cooling system

FURAL





F FLOATING CEILINGS



ADVANTAGES :

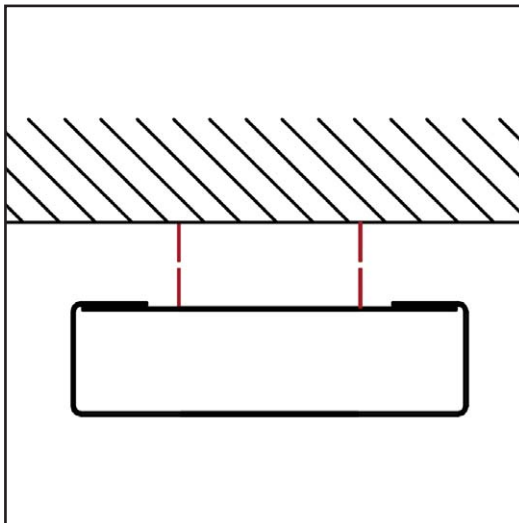

› Impressively functional

- High acoustic efficiency
- Ideal with cooling and heating function
- Several installation systems possible

› High flexibility:

- Mono or multi-part floating ceiling possible
- Different corner constructions
- Multiple installation systems combinable

› Visual benefits:

- Precise manufacturing guarantees perfect edges
- Formats/perforations/color: free choice option
- Floating elements convey lightness

Formats:	Subconstruction:	Function:	Page:
Floating ceiling	without frame	room	106
Floating ceiling	with frame	room	107-109
Floating ceiling	special shapes	room	110

Floating ceiling - without frame

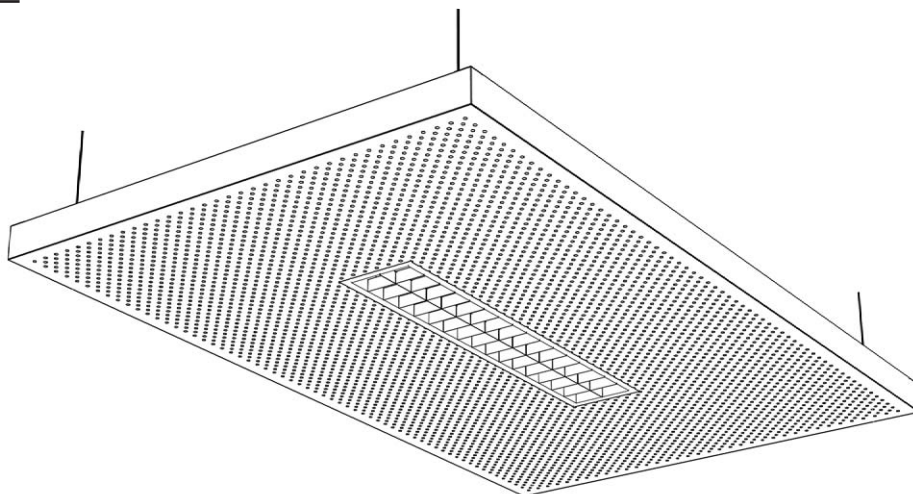

- › Standard formats: 1,200 x 2,400 mm
1,200 x 1,800 mm
1,200 x 1,200 mm
- › Max. dimensions: 1,250 x 3,000 mm
- › Suspension: Great variety of standard suspension versions are possible
e.g.: wire suspension, threaded rod, nonius suspension etc.

Edges:

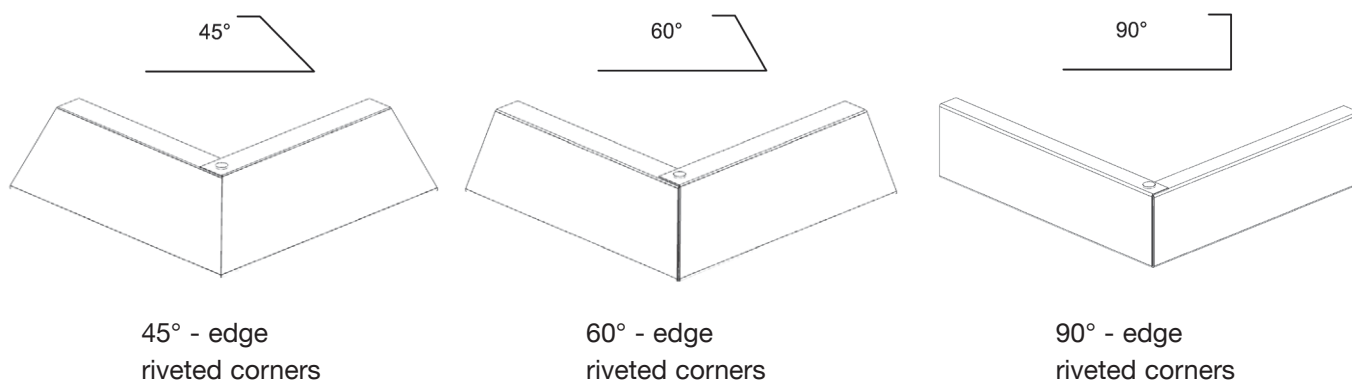

Multi-part floating ceiling

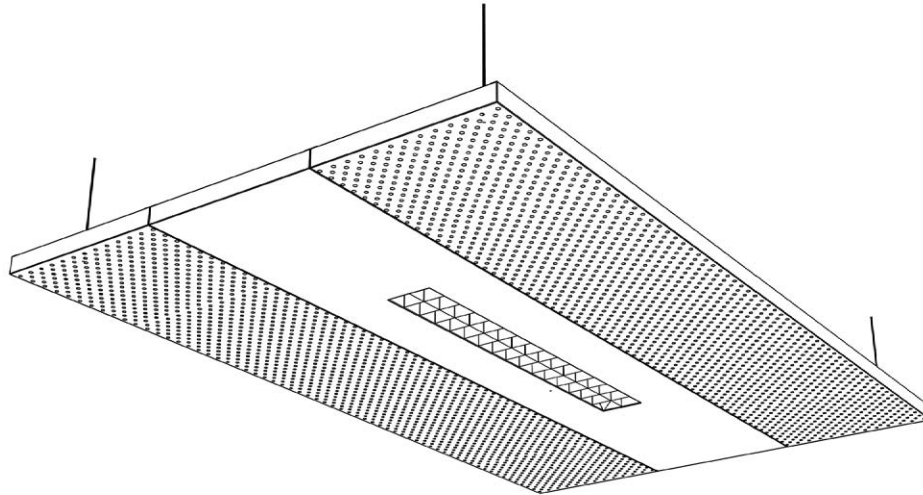

without frame

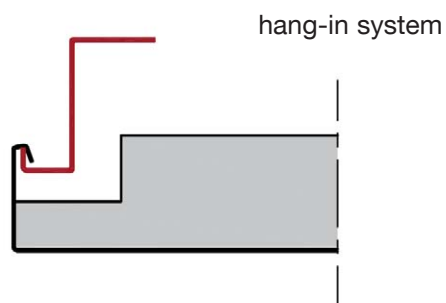

with frame

clip-in system with trimming profile

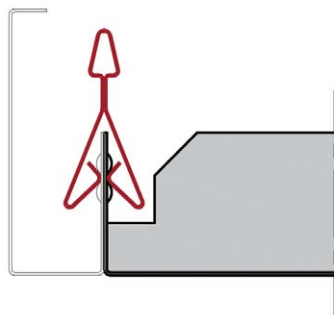

G-trimming profile with SWING-tile

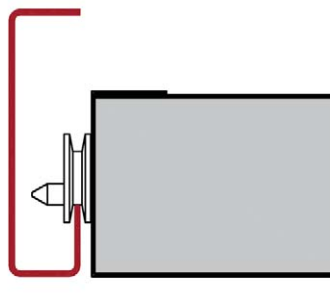

G-trimming profile with Z-support

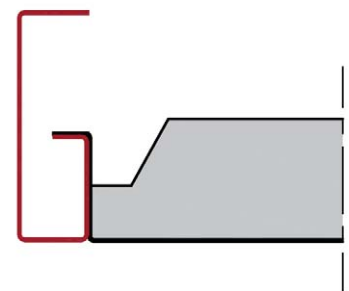



Multi-part floating ceiling - with G-profile frame

- › Max. length of floating ceiling: unlimited
- › Max. width of floating ceiling: 2,200 mm
- › Max. distance between fixing points: 1,500 mm
- › Max. tile width: 1,250 mm
- › Max. tile length: 2,140 mm

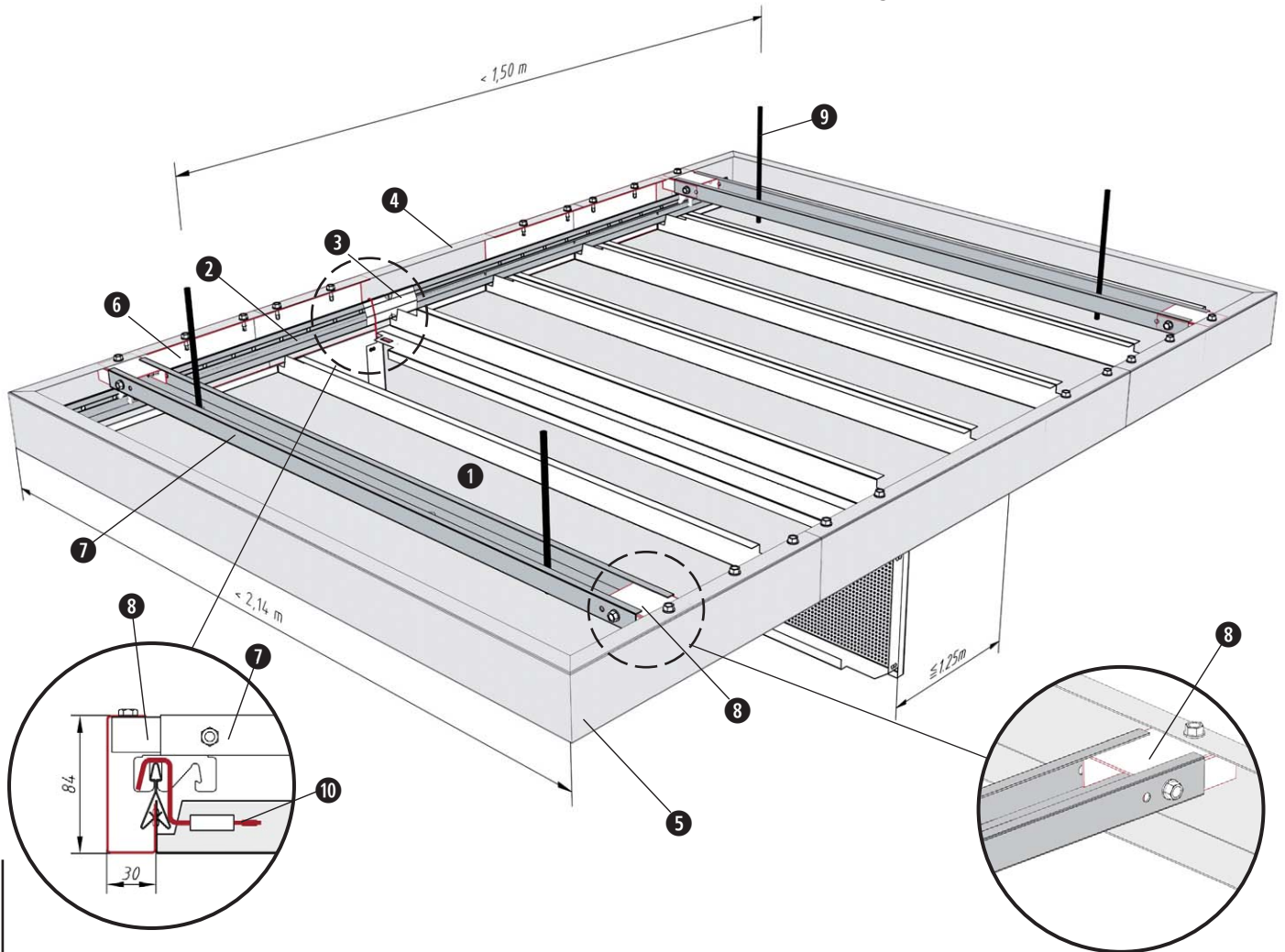

- ① Clip-in tile
- ② Clipping rail 16/38
- ③ Main runner connector
- ④ G-profile longitudinally 84 x 30 mm
- ⑤ G-profile on the front side incl. corner construction, one piece
- ⑥ Main runner connector for G-profile
- ⑦ C-support profile incl. holes for the locking slides and the suspension
- ⑧ locking slides
- ⑨ suspension, e.g. threaded rod, wire rope
- ⑩ DOOR-wire bracket

Installation

Distance between fixing points according to the sketch
 Ceiling weight per m²: steel app. 10kg
 further instructions: p. 76-77

Special shapes

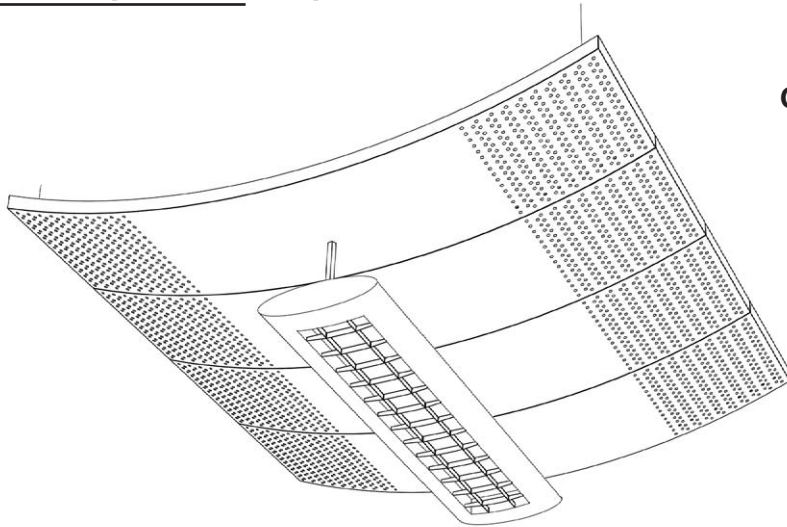

curved / convex

curved / concave

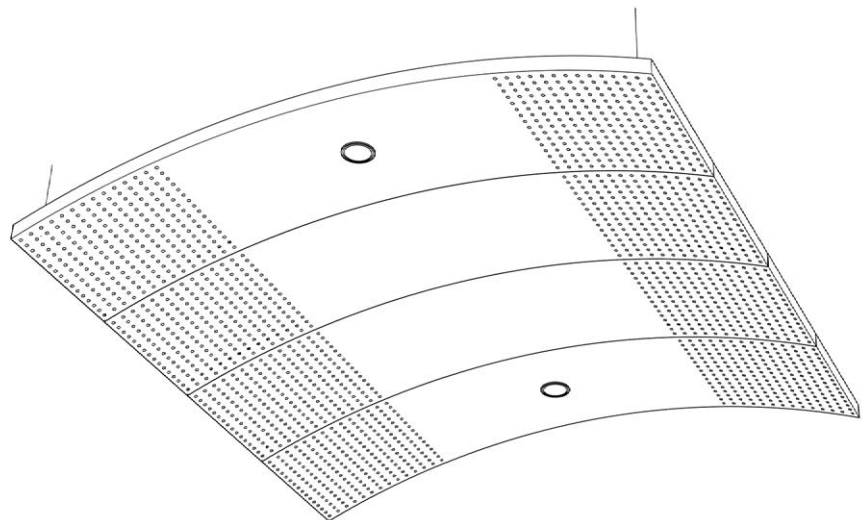

further design versions:

- › curved
- › trapezoid
- › triangular
- › central strip grid
- › integrated roundings
- › Multiple installation systems can be combined eg. multi-part floating ceilings with G-profile frame and central strip grid. (see Page 111)
- › Fittings such as lights, air outlets, etc. can be optimally integrated



Perforations

FURAL® Acoustic Ceilings Perforations – sound absorption

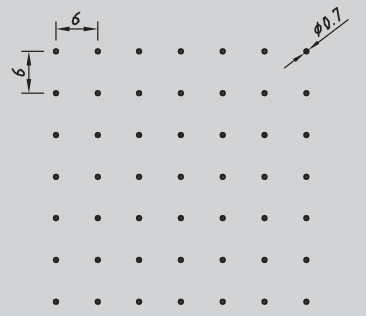
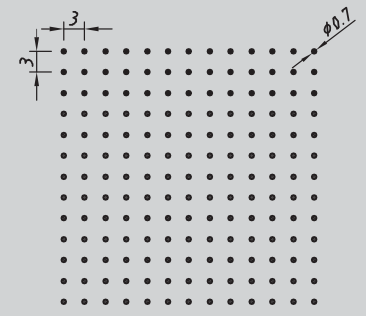
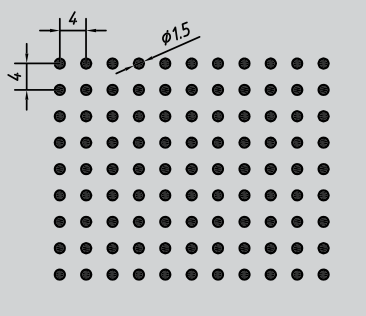
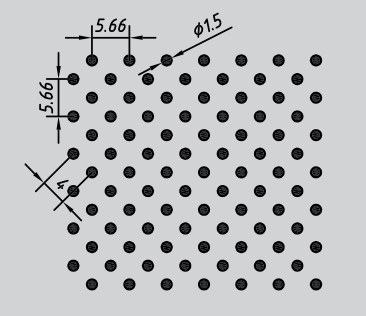
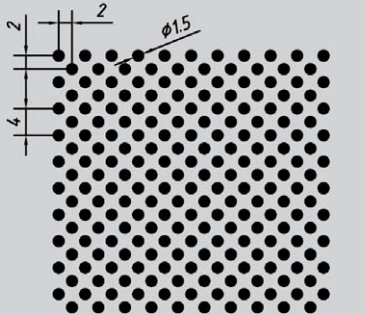
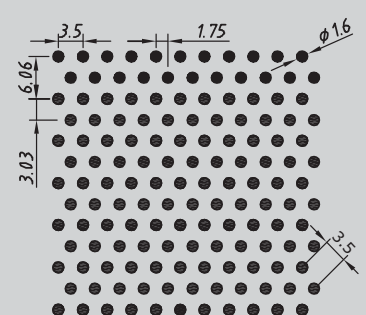
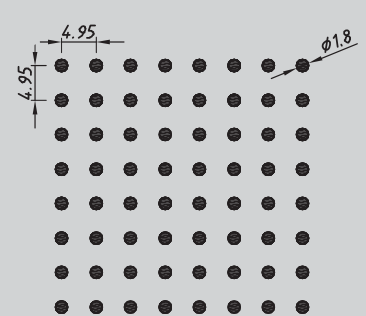
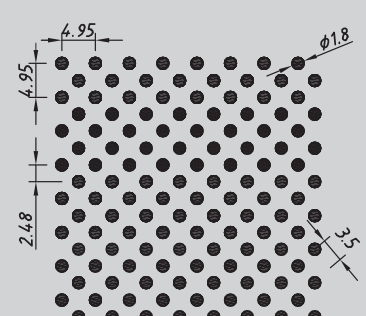
<p>FURAL 0701 with fleece Ø 0.7 mm Free cross-section 1% Suspension height 200 mm Class D $\alpha_W = 0.50$ (LM) max. perforation exterior size 1.140 mm</p>	 <p>Rg 0.7 - 6.0 (acc. to DIN 24041)</p>	<p>FURAL 0704 with fleece Ø 0.7 mm Free cross-section 4% Suspension height 200 mm Class C $\alpha_W = 0.75$ max. perforation exterior size 1.140 mm</p>	 <p>Rg 0.7 - 3.0 (acc. to DIN 24041)</p>
<p>FURAL 1511g with fleece Ø 1.5 mm Free cross-section 11% Suspension height 200 mm Class C $\alpha_W = 0.75$ max. perforation exterior size 1.486 mm</p>	 <p>Rg 1.5 - 4.0 (acc. to DIN 24041)</p>	<p>FURAL 1511d with fleece Ø 1.5 mm Free cross-section 11% Suspension height 200 mm Class C $\alpha_W = 0.75$ max. perforation exterior size 1.486 mm</p>	 <p>Rd 1.5 - 4.0 (acc. to DIN 24041)</p>
<p>FURAL 1522d with fleece Ø 1.5 mm Free cross-section 22% Suspension height 200 mm Class C $\alpha_W = 0.70$ max. perforation exterior size 1.486 mm</p>	 <p>Rd 1.5 - 2.83 (acc. to DIN 24041)</p>	<p>FURAL 1620 with fleece Ø 1.6 mm Free cross-section 20% Suspension height 200 mm Class B $\alpha_W = 0.80$ max. perforation exterior size 1.440 mm</p>	 <p>Rv 1.6 - 3.5 (acc. to DIN 24041)</p>
<p>FURAL 1810 with fleece Ø 1.8 mm Free cross-section 10% Suspension height 200 mm Class C $\alpha_W = 0.75$ max. perforation exterior size 1.413 mm</p>	 <p>Rd 1.8 - 4.95 (acc. to DIN 24041)</p>	<p>FURAL 1821 with fleece Ø 1.8 mm Free cross-section 21% Suspension height 200 mm Class C $\alpha_W = 0.75$ max. perforation exterior size 1.413 mm</p>	 <p>Rd 1.8 - 3.5 (acc. to DIN 24041)</p>

FURAL

➔ Direction of perforation

Perforations

FURAL® Acoustic Ceilings Perforations – sound absorption

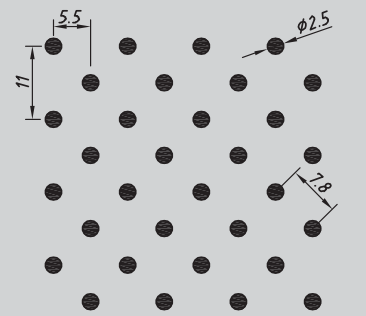
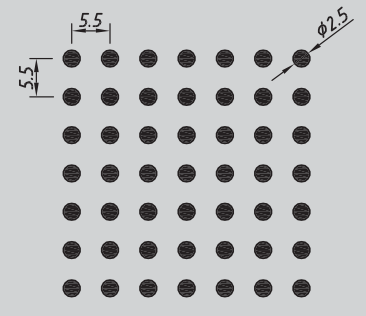
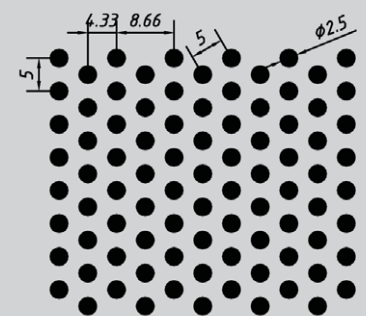
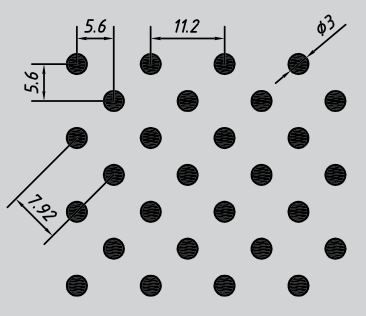
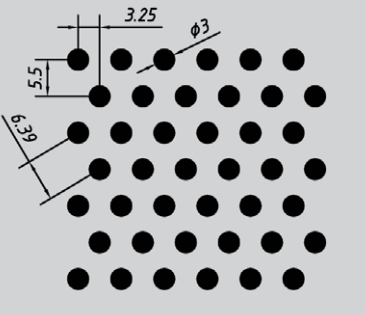
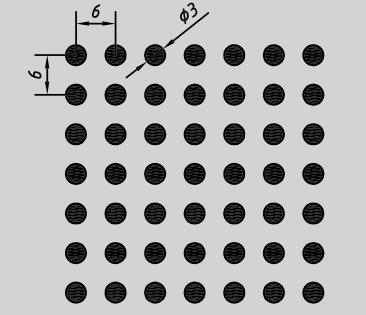
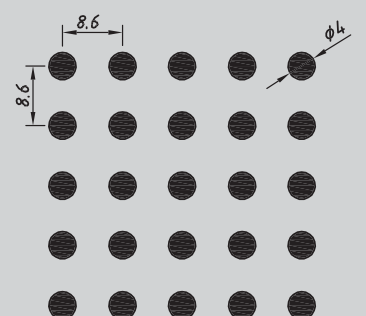
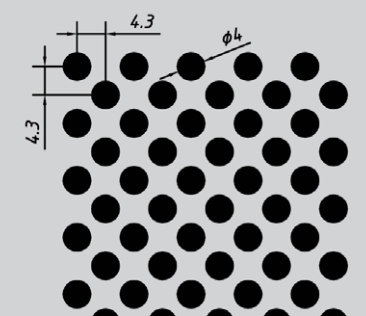
<p>FURAL 2508 with fleece Ø 2.5 mm Free cross-section 8% Suspension height 200 mm Class C $\alpha_W = 0.75$ max. perforation exterior size 1.458 mm</p>	 <p>Rd 2.5 - 7.8 (acc. to DIN 24041)</p>	<p>FURAL 2516 with fleece Ø 2.5 mm Free cross-section 16% Suspension height 200 mm Class B $\alpha_W = 0.80$ max. perforation exterior size 1.458 mm</p>	 <p>Rg 2.5 - 5.5 (acc. to DIN 24041)</p>
<p>FURAL 2523 with fleece Ø 2.5 mm Free cross-section 23% Suspension height 200 mm Class C $\alpha_W = 0.75$ (L) max. perforation exterior size 1.458 mm</p>	 <p>Rv 2.5 - 5.0 (acc. to DIN 24041)</p>	<p>FURAL 311 with fleece Ø 3.0 mm Free cross-section 11% Suspension height 200 mm Class C $\alpha_W = 0.75$ max. perforation exterior size 600 mm</p>	 <p>Rd 3 - 7.92 (acc. to DIN 24041)</p>
<p>FURAL 320d with fleece Ø 3.0 mm Free cross-section 20% Suspension height 200 mm Class C $\alpha_W = 0.75$ (L) max. perforation exterior size 1.403 mm</p>	 <p>Rv 3.0 - 6.39 (acc. to DIN 24041)</p>	<p>FURAL 320g with fleece Ø 3.0 mm Free cross-section 20% Suspension height 200 mm Class C $\alpha_W = 0.75$ (L) max. perforation exterior size 1.430 mm</p>	 <p>Rg 3.0 - 6.0 (acc. to DIN 24041)</p>
<p>FURAL 417 with fleece Ø 4.0 mm Free cross-section 17% Suspension height 200 mm Class B $\alpha_W = 0.80$ max. perforation exterior size 606 mm</p>	 <p>Rg 4.0 - 8.6 (acc. to DIN 24041)</p>	<p>FURAL 433 with fleece Ø 4.0 mm Free cross-section 33% Suspension height 200 mm Class B $\alpha_W = 0.80$ max. perforation exterior size 606 mm</p>	 <p>Rd 4.0 - 6.1 (acc. to DIN 24041)</p>



➔ Direction of perforation

Perforations

FURAL® Acoustic Ceilings Perforations – sound absorption

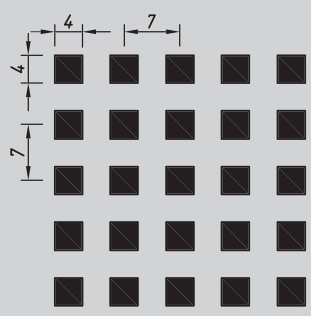
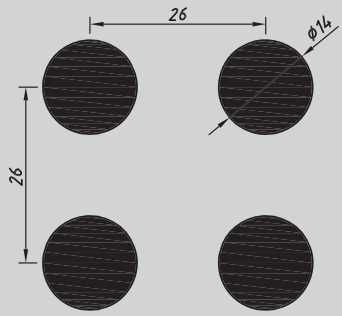
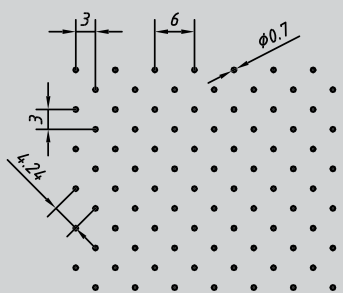
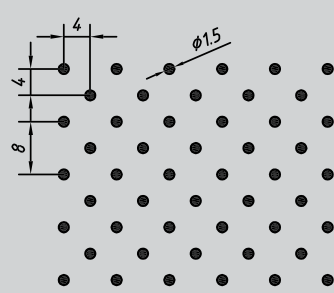
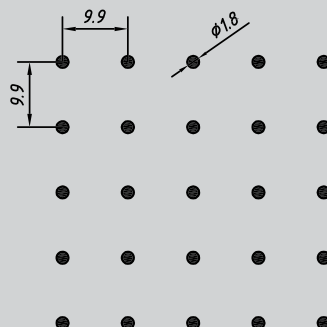
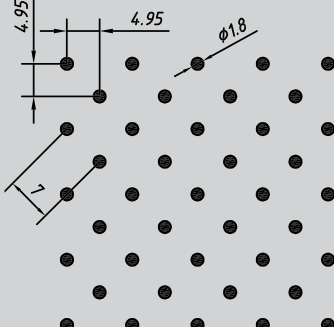
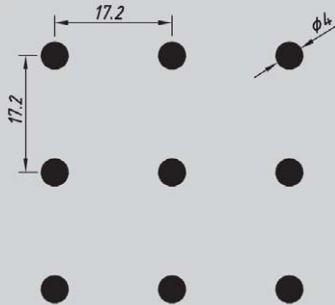
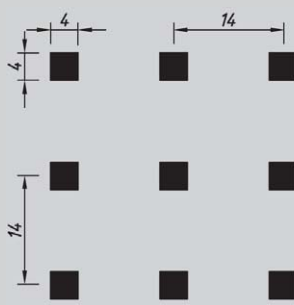
<p>FURAL 4433 with fleece □ 4.0 mm Free cross-section 33% Suspension height 200 mm Class B $\alpha_w = 0.80$ max. perforation exterior size 630 mm</p>	 <p>Qg 4.0 - 7.0 (acc. to DIN 24041)</p>	<p>FURAL 1423 with fleece Ø 14.0 mm Free cross-section 23% Suspension height 200 mm Class C $\alpha_w = 0.75$ max. perforation exterior size 598 mm</p>	 <p>Rg 1.4 - 26.0 (acc. to DIN 24041)</p>
<p>FURAL 0702 with fleece Ø 0.7 mm Free cross-section 2% max. perforation exterior size 1.140 mm</p>	 <p>Rd 0.7 - 4.24 (acc. to DIN 24041)</p>	<p>FURAL 1506 with fleece Ø 1.5 mm Free cross-section 6% max. perforation exterior size 1.486 mm</p>	 <p>Rd 1.5 - 5.66 (acc. to DIN 24041)</p>
<p>FURAL 1802 with fleece Ø 1.8 mm Free cross-section 2% max. perforation exterior size 1.413 mm</p>	 <p>Rg 1.8 - 9.9 (acc. to DIN 24041)</p>	<p>FURAL 1805 with fleece Ø 1.8 mm Free cross-section 5% max. perforation exterior size 1.413 mm</p>	 <p>Rd 1.8 - 7.0 (acc. to DIN 24041)</p>
<p>FURAL 404 with fleece Ø 4.0 mm Free cross-section 4% max. perforation exterior size 606 mm</p>	 <p>Rg 4.0 - 17.2 (acc. to DIN 24041)</p>	<p>FURAL 4408 with fleece □ 4.0 mm Free cross-section 8% max. perforation exterior size 630 mm</p>	 <p>Qg 4.0 - 14.0 (acc. to DIN 24041)</p>



Direction of perforation

Stretch metal

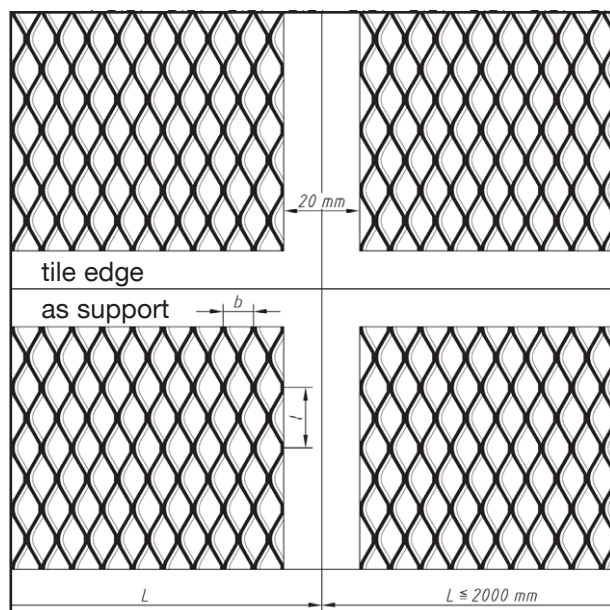

> Design:

- Tiles with factory-fitted expanded metal grid stretch metal – mesh size freely selectable.
- Standard mesh: [16 / 8 / 1,5 / 1] mm
- Visible revolving tile edge app. 10 mm
- Coating possible in all RAL colors.

> Systems:

- As clip-in system
Option: Installation of FURAL-DOOR-Systems to open the ceiling for revision work
- As lay-in system for T24-rail

> Function:

- Acoustically effective ceiling with acoustic fleece (for test values see folder 'Test values sound absorption')
- Designed for mounting with **FURAL** clip-in system for fast and economical installation

Galaxy

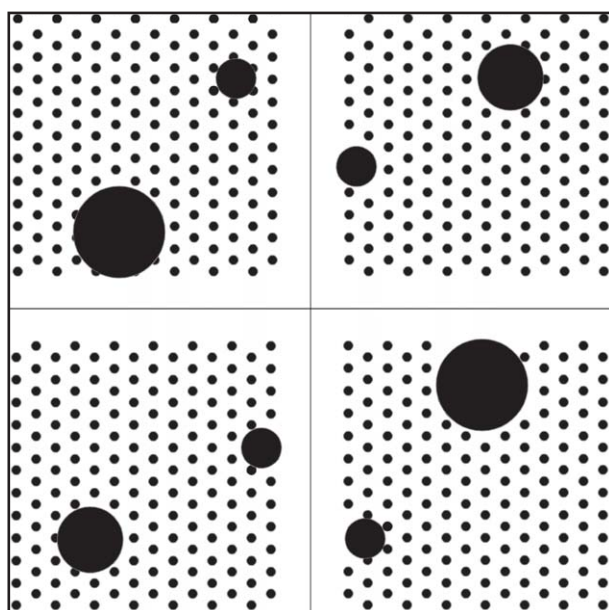

Perforation: 1620
GALAXY effect
(hole $\varnothing = [6,3 / 10,3 / 14,3]$)
 $\alpha_w = 0,8 /$ Class: B

> Easy to assemble:

- Quick installation on standard substructure

> Optics:

- Unique ceiling appearance with galaxy effect

> Acoustic:

- Acoustically effective through basic perforation

13

13 REASONS TO
SAVE INSTALLATION
TIME BY USING FURAL
CLIPPING RAILS

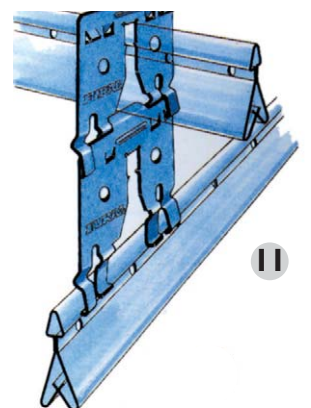
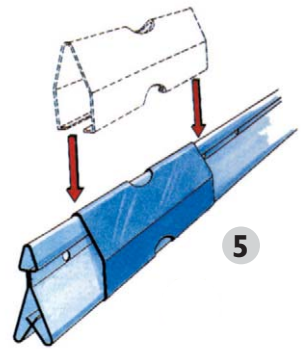
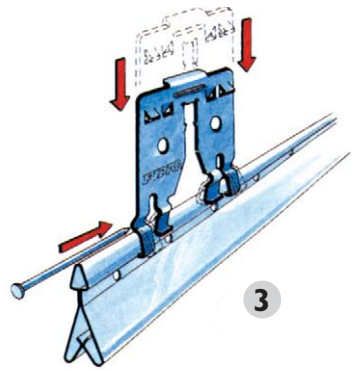
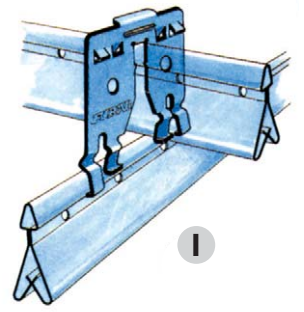

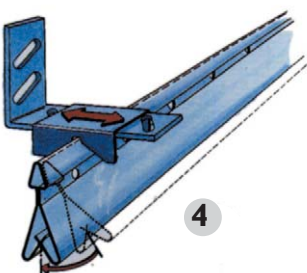
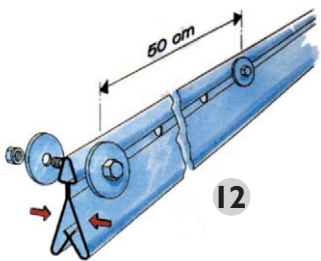
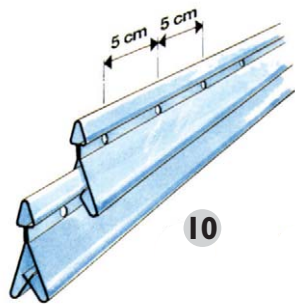
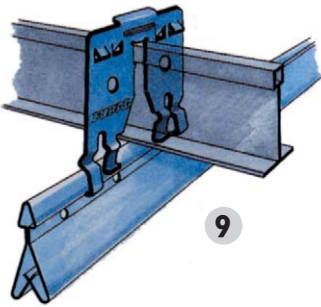
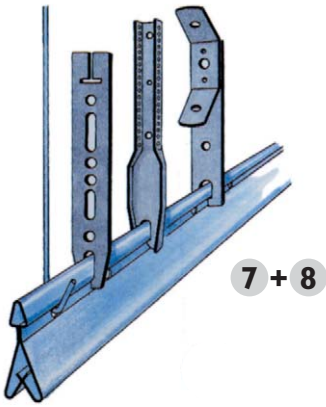

1 ONE PROFILE

Clipping rail + grid rail

2 CLIPPING RAIL

Remnants can be used for longitudinal connection

3 CONNECTION

clipping rail to grid rail by use of suspension key
= **FURAL** clip-in method

4 COMFORTABLE

alignment of rails, sliding in either direction is possible

5 ONE MAIN RUNNER CONNECTOR

with free edges - perfect connection of clipping rail and grid rail

6 CLIPPING RAIL

T-connector - any angle can be chosen
(included in the delivery program of **FURAL**)

7 SUSPENSION

the use of quick suspension elements is possible with a distance of 5 cm between suspension points

8 ALSO SUITABLE

for any conventional type of nonius suspension - sliding suspension

9 USING

T-rails - e.g. as grid rails is a possible option with the system

10 DOUBLE CLIPPING TRAIL

with clip-in connection for wide span girders (no special section)
on stock at any time

11 FOR LOW SUSPENSION

-with nonius short suspension

12 FOR ENHANCED SAFETY

additional use of screw lock is possible

13 ACCURATE

height alignment in case of single and double web installation

D DISMANTLING

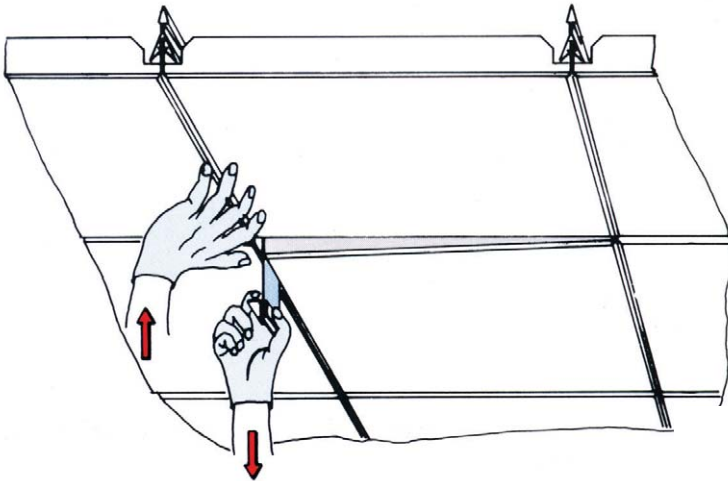
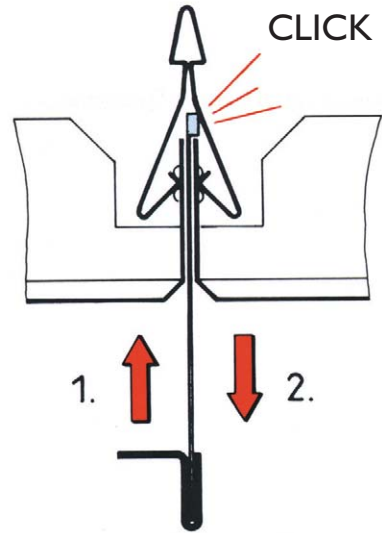

> Dismantling:

- Insert ceiling opener carefully into the ceiling joint until the tongue engages
- Pull the tile out of the clipping rail by lever action of the ceiling opener.

> Demo video:

- Scan the QR - code to watch the dismantling process on youtube

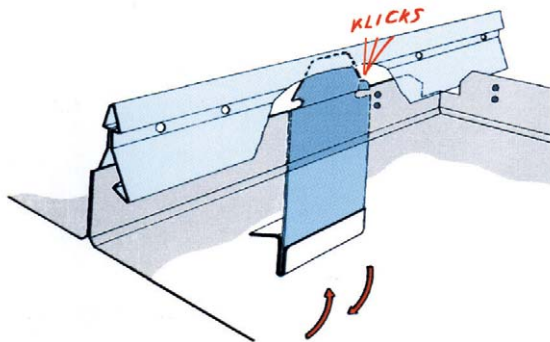

> Adjust:

- Pull tiles out of the wall mounting section and adjust.

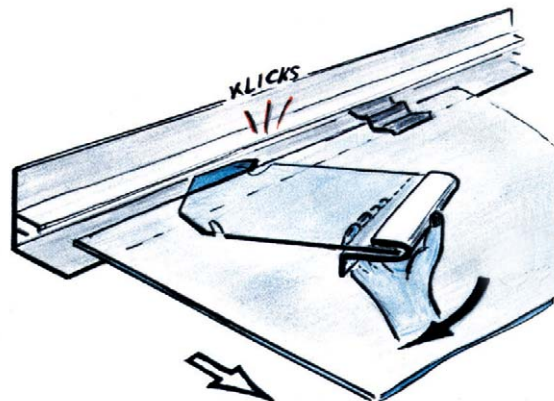





Salatbuffet

Käsebraten mit
Gemüsch
Anlauchensuppe

Gebäckerei Tolu
Wegemilch
Eis

Spaghetti "Milanese"
Seser





Project:

PALLAZZO LOMBARDIA
BSZ ST. PÖLTEN
RAIFFEISENBANK WELS SÜD
PETROM CITY, BUKAREST
KORAMIC, KORTRIJK
BERNEGGER, MOLLN
GERENCIA INFORMATICA MADRID
BBRZ LINZ
KLINIKUM NÜRNBERG NORD
SKA ST. RADEGUND
CHECK-IN-3, WIEN
BSZ ST. PÖLTEN
EIB LUXEMBURG
SKA ST. RADEGUND
HANDWERKSKAMMER DÜSSELDORF
BBRZ LINZ
OECONOMICUM DÜSSELDORF
BÜGELBAUTEN BERLIN
KORAMIC, KORTRIJK
PVA WIEN
BREHMSTRASSE WIEN
ZUKUNFTSWERKSTATT FURAL

System:

Page:

2
KLK 4
KLK 17
KLH 24
KLH/SEGEL 32
KQT 36
KQB/SWING 44
KLE 54
SWING/F30 62
KQK 68
KLH 78
KLK/DOOR 83
SEGEL 94
KLK 97
KLK 100
KLB 103
SEGEL 104
SEGEL 108
KLH/SEGEL 111
KLK 120
KLH 121
122

contact

➤ FURAL Systeme in Metall GmbH
Cumberlandstraße 62, A-4810 Gmunden
www.fural.com, fural@fural.at, fax: -11
+43/(0)76 12/74 851-0



Scan the QR code to find the contact person on the FURAL website.



FURAL[®]

Tel. +43 - (0) 7612 - 74 851 - 0
GMUNDEN

Cumberlandstraße 62 • A-4810 Gmunden
Tel. +43 - (0) 7612 - 74 851 - 0 • Fax +43 - (0) 7612 - 74 851 - 11
www.fural.com • fural@fural.at