

Sorption

CASA R15 Genius

Technical catalogue



QUICK FACTS

- CASA Genius control system
- Moisture-recovering enthalpy heat exchanger
- Automatic indoor air humidity control
- Continuous ventilation without the need for frost protection
- Automatic summer function and passive cooling
- External coils for heating and cooling as an option
- Can be connected to the automated building management system (I/O/Modbus)
- Mounted on a firm foundation

UNIT TECHNICAL CONTENT

Air flow range	100-475 l/s 360-1710 m ³ /h
Dimensions, w x l x h	1080 x 788 x 1201 mm
Duct outlets	4 x Ø 250 mm
Energy calculations and acoustic data	procasa.swegon.com
Connection power	1020 W
Power connection	230 V, 50 Hz, 10 A
Fans	1000 W, EC
Filters	ISO ePM1 50% (F7) filters for supply air and extract air
Colour	Exterior White, RAL 9016 (corresponds to NCS S0502-G50Y)

Content

Technical description	3
CASA Genius control	6
Design data	8
Air flows	10
Acoustic data	10
Dimensions and weight	11
Functional diagram	12
External connections	14
Internal connections.....	15
Installation options	16
Product codes	18

Technical description

Swegon CASA R15 Genius

Ventilation unit equipped with a rotating enthalpy heat exchanger (1080 x 788 x 1201 mm, Ø 250 mm), suitable for large houses (475 l/s, 850 m²), office or conference rooms.

The moisture-recovering enthalpy heat exchanger ensures continuous ventilation without the need for frost protection. High moisture recovery (over 80%) enables indoor air humidity control.

Indoor environmental quality

Ventilation control

The unit is controlled steplessly with automation functions to guarantee the best indoor environmental quality. The user can select five operating modes home, away, boost, travelling and home+ by using control panel, cooker hood or Swegon CASA app. Operation modes can be automated with unit's weekly programs.

Temperature control

The supply air temperature is controlled by the heat exchanger and, if necessary, by an optionally available external heating element or an optionally available external cooling element.

The unit has automatic summer time detection. The function sets lower supply air temperature setpoint and boost ventilation in order to bring more fresh outdoor air to the apartment during summer nights.

Moisture control

High moisture recovery must be considered when designing ventilation. The Boost mode air flow must be at least 30 % greater than the air flow in Home mode.

Moisture control is managed by the automation system, adjusting the rotation speed of the heat exchanger. Note that moisture removal temporarily reduces heat recovery.



Available variants

Standard units are available in following variants:

- Unit with enthalpy heat exchanger



Components

Fans

CASA R15 is equipped with energy efficient EC fans.

Filter

The ventilation unit is equipped with ISO ePM1 50% (F7) filters for supply air and extract air. The need of filter replacement is indicated on the control panel and on the CASA cooker hood.

Heat exchanger

The ventilation unit is equipped with a **speed-controlled rotating enthalpy heat exchanger**. Heat exchanger is controlled either to maintain the indoor air humidity and supply air temperature constant.

External connections

All connections can be made without opening the electrical box. Plug-in modules are available for external connections. Wide variety of IO functions are available.

The ventilation unit is equipped with In-build Modbus. Modbus cabling can be made easily with external cable (SEC) or module (SEM). Unit can be fully controlled with Modbus and all external IO's can be configured to Modbus usage.

Protective functions

The heat exchanger freeze protection

Under normal conditions, the enthalpy heat exchanger does not require defrost cycles when the indoor air humidity is kept at a sufficiently low level. The automation of the unit seeks to regulate the indoor air humidity by adjusting the speed of the heat exchanger and the ventilation system's airflow. If the indoor air humidity rises to a critically high level, an alarm is triggered, and the dehumidification function is activated.

The fan overheating protection

The fan overheat protection stops the fan if the temperature rises too high and is reseted automatically. If protection stops the fans an alarm is generated.

Rotor guard

Rotor guard detects that the rotor is working. Malfunction generates an alarm.

Cold supply air

The ventilation unit has built-in condensation protection. If the supply air is too cold, the ventilation unit stops and an alarm is generated

High temperature

If supply air or units internal temperature is detected dangerously high the unit is stopped and an alarm is generated.

Temperature sensors

If a sensor fault is detected, an alarm is generated. If the faulted sensor is critical the ventilation unit is stopped. The ventilation unit returns to normal mode once the fault has been corrected.

The delivery includes

- Ventilation unit
- Quick Guide
- Installation and commissioning instruction
- Product fiche

Standard connections

- Power cord with earthed plug (2 m)
- Modular cable with RJ9 connector (1.5 m)
- Freely configurable I/O contacts for connection of accessories (2 pcs.)

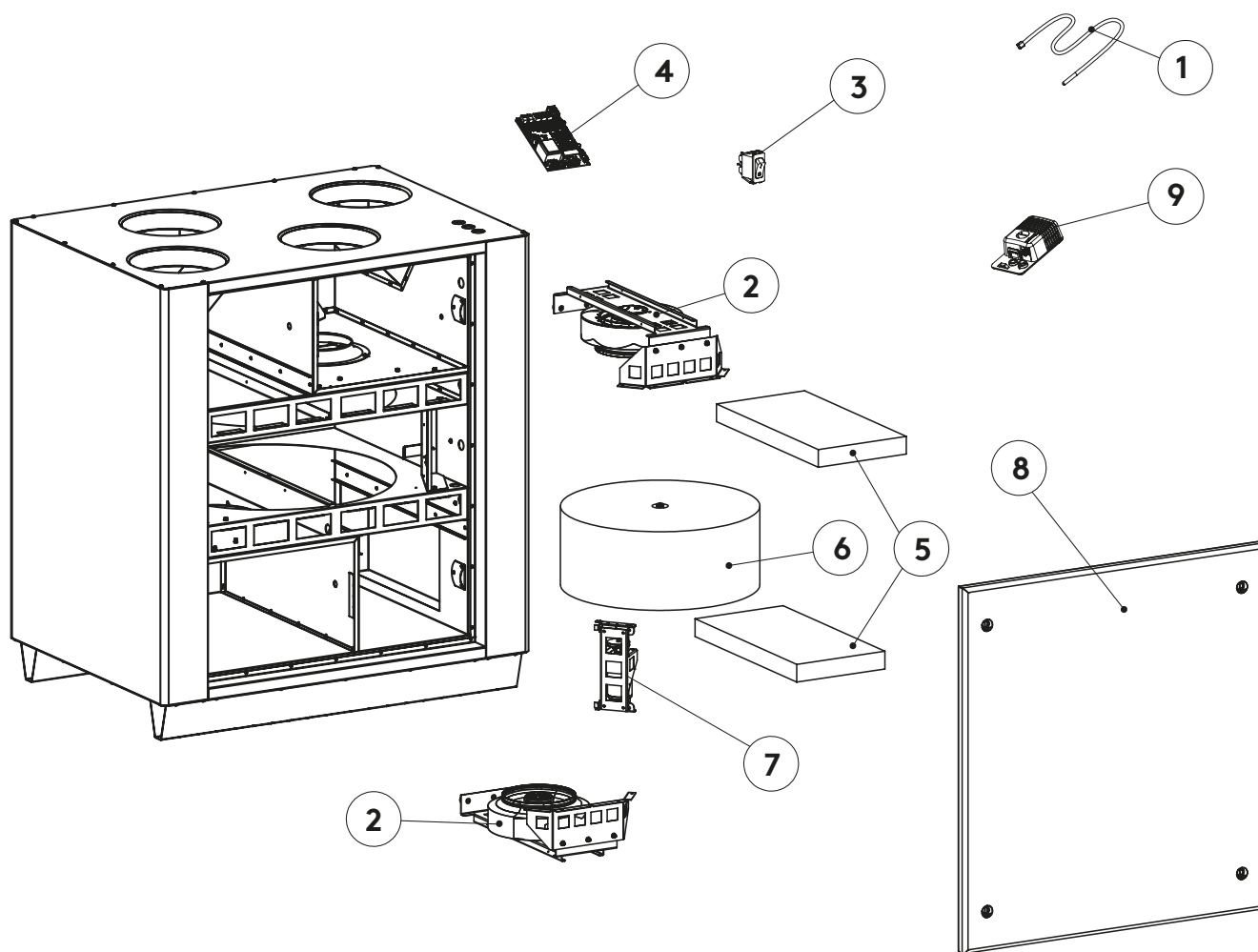

1. Temperature sensor
2. Fan
3. Operating switch
4. Genius control board
5. ISO ePM1 50% (F7) filters
6. Rotor
7. Rotor motor
8. Door
9. Sensor package, RH (2 pcs.)



Swegon CASA Genius

Intelligent control of the ventilation

With Swegon CASA Genius residents can monitor the indoor air quality (RH, CO₂, VOC, °C), adjust ventilation to their wishes or let the intelligent control to adjust ventilation automatically while saving energy and providing fresh and healthy indoor air.



The Swegon CASA control panel (GC10)

Wall-mounted touch screen for external or flush mounting. From the touch screen user can monitor ventilation, change ventilation mode, change the settings and commission the ventilation unit. The screen can be connected to the home WLAN, enabling the ventilation to be controlled remotely from a Swegon CASA mobile app



The Swegon CASA app

With Swegon CASA app residents can use all the control functions remotely from their own smartphone. Users get more information about their home's air quality as well as valuable instructions and advice about the ventilation (requires Swegon Genius control panel).



The CASA Service app

for quick and easy commissioning. The app works locally together with the ventilation unit and doesn't require connection to network. The app defines the I/O connections, presets the fan speeds that correspond to specified air volumes, as well as automatically sets air volumes for home and boost mode. Finished settings can be saved in the app and copied to the next apartment (requires Swegon Genius control panel).



Swegon CASA cooker hood

With cooker hoods, it is possible to control the ventilation unit's operating mode (home, away, boost), the cooker hood's shut-off damper and the lighting in the hood. The system balances the ventilation automatically when using the cooker hood.



The Swegon CASA HOME/AWAY/BOOST control switch (GC04)

Wall-mounted control switch for selecting boost, home and away modes.



Home automation

Can be connected to the home automation for centralised monitoring and control, either directly via configurable I/O or with the aid of a separate Modbus connection module (SEM).

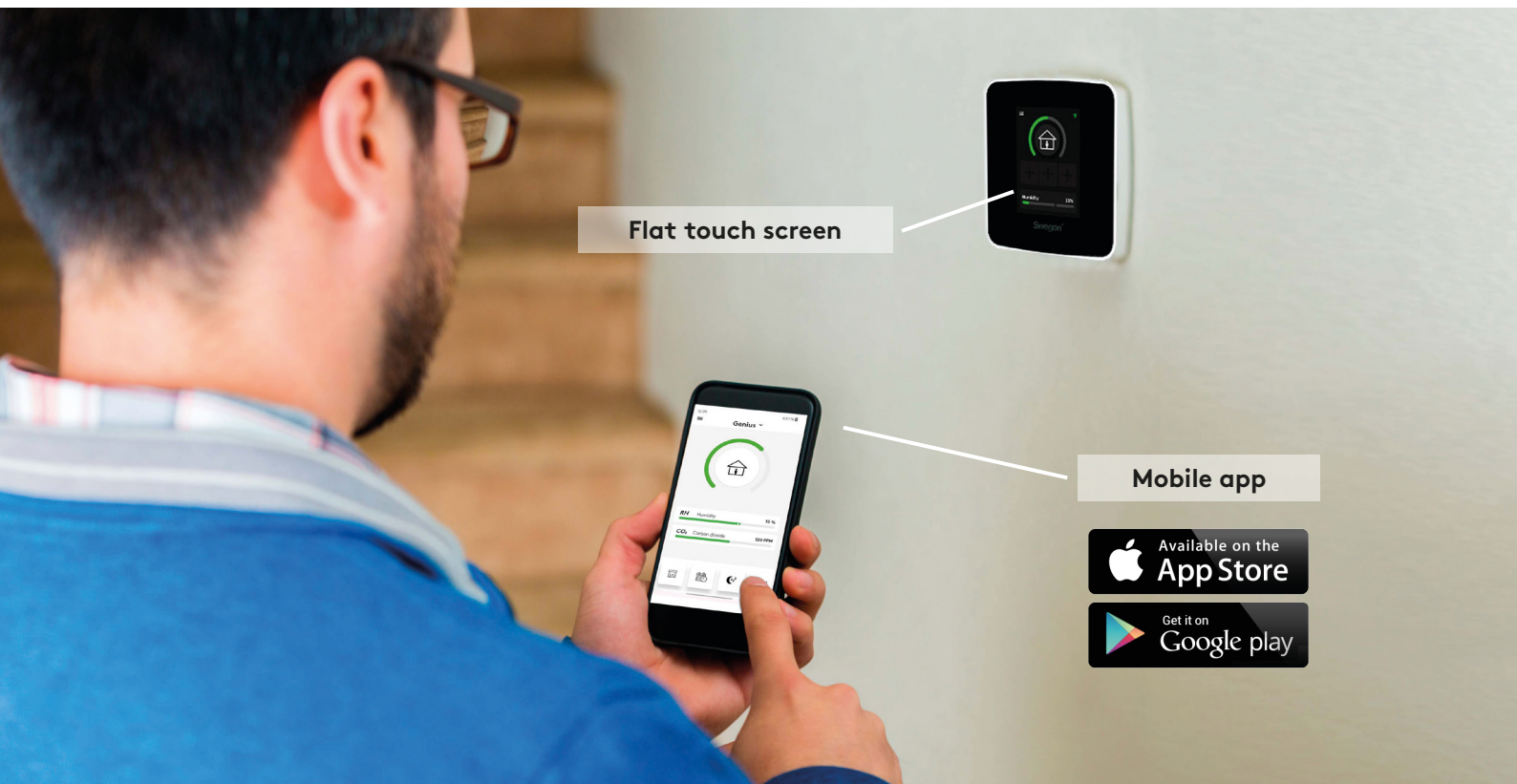

Flat touch screen

Mobile app





Basic modes

You can switch as required to an appropriate operating mode or let the pre-programmed weekly clock switch operating mode according to the diurnal rhythm you want.



Home

Normal air flow. Sufficient amount of fresh indoor air to ensure the wellbeing of the residents and the structural building elements when there are people in the home.



Home+

Higher air flow. Can be used when more ventilation is required. The home owner can change the efficiency of the operating mode from the settings.



Boost

High air flow. Used if the ventilation requirement increases, for example, when cooking, taking a bath or drying laundry, or when an unusually large number of people are in the home.



Away

Low air flow. Reduces the energy consumption when nobody is present in the home.



Travelling

Very low air flow and lower supply air temperature. Used when nobody is present in the home.

Automatic functions

The intelligent ventilation monitors the quality of the indoor air and adjusts the ventilation automatically.



RH Humidity 35%



Automatic RH system included as standard

Humidity automation removes damaging moisture. The intelligent control analyses the indoor air continuously and regulates the ventilation steplessly so that excess moisture is removed, for example when you are washing.



CO₂ Carbon dioxide 520 PPM



Automatic CO₂ system as optional equipment

Automatically lowers the ventilation and saves energy when nobody is in the home. When the residents are at home, the ventilation is automatically boosted to bring exactly the right amount of fresh air into the home.



VOC Air quality 950 PPM



Automatic VOC system as optional equipment

The automatic air quality system boosts the ventilation if pollution, odours or vapours (evaporating organic compounds) are detected in the indoor air.



Swegon CASA -liesikuvulta voi ohjata ilmanvaihtoa



Design data

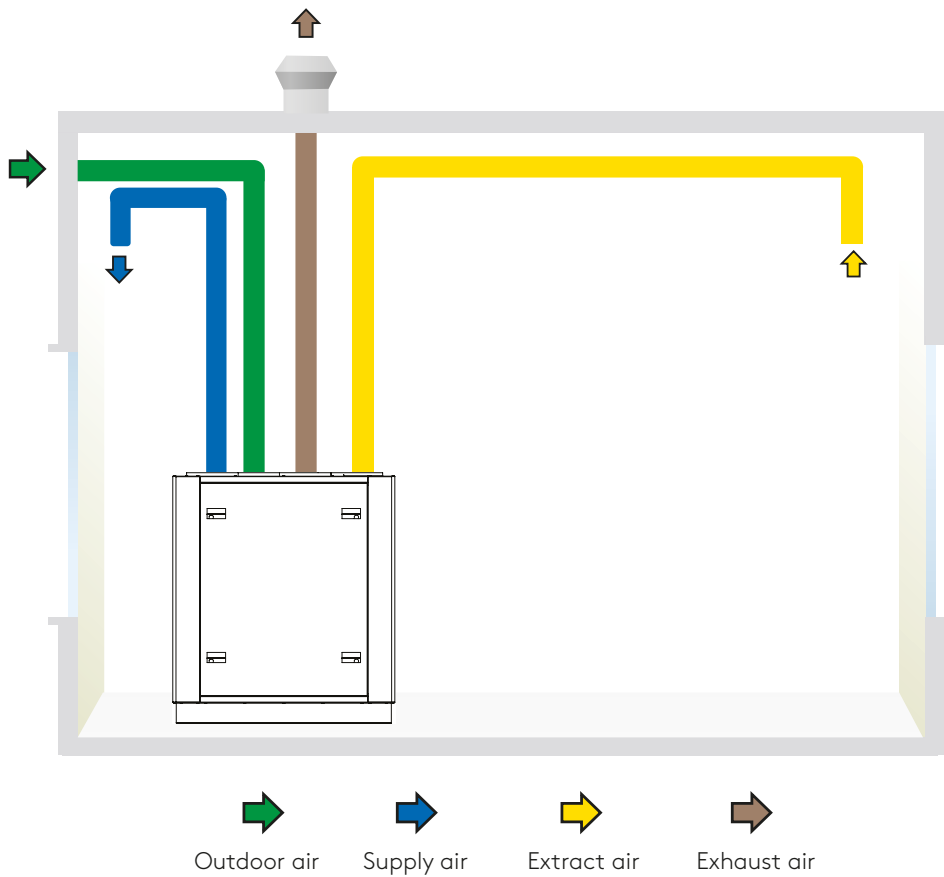

Note! Always check the correct duct sequence in the installation instructions.



ProCASA®

Energy calculation, functional diagram and acoustic data on ProCASA.

procasa.swegon.com



Energy calculator

Select area: FIN - Vantaa

EUROVENT CERTIFIED PERFORMANCE

Project: [Blank], Customer: [Blank], Designed by: [Blank], Location: [Blank]

Default values: Supply air 50 l/s, Extract air 50 l/s, Duct pressure 80 Pa, Cooker hood airflow 0 l/s, usage time per day 0 h/d

Indoor temperature 21°C, Minimum supply air temperature (+10°C, +21°C)

Additional accessories may be needed:

- SEC class: A
- SEC cold / average / warm class: A
- Max airflow rate: 331 m³/h
- Sound power level: 32 dB(A)

 This unit can be equipped with:

- Clock control*
- Central demand control*
- Local demand control*

Fan power and energy use EN15141-7

Supply air	31 W
Extract air	27 W
SFP	0.34 W / (m ³ /h)
SFP	1.16 kW / (m ³ /h)
Annual energy use of fans	508 kWh

Energy used to heat the air EN15141-7

Preheating	0 kWh
Reheating to 17 °C	237 kWh
Reheating the supply air to 21 °C	1243 kWh
Reheating the infiltrated air to 21 °C	0 kWh
Energy used to heat up ventilated air to 21°C	1481 kWh
Energy used without heat recovery	7114 kWh
Annual energy efficiency for room (21°C)	79 %
Reheating the infiltrated air to 17 °C	0 kWh
Energy used to heat up ventilated air to 17 °C	237 kWh
Annual energy efficiency for AHU (17 °C)	97 %

Acoustic data

Octave band (Hz)	63	125	250	500	1k	2k	4k	8k	L _{eq}
supply air duct	68	69	68	57	52	49	44	37	62
extract air duct	60	63	61	45	34	33	21	19	54
outdoor air duct	60	63	62	47	35	31	21	18	55
kitchen bypass duct	67	68	68	56	52	48	43	36	62
surroundings	50	44	45	37	28	19	12	11	39
surroundings or -4dB sound attenuation	L _{eq} dB(A) 35								

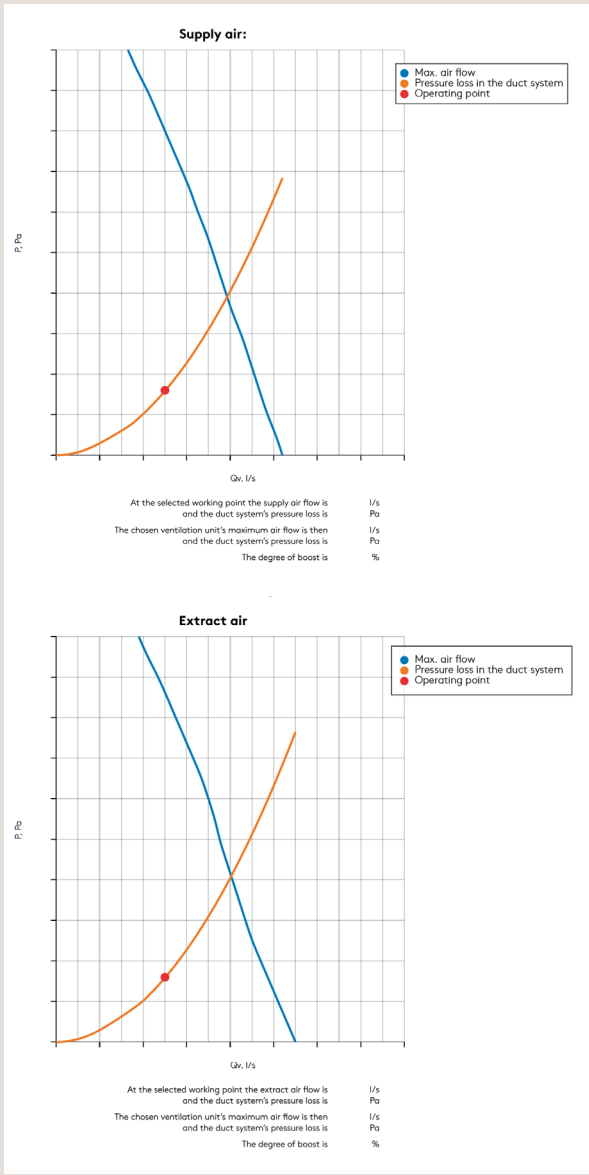

3D models and CAD dimension sketches for all Swegon CASA products are available from MagiCloud. You can download DXF files directly from MagiCloud or use a MagiCAD plugin to transfer dimension sketches to the Revit and AutoCAD software packages.

www.magicloud.com



Air flows

Air flows EN 13141-4

R15

- Supply airflow
- - - Extract airflow

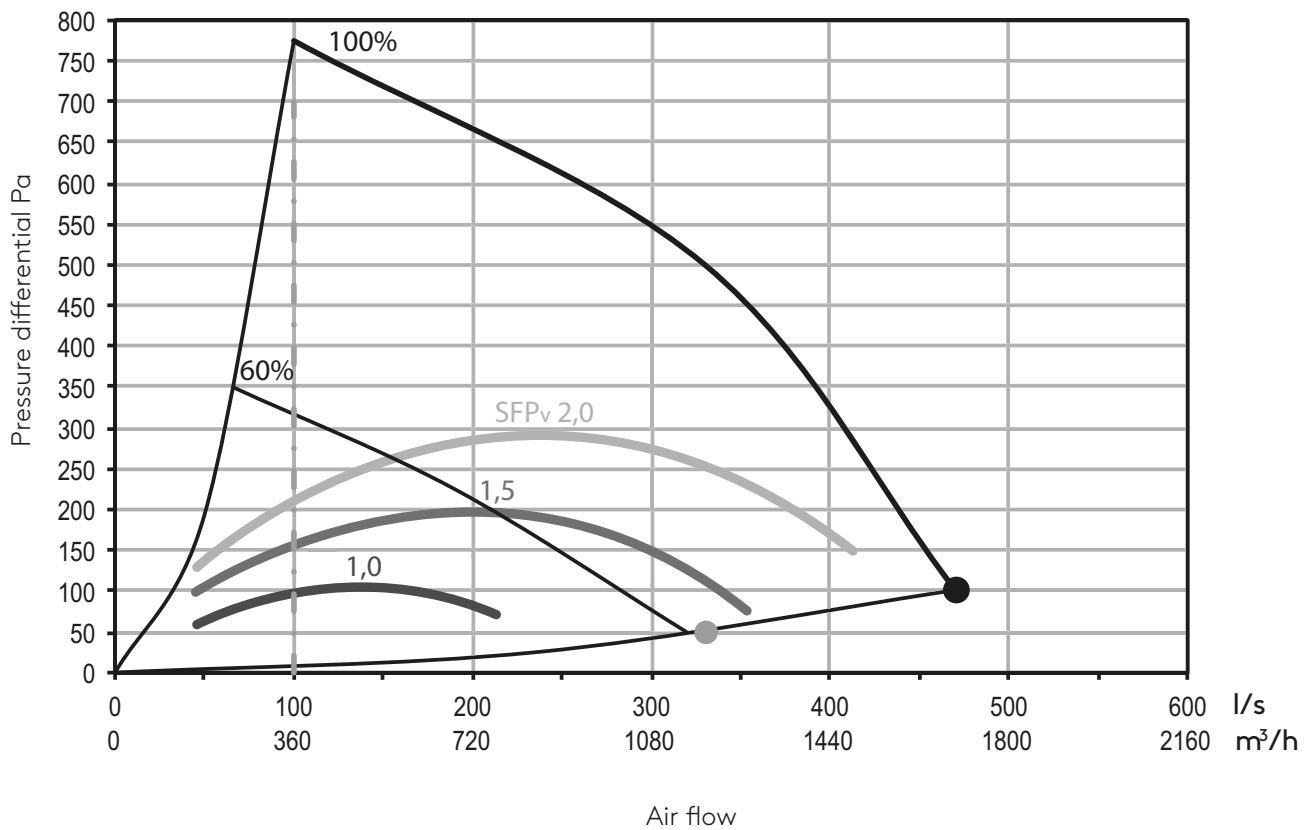

Acoustic data

See acoustic data on ProCASA.

procasa.swegon.com





Dimensions and weight

Dimensions

R15

Weight of the unit: **170 kg**

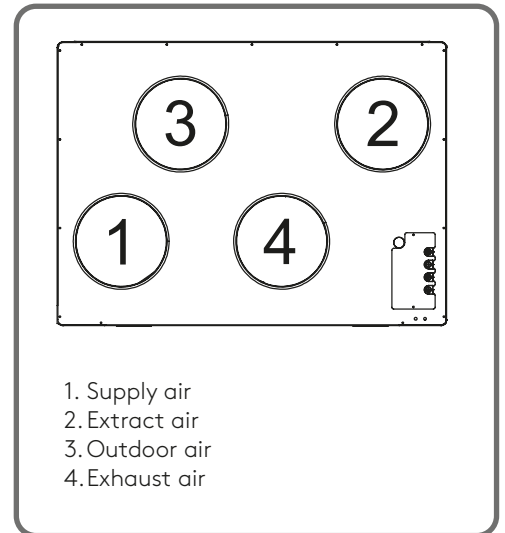
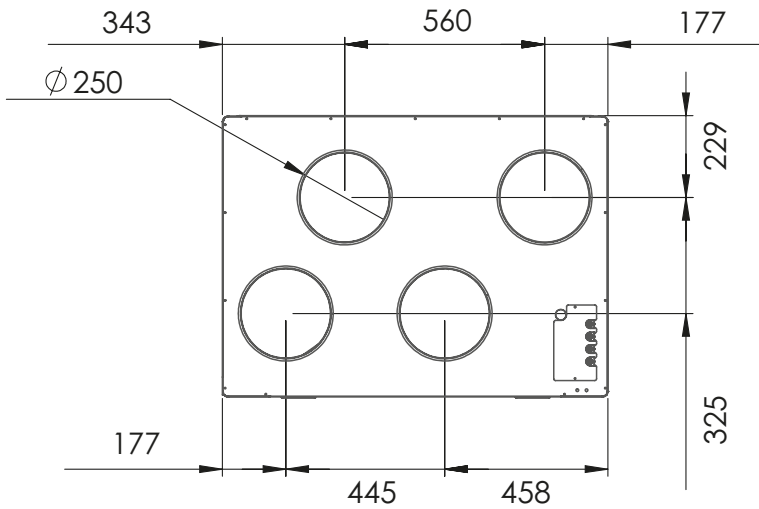
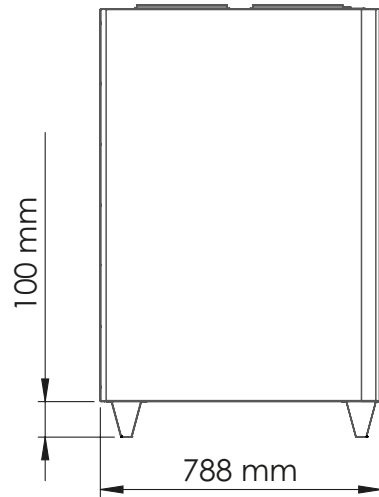
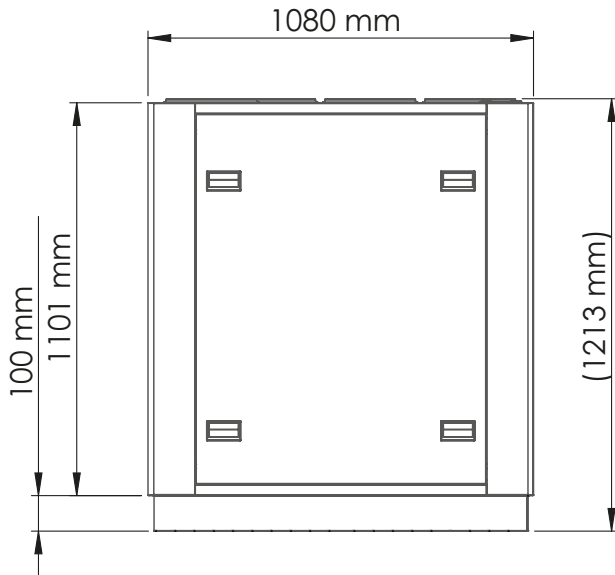



Functional diagram

Functional diagram

R15

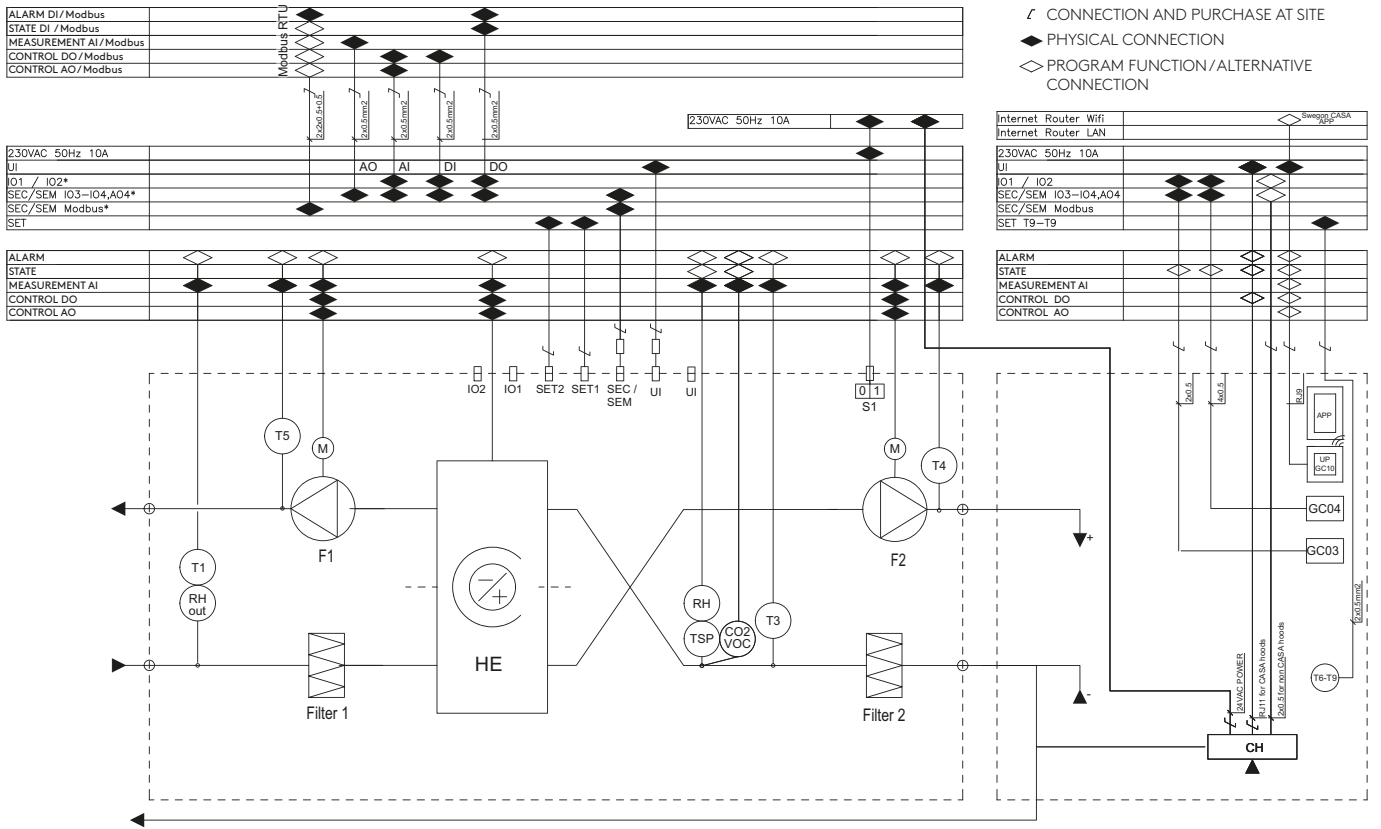

- CONFIGURATION AT SITE
- ◊ CONNECTION AND PURCHASE AT SITE
- ◆ PHYSICAL CONNECTION
- ◇ PROGRAM FUNCTION/ALTERNATIVE CONNECTION

Device	Description	Modbus register
T1	Temperature sensor, outdoor air	3x6201 (0,1°C)
T3	Temperature sensor, extract air	3x6204 (0,1°C)
T4	Temperature sensor, supply air	3x6203 (0,1°C)
T5	Temperature sensor, exhaust air	3x6205 (0,1°C)
Filter 1	Fresh air filters ISO ePM1 50% (F7)	Service reminder info 3x6129
Filter 2	Extract air filter ISO ePM1 50% (F7)	Service reminder info 3x6129
F1	Extract fan including internal overheat protection.	Control 3x6304(%), RPM 3x6306
F2	Supply fan including internal overheat protection.	Control 3x6303(%), RPM 3x6305
HE	Rotating heat exchanger (Rotor)	
HE M	A heat exchanger motor which speed is steplessly controlled based on the temperature and humidity of the supply air	Control 3x6332 (0.1xRPM)
S1	Use Switch. Note! power off the unit by removing the socket from the Mains when Service	
RH	Humidity sensor, Extract air	RH 3x6214
RH out	Humidity sensor, Outdoor air	
TSP	Extract air temperature sensor for humidity measurement	

Functional diagram Duct actuators

- FIELD CONFIGURATION AU
- ∠ FIELD CONNECTION SU
- ◆ PHYSICAL CONNECTION
- ◇ ALTERNATIVE CONNECTION (Note: an additional relay is required for DO outputs)

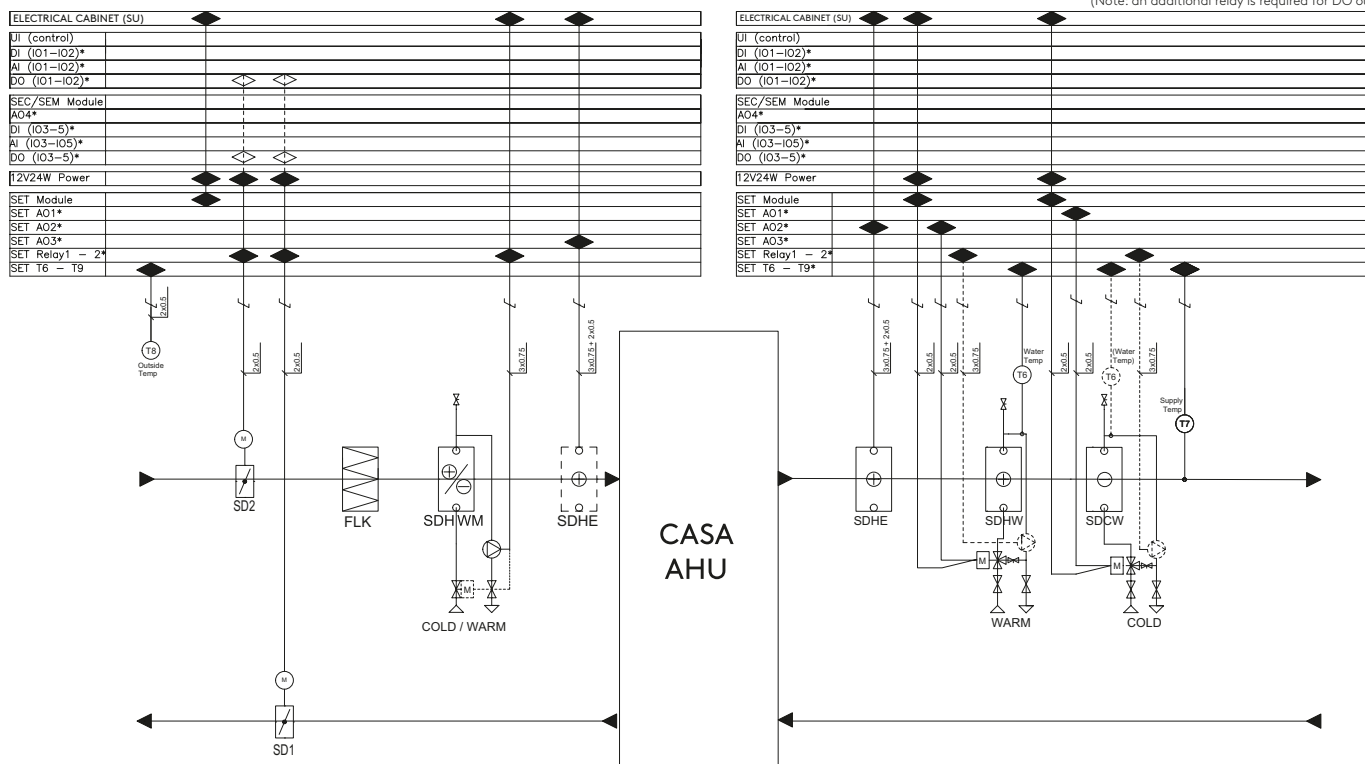

Device	Description
T6-T9	Temperature sensor. Connection to the SET module. The sensor must be defined on the control panel.
SD1, SD2	Duct Plate for Outdoor/Exhaust duct.
FLK	Duct filter in combination with an electric pre heater (SDHE)
SDHWM	Ground Liquid preheating/cooling coil for outdoor air duct. (Inc SET, heating/cooling coil, sensor)
SDHE	Electrical duct heater for Supply/Outdoor air duct (Inc. SET, duct heater and sensors) Note! A duct filter (FLK) is required for the preheater.
SDHW	Heating coil for supply air duct (Inc. SET, three-way valve + actuator, heating coil, sensors).
SDCW	Cooling coil for supply air duct (Inc. SET, three-way valve + actuator, cooling coil, sensors).
CO2	CO2 sensor for CO2 automation
VOC	VOC sensor for VOC automation
SEM	Modbus module (Inc. 2m RJ-45 cable)
SEC	IO extension module (Inc. 2m RJ-45 cable)
SET	Connection module for duct batteries and temperature sensors. (Inc. 2 x 3m RJ-45 cable)
APP	Swegon CASA mobile application for ventilation control and monitoring. Requires a Genius control panel (GC10) to operate.
UP GC10	Genius control panel that can be connected to Swegon CASA application via WiFi.
GC04	Control switch to select boost, home and away mode.
GC03	Control switch to select boost mode.
CH	Cooker hood. The CASA hood is connected to the ventilation unit with a modular cable. With other hoods, you can control the cooking function with a switch input that is determined for the function.



External connections

External connections CASA Genius

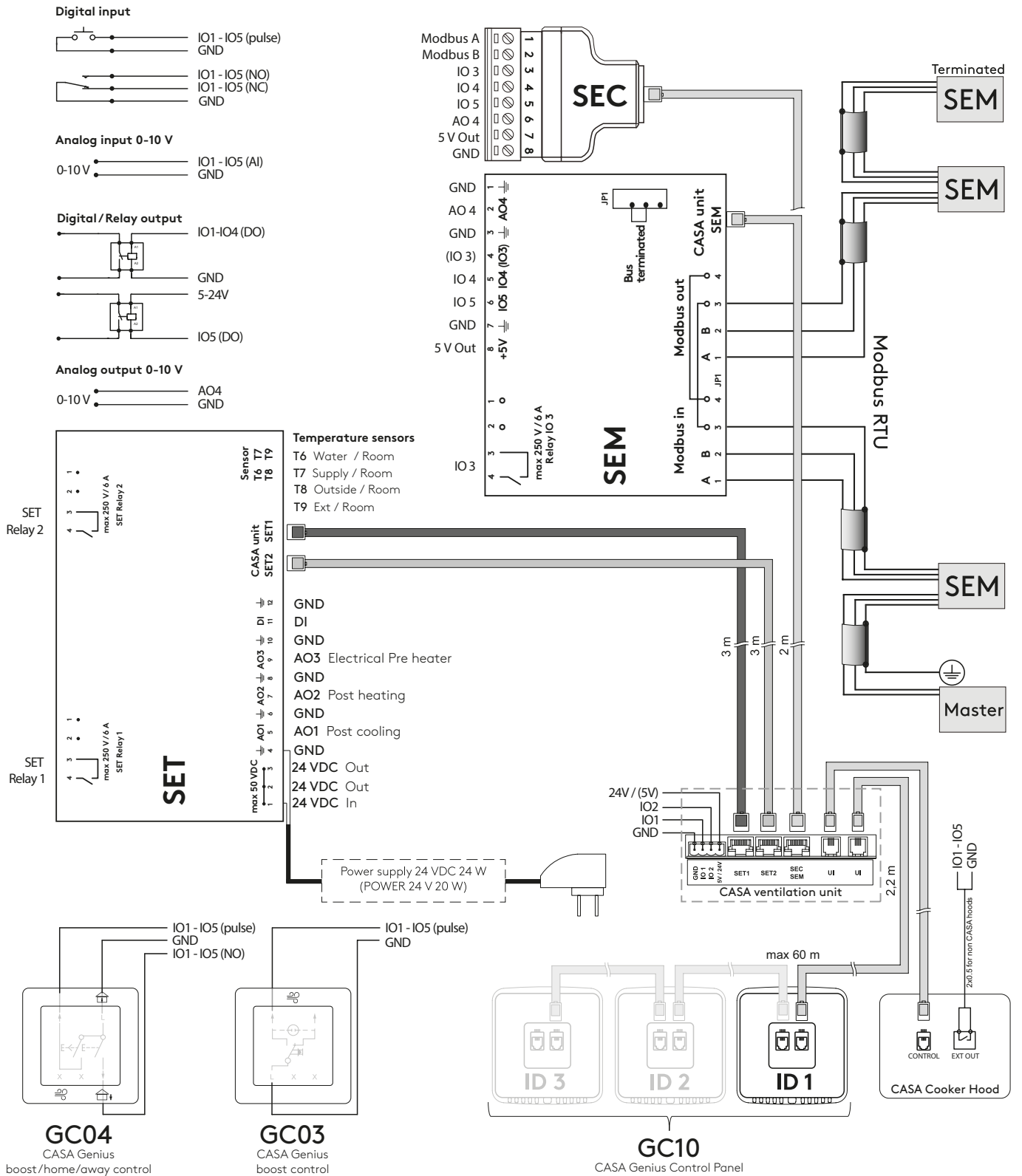

- SEC** IO extension cable with Modbus RTU
- SEM** IO extension module with relay and Modbus RTU (input and output connections)
- SET** IO extension module for control of external accessories

Internal connections

R15

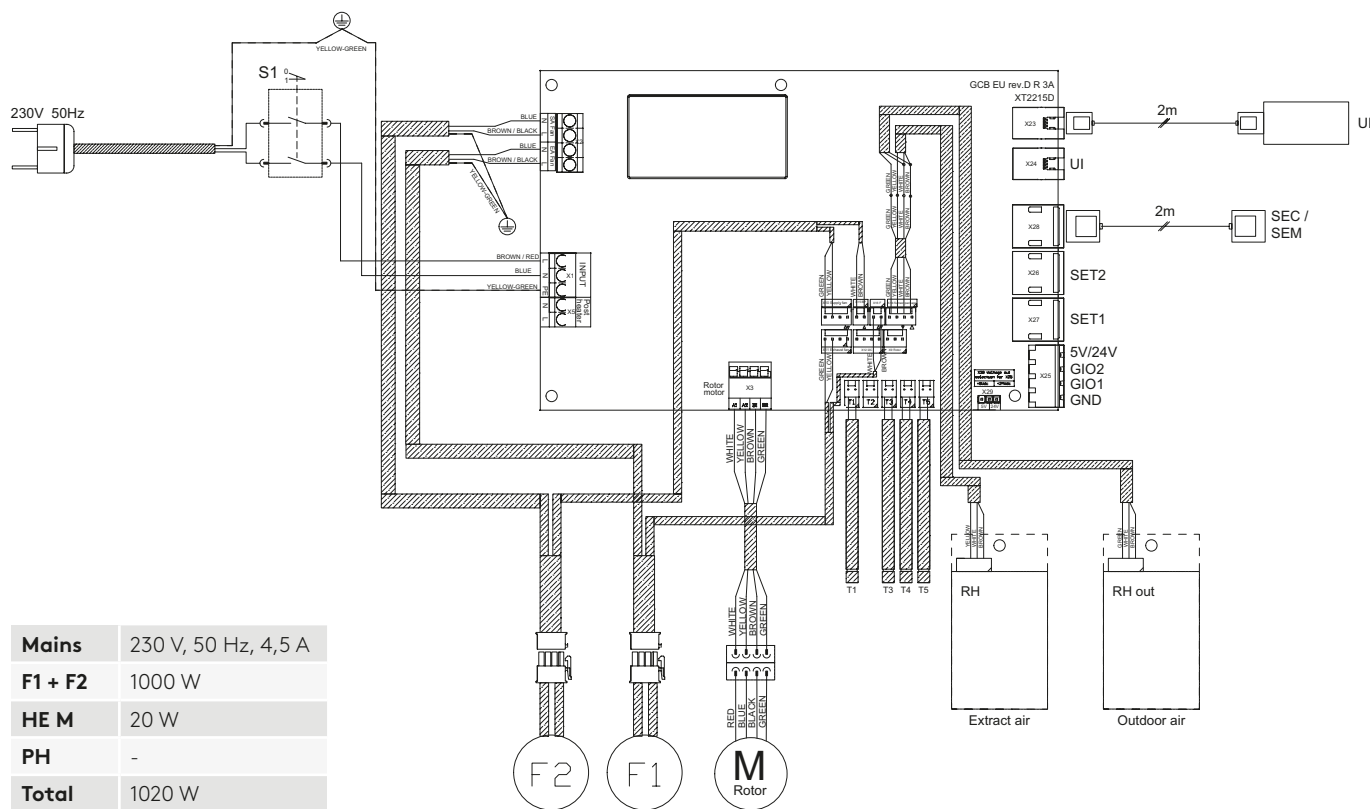

Mains	230 V, 50 Hz, 4,5 A
F1 + F2	1000 W
HE M	20 W
PH	-
Total	1020 W

Device	Description
T1	Temperature sensor, outdoor air
T3	Temperature sensor, extract air
T4	Temperature sensor, supply air
T5	Temperature sensor, exhaust air
F1	Extract fan including internal overhear protection.
F2	Supply fan including internal overhear protection.
HE M	A heat exchanger motor which speed is steplessly controlled based on the temperature and humidity of the supply air
S1	Use Switch. Note! power off the unit by removing the socket from the Mains when Service
RH	Humidity sensor, Extract air
RH out	Humidity sensor, Outdoor air
TSP	Extract air temperature sensor for humidity measurement
CO2	CO2 sensor for CO2 automation (accessory)
VOC	VOC sensor for VOC automation (accessory)
UI	Connectors for connecting the control panel and/or CASA cooker hood. One connection point is wired outside the unit.
SEC/SEM	Connector for connecting the SEC or SEM module.
SET 1&2	Connectors for connecting the SET module
5V/24V	24V voltage output, which can be changed to 5V output with a jumper on the circuit board.
IO 1&2	Two general-purpose IO connectors. Connectors must be configured for the desired functions.
GND	Ground for IO connections.



Installation options

Ventilation unit installation site

Due to the risk of disruptive noise, the ventilation unit should not be installed on the wall towards the living room or bedroom.

Note! Unit has no condensation drain. Therefore it's not suitable in houses where unit's extract air humidity may be high. (i.e. sauna, spa, etc.)

Mounting on the floor

The unit should be installed on the floor. The device is heavy. Make sure that the mounting base will withstand its weight.

The rear edge of the unit must be at least 50 mm off the wall.

Free space in front of the maintenance door of the unit must be at least 1200 mm and above the electrical box at least 300 mm.





Product codes

R15

Product	Product code	GTIN
CASA R15 Genius L ex.el RH sorption	R15VL00G00HAS	6430080091232



CASA R - Accessories

Control accessories	Part no.	GTIN
GC10 CASA Genius control panel and WiFi	GC10	6430080090846
GC10 control panel + 10 m long cable	GC14	6430080090853
GC10 control panel + 10 m long cable + frame	GC15	6430080090860
GC10 control panel + frame	GC16	6430080090877
Frame for control panel GC10	102SAK	6415879066752
CASA Genius boost/home/away control button	GC04	6430080090013

Building automation	Part no.	GTIN
Modbus connection module	SEM	6415879067346
Connection cable (configurable I/O) for Genius ventilation units	SEC	6415879067353
Room temperature sensor.	WSTC	6415879069395

Automatic functions	Part no.	GTIN
RH + CO2 automation	SRHCO2	6415879066936
RH + VOC automation	SRHVOC	6415879066943

Waterborne air coolers	Part no.	GTIN
Cooling coil package Ø 250	SDCW250	6415879070025

Waterborne air heaters	Part no.	GTIN
Heating coil package Ø 250	SDHW250	6415879070032

Brine air heater/cooler for ground source heat pump	Part no.	GTIN
Heating/cooling coil Ø 250, G4	SDHW250F	6415879068084

Electric air heater	Part no.	GTIN
Electric heater Ø 250, 1,2 kW	SDHE250-1T	6415879068954
Electric heater Ø 250, 2,0 kW	SDHE250-2T	6415879068961
Electric heater Ø 250, 3,0 kW	SDHE250-3T	6430080091096
Prefilter box Ø 250 mm, G4	FLK25	6415879068992

Duct mounted shut-off dampers	Part no.	GTIN
Damper Ø 250 mm	SDD250	6415879070056

Other accessories	Part no.	GTIN
Connection module for control of the duct mounted air heater/cooler / control of shut-off dampers	SET	6415879067339
SET / power source for actuators	POWER24V20W	6415879068404
PTH Regulation for constant duct pressure	PTH	6415879067285

Feel good **inside**



Swegon 