

# ADAPT Parasol EXb

Installation - Commissioning - Maintenance

20/04/2021

Art. 942428024

## Content

<b>Installation, base module</b> .....	<b>2</b>
Water .....	4
Air .....	5
<b>Commissioning</b> .....	<b>5</b>
Nozzle setting .....	5
ADC .....	7
<b>Connections</b> .....	<b>8</b>
<b>Installation, design cover</b> .....	<b>11</b>
<b>Maintenance</b> .....	<b>14</b>

### Symbols in this user manual

Warning/Caution!



# Installation, base module

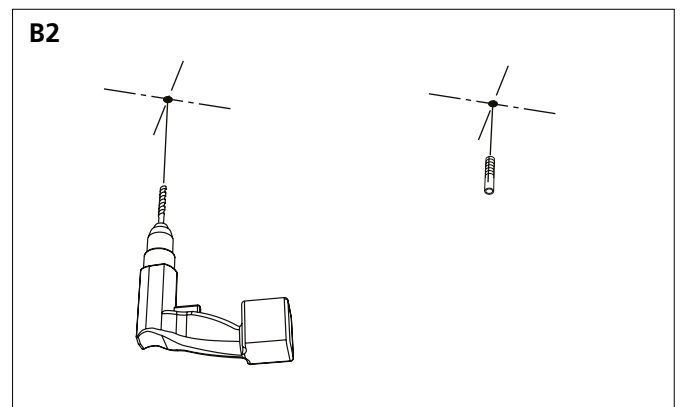
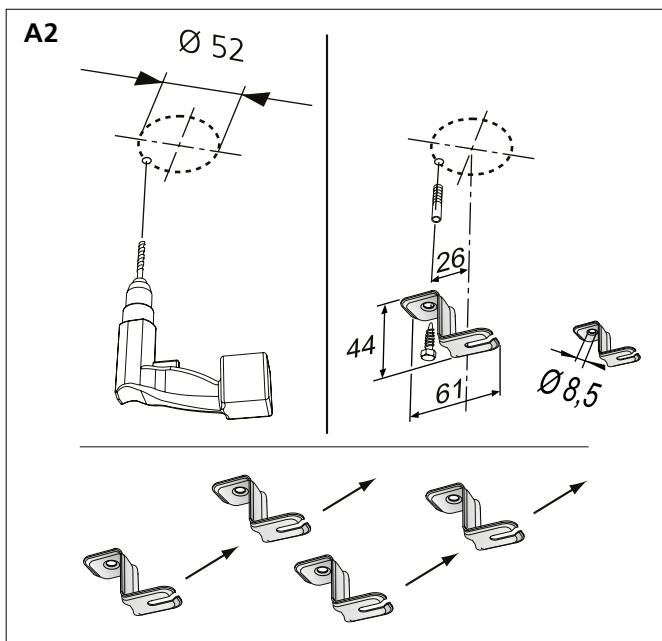
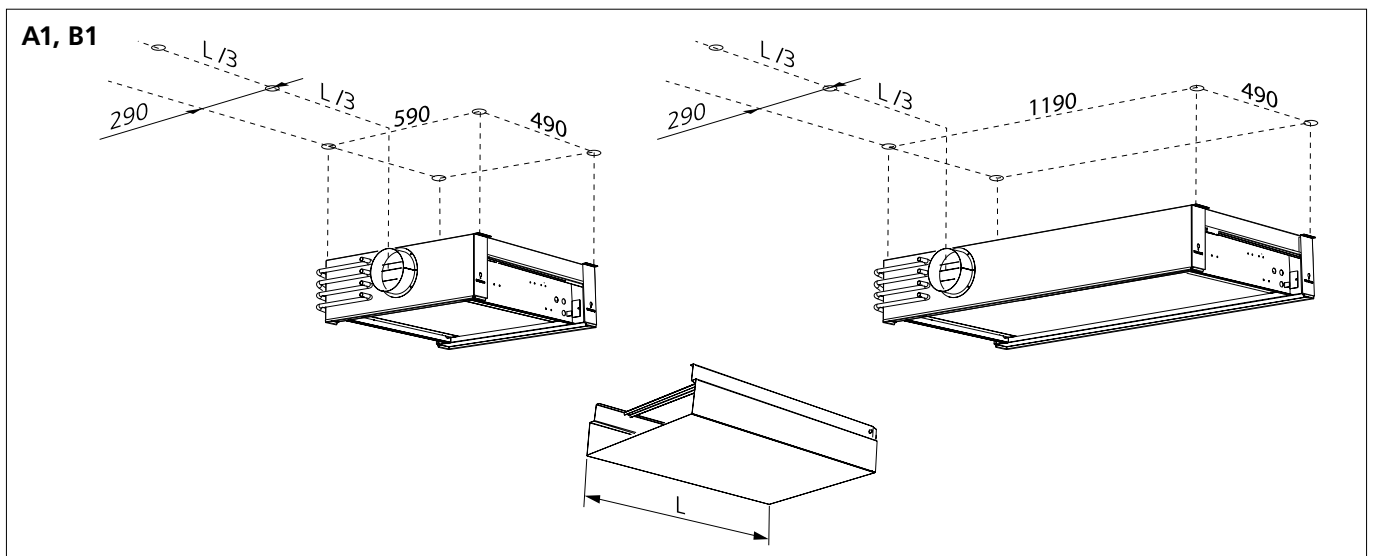
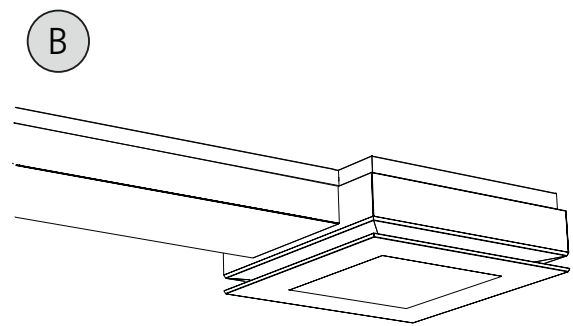
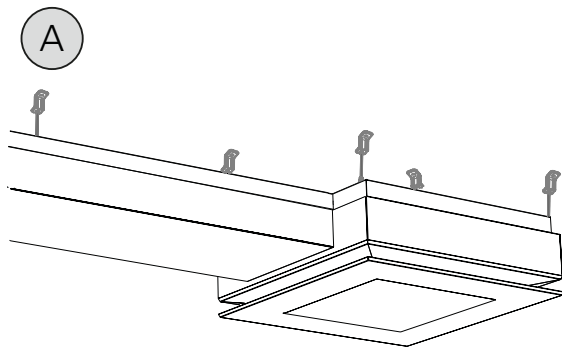

A3, B3

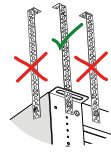
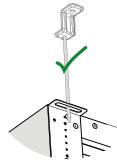

A4

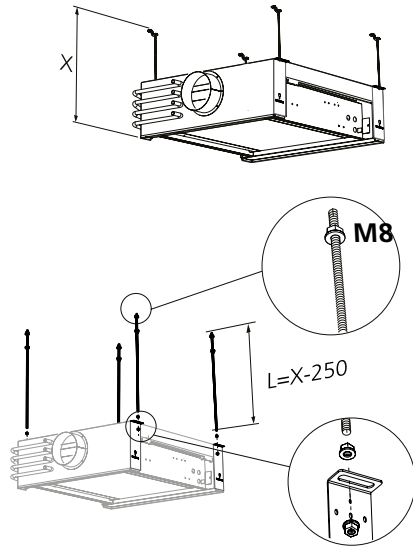

B4

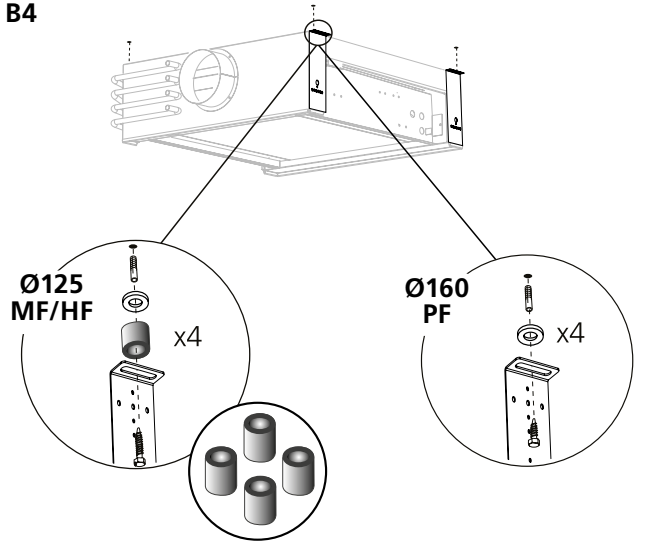

A5

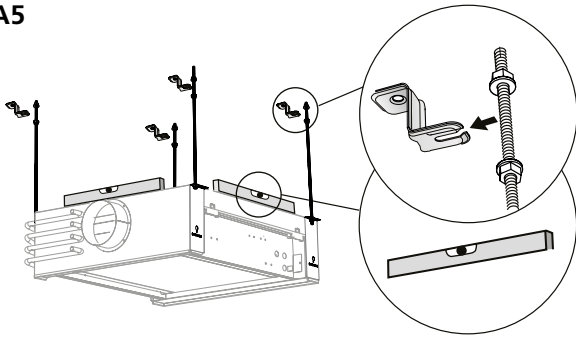

B5

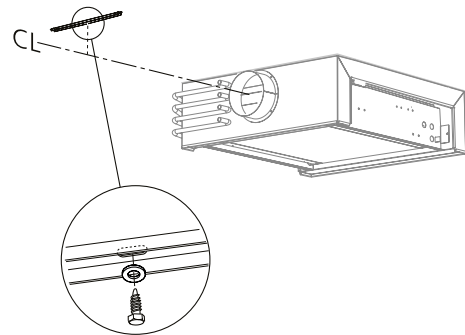

A6

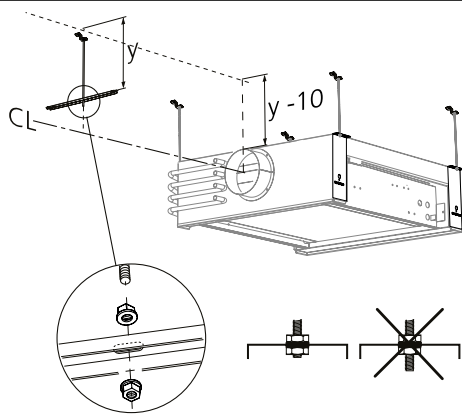

A7, B6

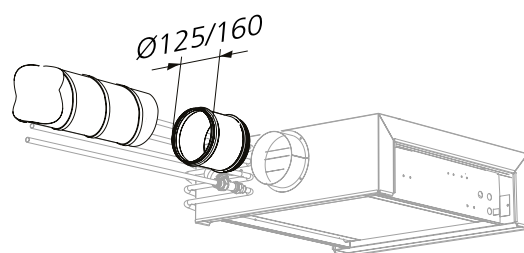

## Water

### Water connection

EX 690	EX 1290	EX 1290 Left - side 4
Värme retur/ Heating return <b>B2</b>	Värme retur/ Heating return <b>B2</b>	Värme tillopp/ Heating supply <b>B1</b>
Värme tillopp/ Heating supply <b>B1</b>	Kyla tillopp/ Cooling supply <b>A1</b>	Kyla retur/ Cooling return <b>A2</b>
Kyla tillopp/ Cooling supply <b>A1</b>	Värme tillopp/ Heating supply <b>B1</b>	Värme retur/ Heating return <b>B2</b>
Kyla retur/ Cooling return <b>A2</b>	Kyla retur/ Cooling return <b>A2</b>	Kyla tillopp/ Cooling supply <b>A1</b>

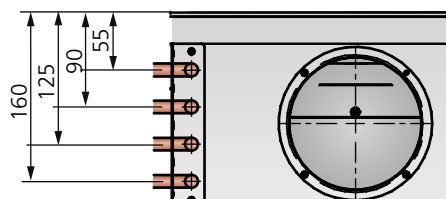

### Valve kit installation

If the product is ordered with valve kits, these are supplied connected to the regulator and temporarily attached using cable ties.

- Cut the cable ties (A) and mount the valve kit on the pipes for cooling return and heating return according to the product variant in question.
- Mount the valve kit so that the actuators are aligned as illustrated in the figure below.

### Placement of the valve kit on delivery

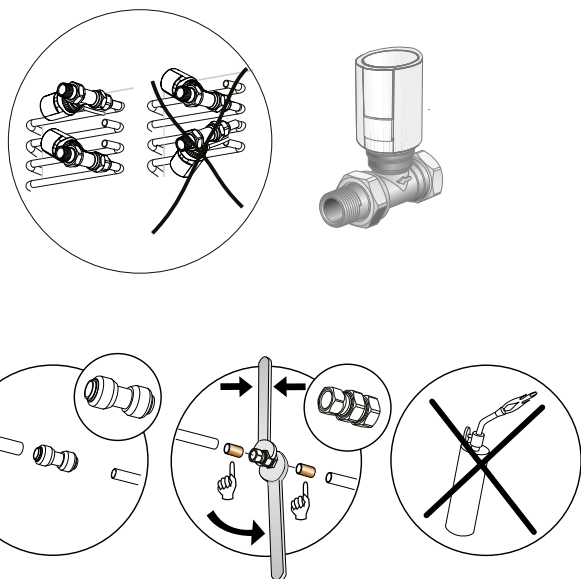
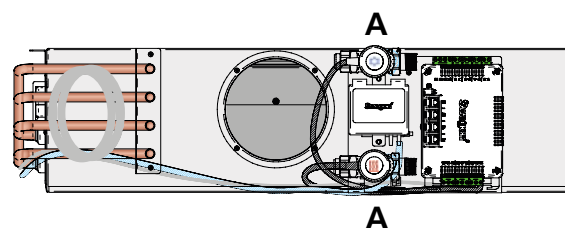

### Air and water connections on side 2 (standard)

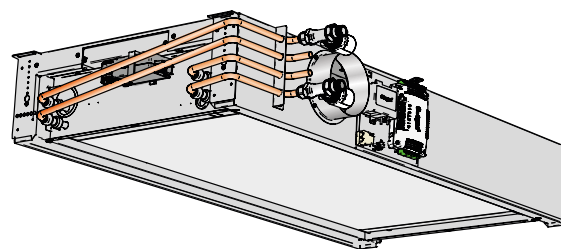

### Air and water connections on side 4

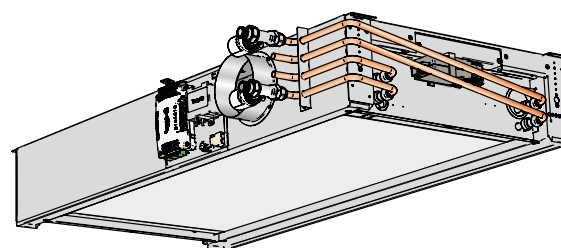

Note that compression ring couplings require support sleeves inside the pipes.

### Connection sizes

Model	Size	Supplied / Connected	Connection	Coupling type	Connection	Coupling type
A: only Cooling	690, 1290	Actuator and valve	Return	DN15, male thread	Supply pipe	Plain pipe 12 x 1.0 mm
B: Cooling/Heating	690, 1290	Actuator and valve	Return	DN15, male thread	Supply pipe	Plain pipe 12 x 1.0 mm
A: only Cooling	690, 1290	-	Return	Plain pipe 12 x 1.0 mm	Supply pipe	Plain pipe 12 x 1.0 mm
B: Cooling/Heating	690, 1290	-	Return	Plain pipe 12 x 1.0 mm	Supply pipe	Plain pipe 12 x 1.0 mm



# Air

## Connection dimensions

Unit	Ø =
ADAPT Parasol EX 690 MF/HF	Ø 125
ADAPT Parasol EX 690 PF	Ø 160
ADAPT Parasol EX 1290 MF/HF	Ø 125
ADAPT Parasol EX 1290 PF	Ø 160

### Air connection on side 2 (standard)

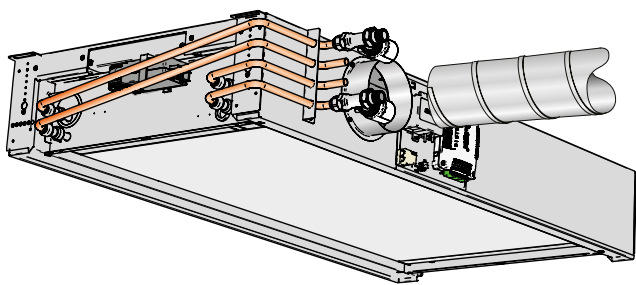

### Air connection on side 4

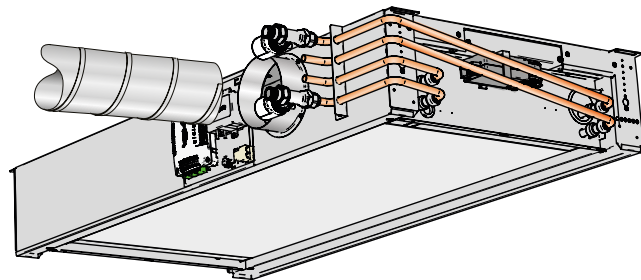

# Commissioning

## Nozzle setting

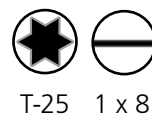
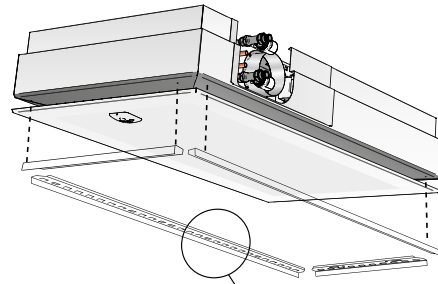

### Nozzle configuration

H → M → L

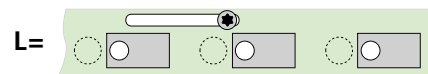
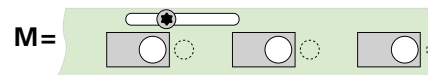
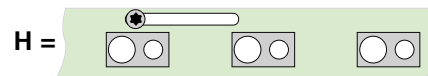

$$p_i = \left(\frac{q}{k}\right)^2 \text{ [Pa]}$$

$$q = k \cdot \sqrt{p_i} \text{ [l/s]}$$

[p<sub>i</sub> Pa]  
q [l/s]  
k = k-factor

## k-factor guide per side

Type	Primary air volume	Side	Nozzle setting	k-factor / side
690	Low	1,2,3,4	L	0.253
690	Average	1,2,3,4	M	0.44
690	High	1,2,3,4	H	0.693
690	None	1,2,3,4	C	0
1290 MF	Low	1&3	L	0.176
1290 MF	Average	1&3	M	0.253
1290 MF	High	1&3	H	0.429
1290 MF	None	1&3	C	0
1290 MF	Low	2&4	L	0.464
1290 MF	Average	2&4	M	0.667
1290 MF	High	2&4	H	1.131
1290 MF	None	2&4	C	0
1290 HF	Low	1&3	L	0.253
1290 HF	Average	1&3	M	0.44
1290 HF	High	1&3	H	0.693
1290 HF	None	1&3	C	0
1290 HF	Low	2&4	L	0.667
1290 HF	Average	2&4	M	1.16
1290 HF	High	2&4	H	1.827
1290 HF	None	2&4	C	0
1290 PF	Low	1&3	L	0.85
1290 PF	Average	1&3	M	0.99
1290 PF	High	1&3	H	1.21
1290 PF	None	1&3	C	0
1290 PF	Low	2&4	L	2.22
1290 PF	Average	2&4	M	2.62
1290 PF	High	2&4	H	3.2
1290 PF	None	2&4	C	0

### Side 1-4, (standard connection on side 2)

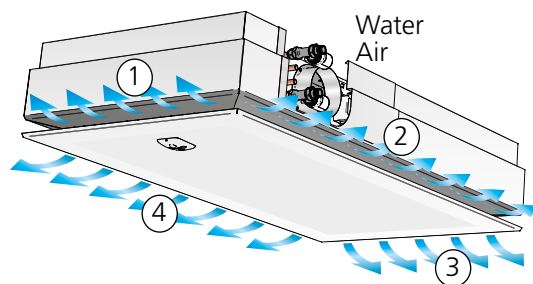

### Side 1-4, (left-hand connection on side 4)

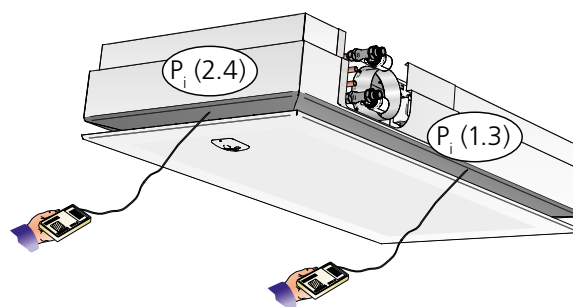
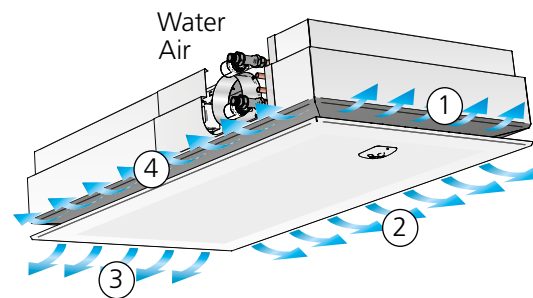

- ①  $k(1+3) + p_i(1.3) \Rightarrow q(1+3)$   
K-factor of the short sides together with the commissioning pressure reading of these equals the flow of the short sides, 1&3.
- ②  $k(2+4) + p_i(2.4) \Rightarrow q(2+4)$   
K-factor of the long sides together with the commissioning pressure reading of these equals the flow of the long sides, 2 & 4.
- ③  $q_{tot} = q(1+3) + q(2+4)$   
The total flow of the product is the sum of the above.

**NB!  $p_i(1.3) \neq p_i(2.4)$**

**NOTE: The commissioning pressure is different for the long sides (2 & 4) and the short sides (1 & 3).**

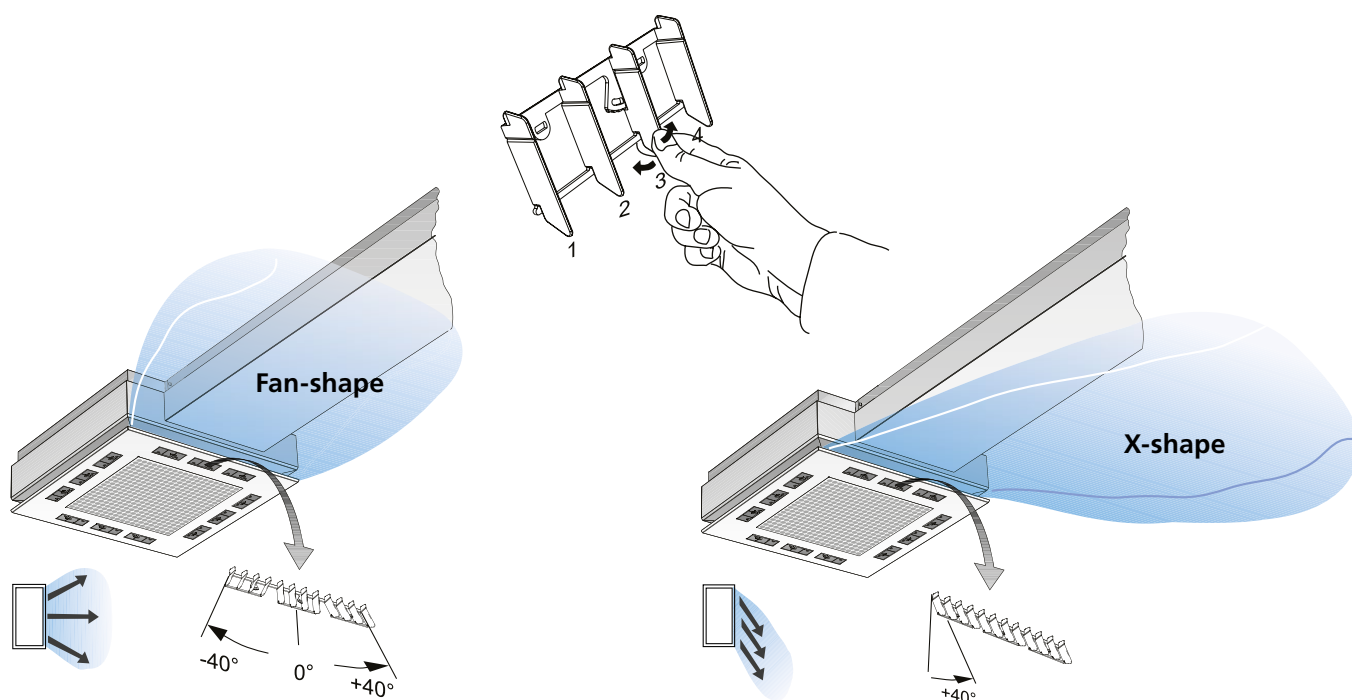

## Commissioning/checking the air flows

Constant pressure in the zone with the CONTROL Zone damper or similar damper.

- Check that all WISE gen.1 products are energised.
- Make sure that all ADAPT Parasol EX-modules have their correct K-factors.
- Make sure that all the modules are set to the max. flow commissioning mode. (On delivery, the product is set to this mode, 3 blue LEDs + 3 red LEDs are lit).
- Connect up to the control unit on the ADAPT Parasol EX (see separate SWICCT instructions) and carry out a performance check.
- Test the operating modes, the min./max. flows, open/close the actuators. If the ADAPT Parasol EX has been configured at the factory, check that the settings agree with the project design data. If the module is an ADAPT Parasol EX stock (stocked product), it must be programmed according to the data for which the product has been calculated. Make also sure that the Modbus addresses agree if SuperWISE or some other BMS system will be used
- If SuperWISE will be used, make sure that all products are in the SuperWISE tree structure. If all the products are not in the tree structure, look over the Modbus addresses via SWICCT and check cables and connections. (See the separate instructions for the SuperWISE)
- Make sure that the pressure sensor and sensor module have the correct Modbus address. The Master must have a 0 setting on the pressure sensor and sensor module. Set the Slaves, if required, in number sequence: 1, 2, 3, 4, 5, 6, 7, 8, 9
- Before you begin commissioning, make sure that the air handling unit is started up and the fire damper, if required, is fully open and that the zone damper is fully operational.
- Check the flow compared to the max. flow in the zone, adjust the pressure set point until the correct flow is obtained with TUNE Control. If Max. flow is not achieved, it will be necessary to close another/other zone damper(s).
- The reference product can be found, i.e. the one with the greatest deviation from the design max. flow, by measuring the max. flow of all the ADAPT Parasol EX-modules in the zone.
- Measure and record the airflow with the damper set to the max. position on the reference ADAPT Parasol EX in the zone. Reset the module to the min. flow setting, measure and record the airflow.
- Set the module back to the max. flow setting
- Carry out the same procedure for all the ADAPT Parasol EX-modules in the zone.
- Decrease the pressure set point on the zone damper if pressure is needed for other zones, for example: 5 Pa
- Commission the remaining zones following the same procedure
- Check/ adjust the previous shut off zones in the same way
- Restore the pressure set points on all the zone dampers.
- Identify the reference zone, i.e. the zone with the lowest flow compared with the design max. flow (for example by checking relevant flow across each zone damper using the TUNE Control hand-held terminal).
- Set the min. flow on a number of ADAPT Parasol EX-modules or use the zone damper for setting the min. flow so that the ventilation system responds to the simultaneous load.
- Adjust the pressure set point of the air handling unit until the zone damper of the reference zone is 85 – 90% open. (Managed by the SuperWISE if one is used).
- Reset all the settings and set all the ADAPT Parasol EX to the normal operation setting.
- Check and measure the max. flow and min. flow with the SWICCT or the SuperWISE.

# Connections

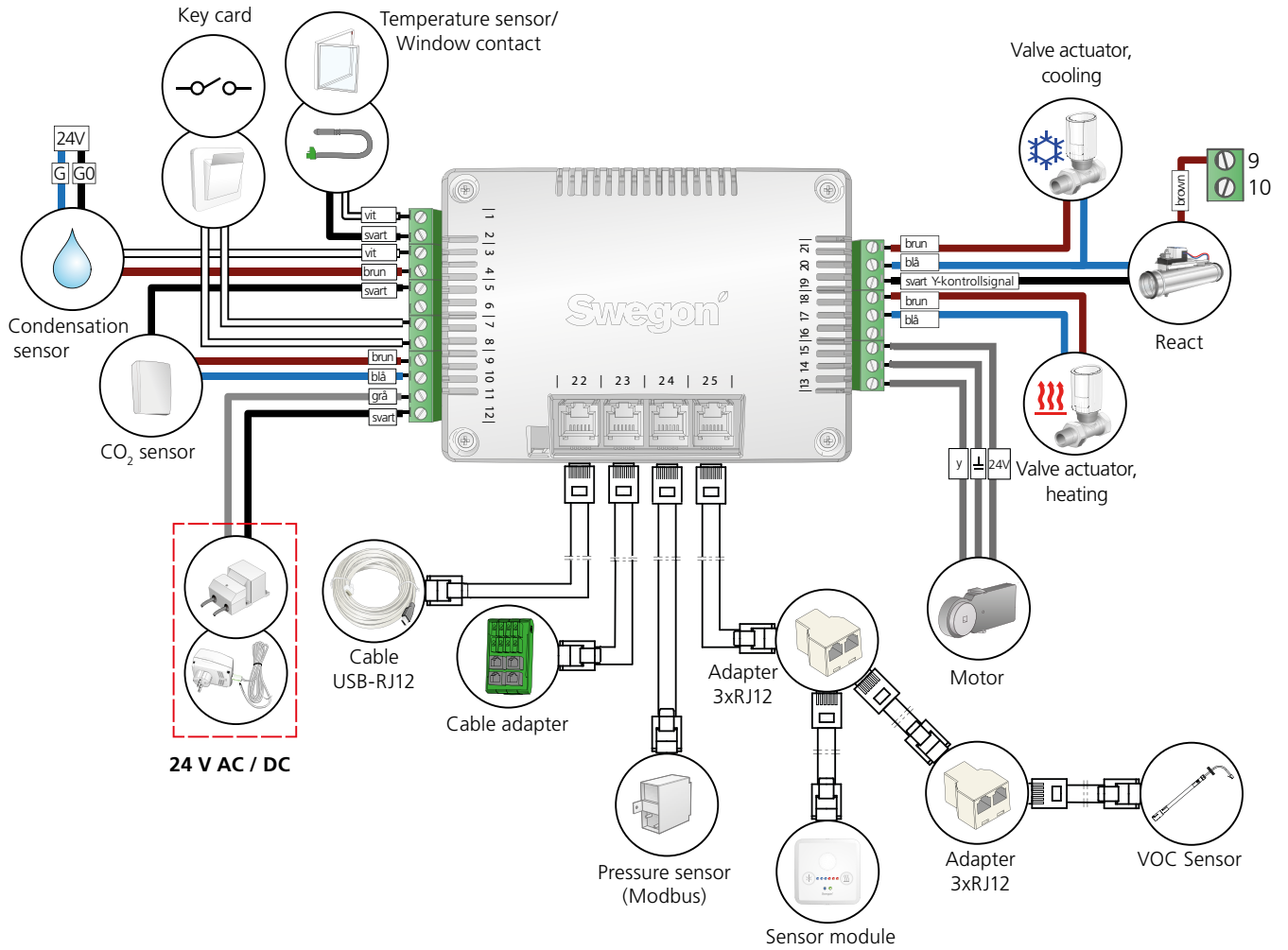

1. Connection when no VOC sensor is used.
2. Connection when a VOC sensor is used.

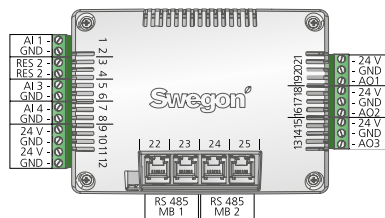

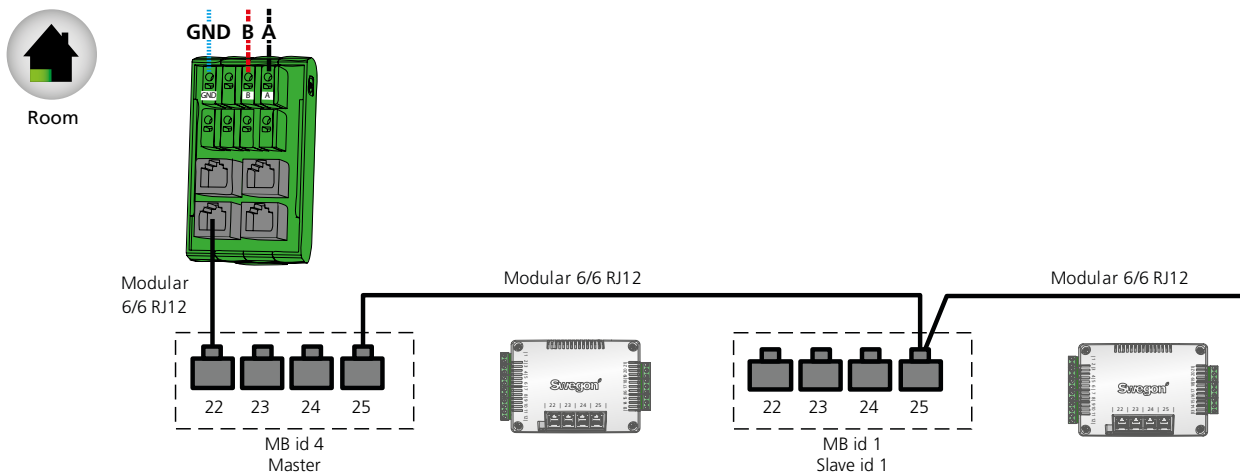
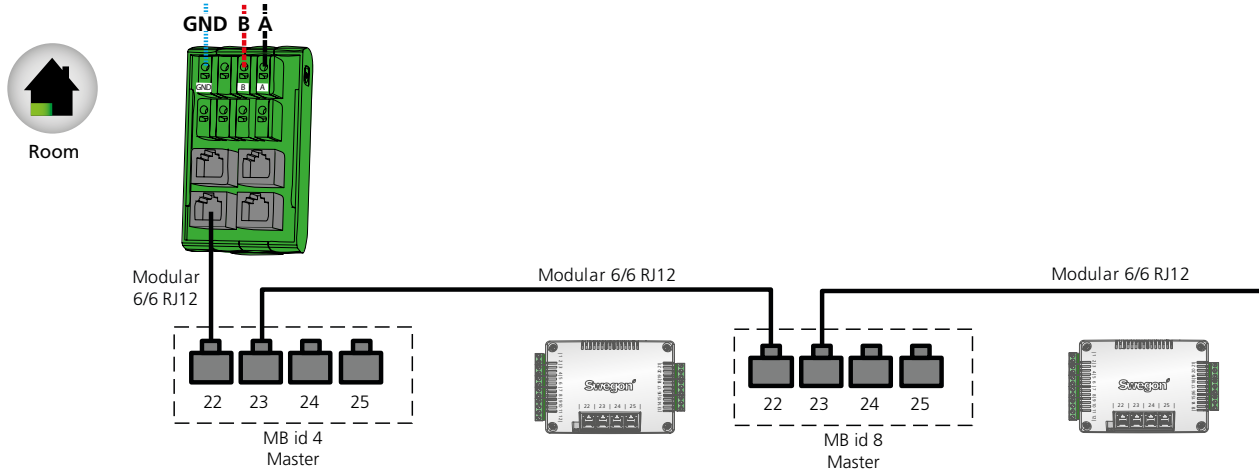
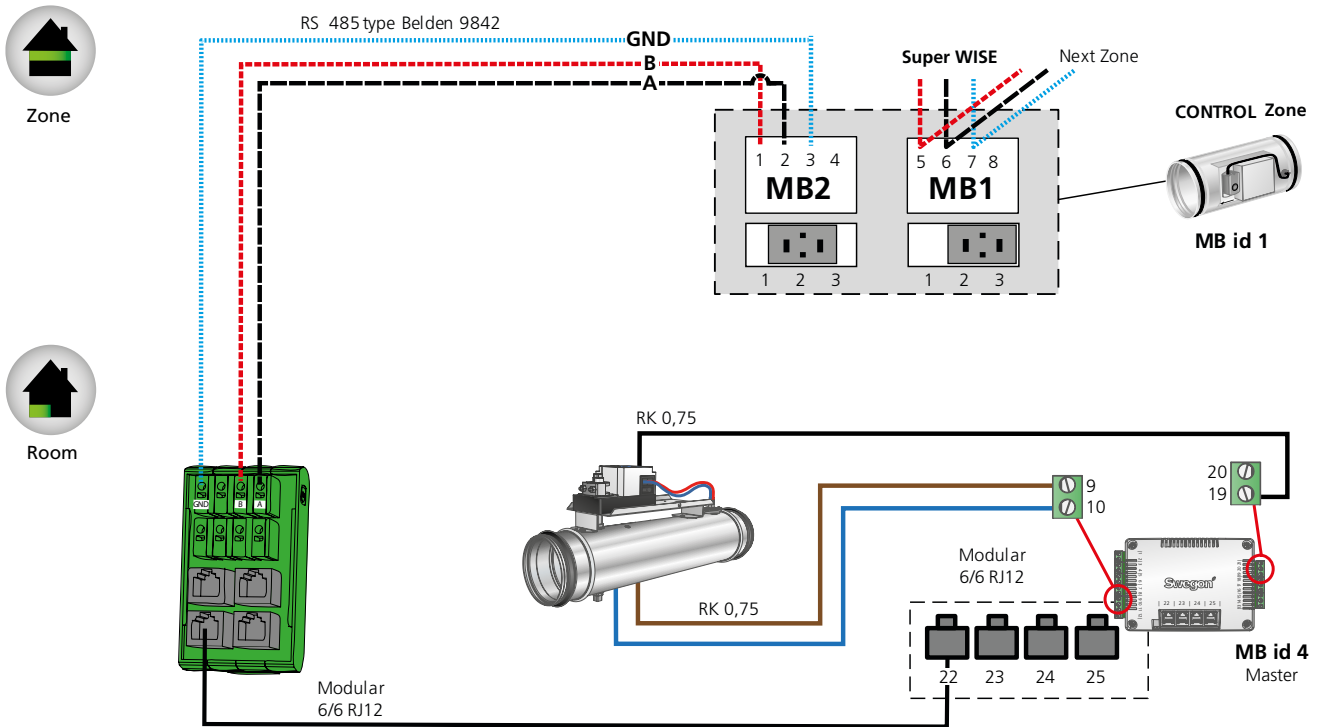

**Menu sensor module:**

Press and hold the left and right-hand buttons for five seconds to access the menu.

Use the left-hand button ( \* ) to steps through the menus. Use the right-hand button ( ⏏ ) to confirm your selection.

- Press the left-hand button and select:
- 1. Alarm list
- 2. Commissioning air
- 3. Commissioning water
- 6. Return to menu



Confirm selections by pressing the right-hand button

**1. Alarm list:** See the complete alarm list to the right. In the commissioning menus:

- Navigate between the menus by pressing the left-hand button
- Confirm selections by pressing the right-hand button
- When a selection has been confirmed, the blue LED will flash for about 60 seconds.
- In order to return to normal operation, select "no adjustment"

**2. Commissioning, air:**

- 2.1. Min. airflow, no occupants      ○ ● ○ ○ ○ ○
- 2.2. Min. airflow, occupancy          ● ○ ○ ○ ○ ○
- 2.3. Max. air flow, occupancy        ● ● ● ● ● ●
- 2.4. Min. airflow, holiday/longer period of no occupancy      ○ ○ ● ● ○ ○
- 2.5. No adjustment                      ○ ○ ○ ○ ○ ○

**3. Commissioning, water:**

- 3.1. Open the chilled water valve      ● ● ● ○ ○ ○
- 3.2. Open heated water valve          ○ ○ ○ ● ● ●
- 3.3. No adjustment                      ○ ○ ○ ○ ○ ○

**4, 5 are not used**

**6. Return to menu**

**Alarm list for the sensor module**

Alarm no.	Type of alarm	32	16	8	4	2	1
Alarm 1	Supply voltage low						●
Alarm 2	Supply voltage critical low					●	
Alarm 3	Ext temp missing					●	●
Alarm 4	Ext temp error				●		
Alarm 5	Condensation sensor error				●		●
Alarm 6	SM temp sensor error				●	●	
Alarm 7	SM button error				●	●	●
Alarm 8	CO <sub>2</sub> sensor missing			●			
Alarm 9	VOC Error			●			●
Alarm 10	Low pressure			●		●	
Alarm 17	SM comm error		●				●
Alarm 18	Slave comm error		●			●	
Alarm 19	Pressure sensor comm error		●			●	●
Alarm 20	VOC sensor comm error		●		●		
Alarm 21	No master request (slave)		●		●		●
Alarm 22	Slave incompatible version		●		●	●	
Alarm 25	Heating comfort alarm		●	●			●
Alarm 26	Cooling comfort alarm		●	●		●	
Alarm 27	Temp. Set point overlap alarm		●	●		●	●
Alarm 28	Air quality comfort alarm		●	●	●		
Alarm 29	Condensation		●	●	●		●
Alarm 33	24 V Out 1 overload error	●					●
Alarm 34	24 V Out 2 overload error	●				●	
Alarm 35	24 V Out 3 overload error	●				●	●
Alarm 41	Slave input sum alarm	●		●			●
Alarm 42	Slave output sum alarm	●		●		●	

The alarm is shown with a number of LEDs when you select Alarm list (1) in the menu.

Each LED represents a number as per the table above and the numbers are added to form an alarm number.

E.g. Middle blue and the two last red are lit (xoxoo)

Middle blue corresponds to 16, next last red 2 and last red 1. The sum of these is 19, which is the alarm number.

Return to normal operation by pressing the right-hand button.

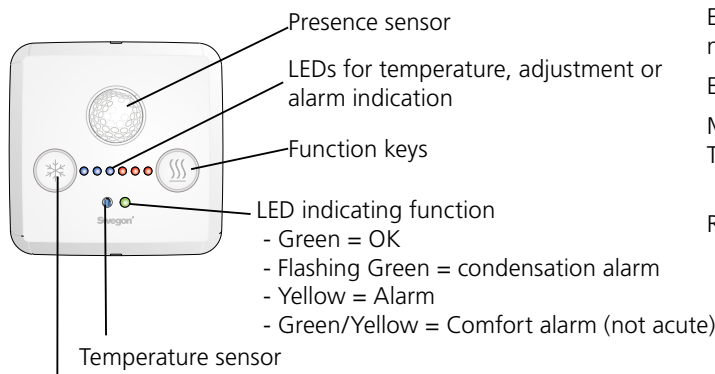

Function keys

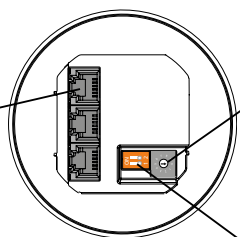

3 parallel RJ12 ports (Modbus) for connections e.g. controller, additional sensor module or PC with the help of Cable converter USB-RJ12

Addressing the sensor module. 10 sensor modules can be connected to each master unit, each one must have a unique address to work.

Switch for termination resistance. On the last sensor module in the circuit switch 1 is set to On.

# Installation, design cover

A8, B7

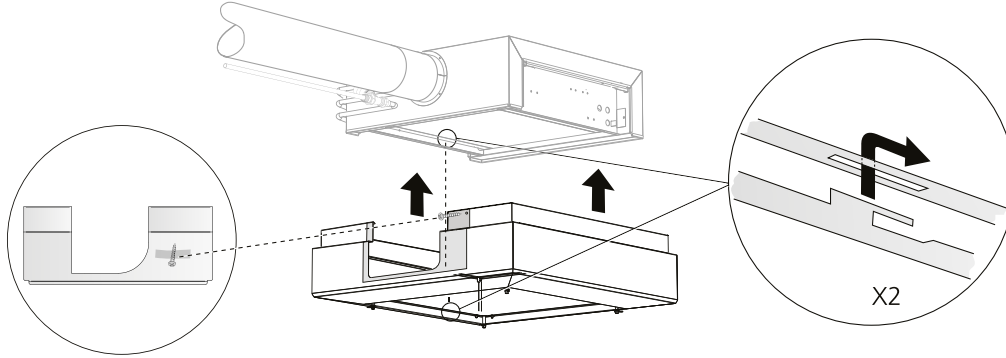

A9, B8

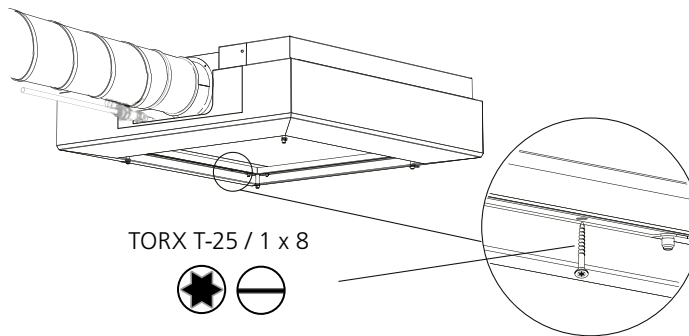

A10, B9

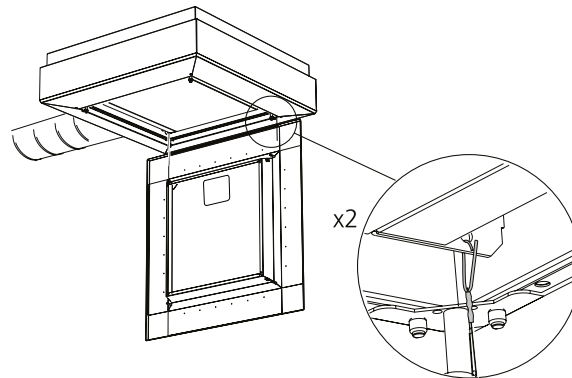

A11, B10

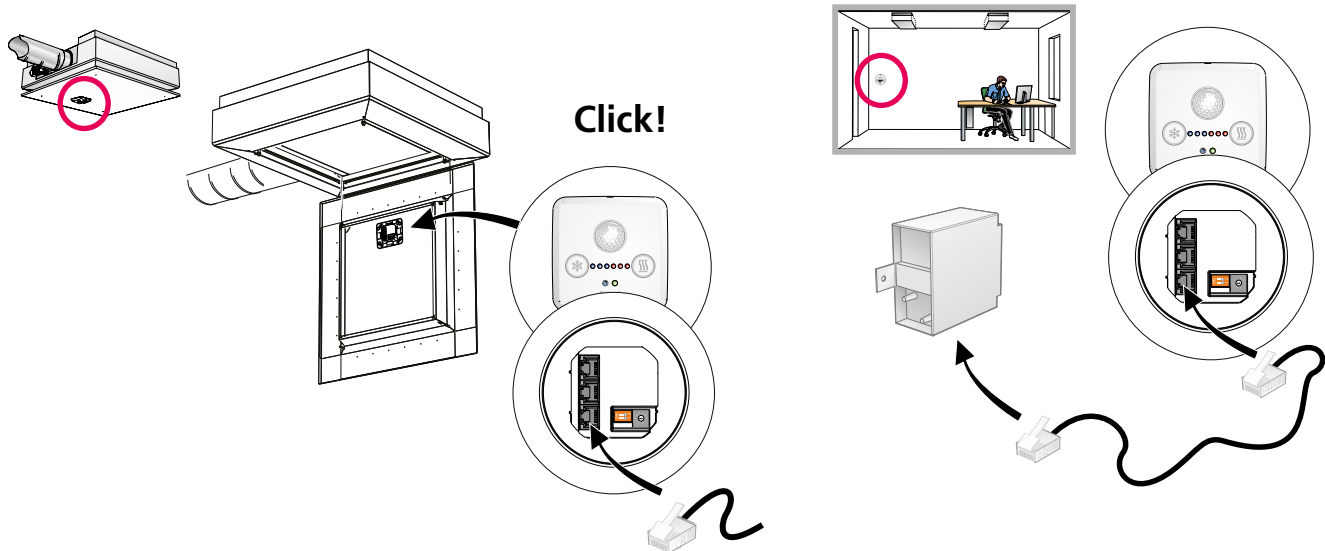



A12, B11

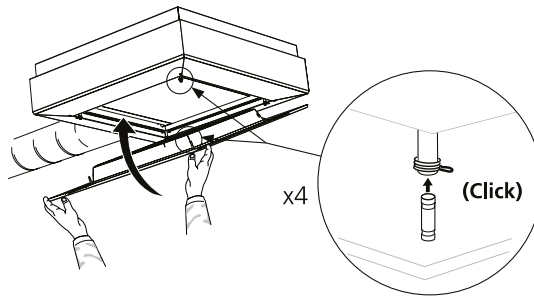

A13, B12

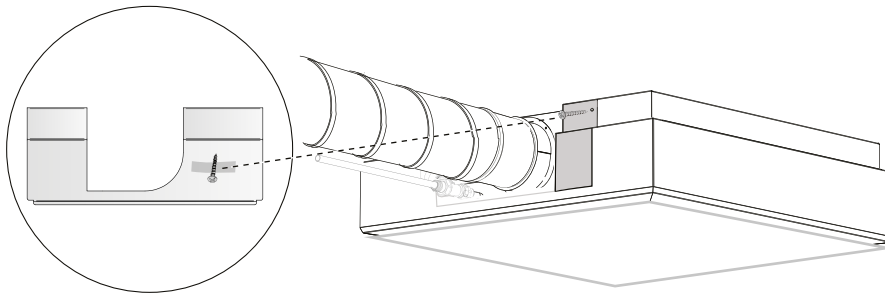

A14

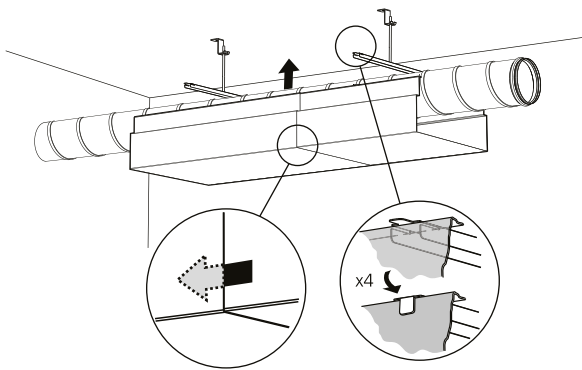

B13

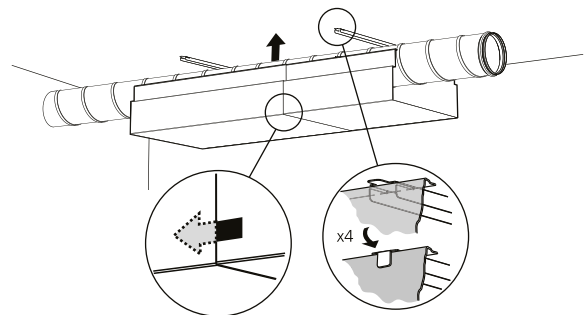

A15, B14

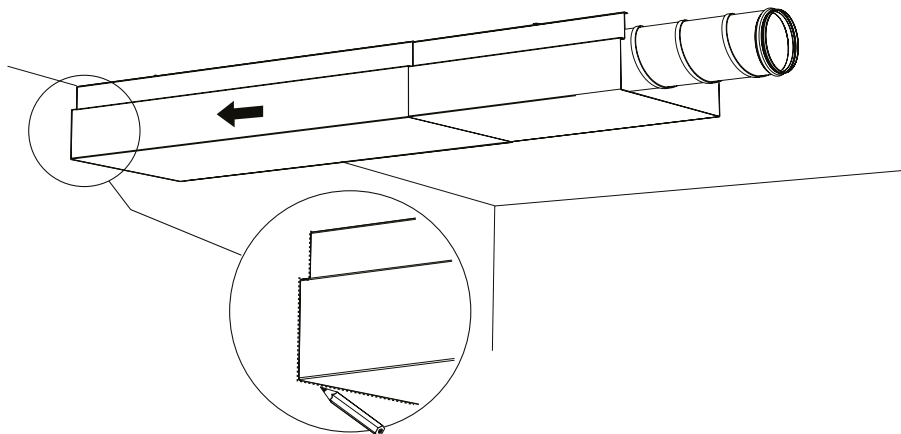



A16, B15

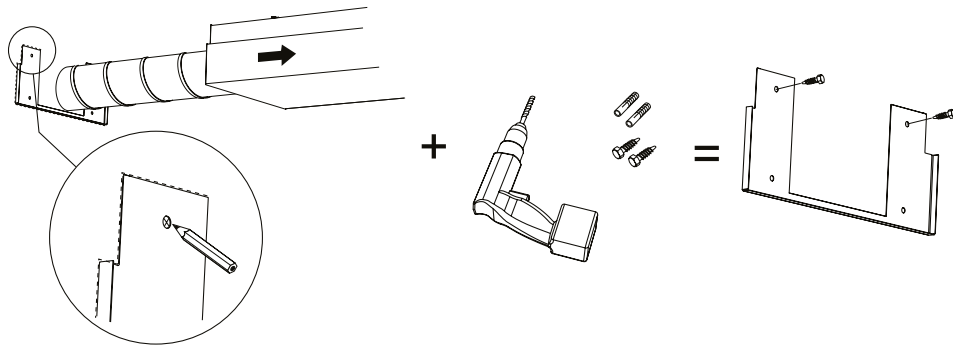

A17, B16

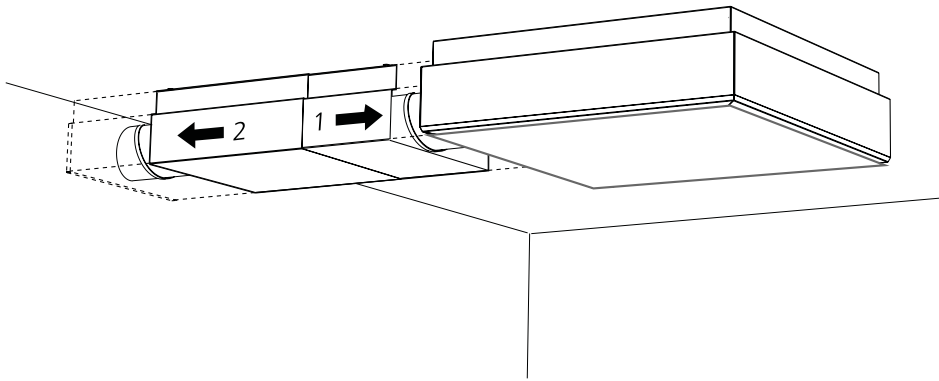

# Maintenance

