

SIRI

Measurement and control damper



QUICK FACTS

- Type-approved method of measurement
- Short installation length
- Can be cleaned
- Low flow-generated noise level
- High measurement accuracy
- Ductwork leakage class C, EN 1751

Technical Description

Design

The control function itself is built into a surface-mounted collar and offers uniform and centric throttling when the damper blades are actuated towards the centre. The result will be a laminar and uniform air stream pattern with a low noise level. Thanks to its compact design, the SIRI is simple to integrate into the ductwork. Casing leakage is according to ductwork leakage class C (EN 1751).



Figure 1. Installation.

Materials and finish

The damper structure and the control discs are made of galvanized sheet steel, and the other components are made of plastic. The connection spigots are fitted with rubber seal rings.

Function

The SIRI is designed for regulating the airflow in circular ventilation ducts. The control disks form an almost ideal measurement flange that enables simple and reliable airflow measurement. SIRI is ideally suited for installation in ducts that require regular cleaning, because it can be opened completely (up to and including size 630 mm).

Installation

The SIRI damper should be installed at a suitable distance from obstruction sources. The SIRI damper must not be strained by the weight from connecting ducts. This is especially the case if it is connected to a vertical run of ducts. In undisturbed measurement an accuracy of $\pm 5\%$ is achieved. With installation options according to figure 2, an accuracy of $\pm 10\%$ is achieved.

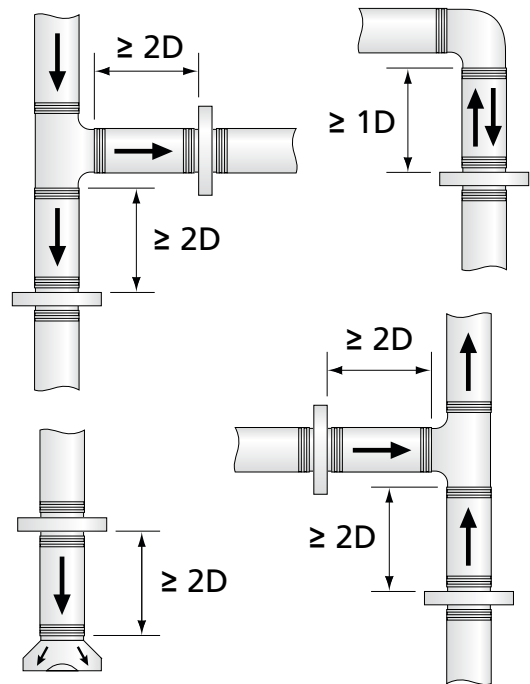

Figure 2. Planning.

Commissioning

Maximum measurement deviation is $\pm 10\%$, even when the damper is positioned near a T-piece, transition piece or duct bend. See figure 2, regarding straight duct length demands. The pressure differential can be read and the airflow can be determined from K-factors (COP) or commissioning diagrams by using the fixed measuring points.

A label containing k-factor table and commissioning diagrams is attached to one of the measuring points at delivery. When commissioning, set desired throttling using a screwdriver or ring spanner. See table Ring spanner sizes.

Maintenance

The damper is maintenance-free. Whenever needed, clean the damper by vacuum-cleaning with a brush nozzle.

When cleaning a duct, first note what position the damper is set to before opening fully. Restore the setting of the damper after cleaning.

Environment

Declaration of Construction Materials is available from www.swegon.com.

Ring spanner sizes

SIRI – Size	Ring spanner size
80-160	8 mm
250-315	10 mm
400-630	15 mm
800	22 mm

Sizing

Sound Power Level

The diagrams for the various sizes show the total generated sound power (L_{Wtot} dB), as a function of the airflow and pressure drop across the damper. By correcting L_{Wtot} with the correction factors from Table K_{ok} , the sound power level for each octave band ($L_W = L_{Wtot} + K_{ok}$) can be obtained.

Sound data – SIRI

Table K_{ok}

Size	Mid-frequency (Octave band) Hz							
	63	125	250	500	1000	2000	4000	8000
80	-4	-5	-6	-14	-21	-27	-31	-33
100	-4	-4	-6	-14	-21	-27	-31	-33
125	-4	-4	-7	-15	-22	-27	-32	-35
160	-4	-4	-9	-16	-23	-27	-34	-36
200	-3	-5	-10	-17	-23	-28	-35	-36
250	-2	-5	-11	-17	-22	-28	-35	-35
315	-2	-6	-13	-18	-22	-28	-34	-35
400	-2	-7	-13	-19	-21	-27	-33	-34
500	-2	-7	-13	-18	-22	-27	-31	-33
630	-1	-7	-12	-16	-22	-26	-29	-32
800	-1	-7	-13	-17	-23	-27	-30	-33
Tol. ±	6	5	3	2	2	2	2	4

Engineering graphs - SIRI

Airflow - Pressure drop - Sound level

- The diagrams are not to be used for commissioning.

SIRI 80

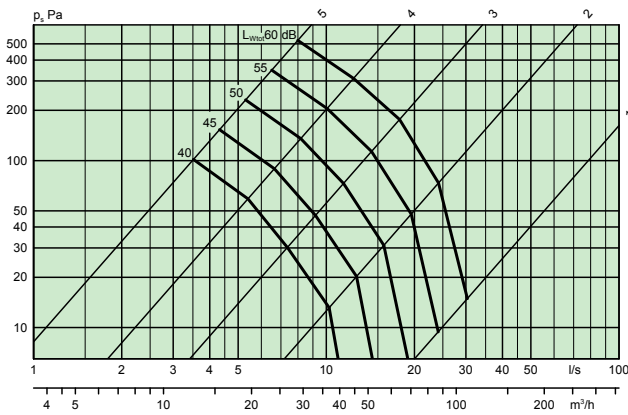

SIRI 100

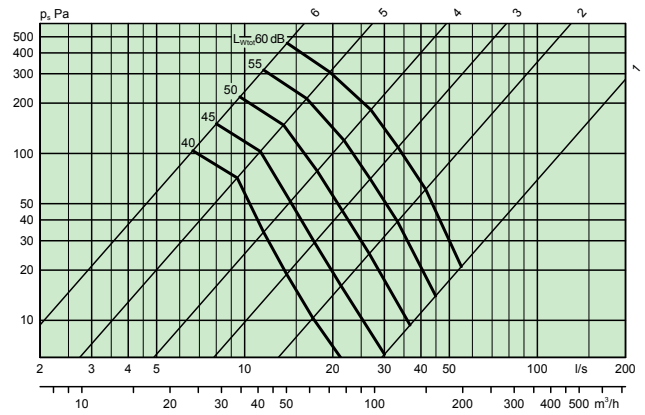

SIRI 125

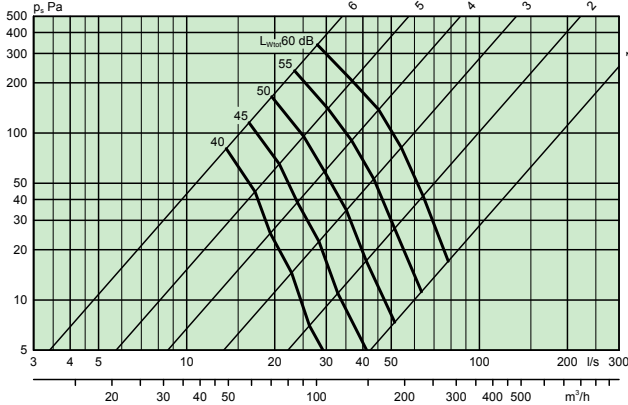

SIRI 160

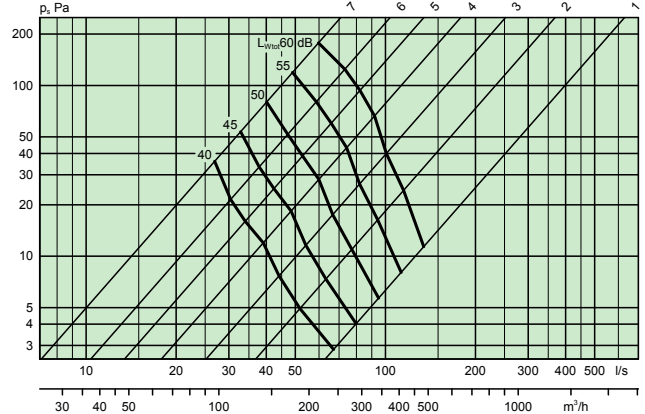

SIRI 200

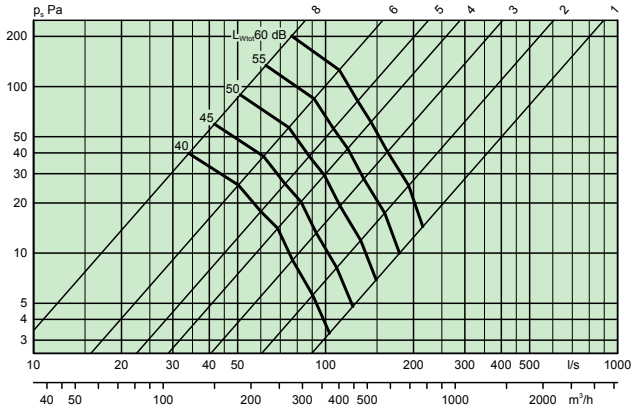

SIRI 250

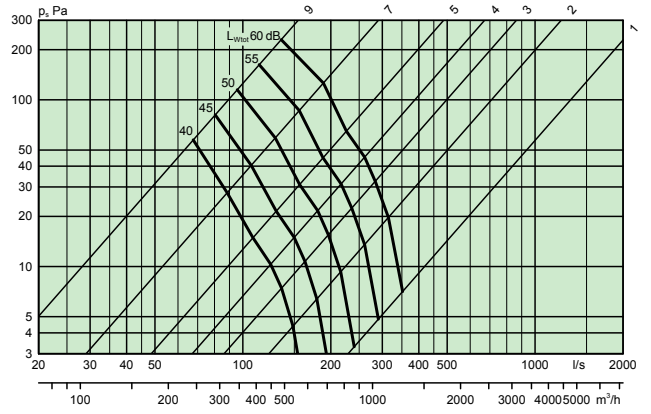

SIRI 315

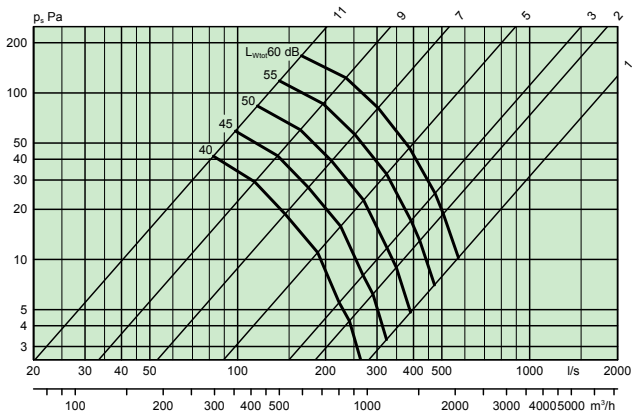

SIRI 400

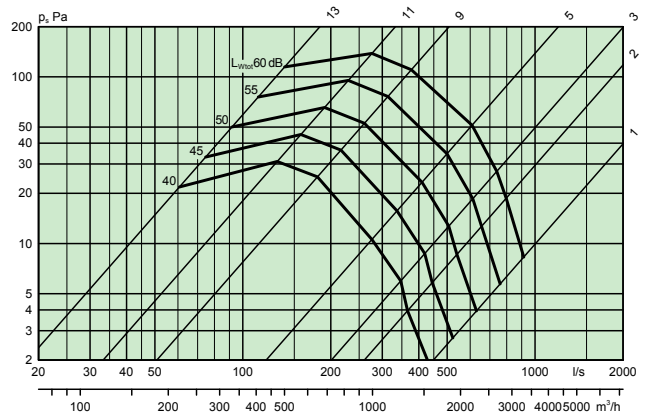

SIRI 500

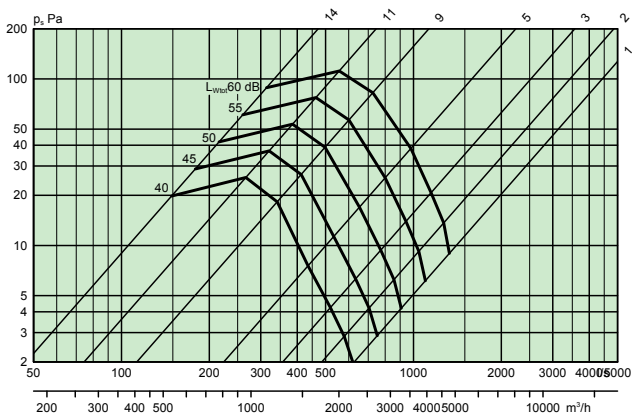

SIRI 630

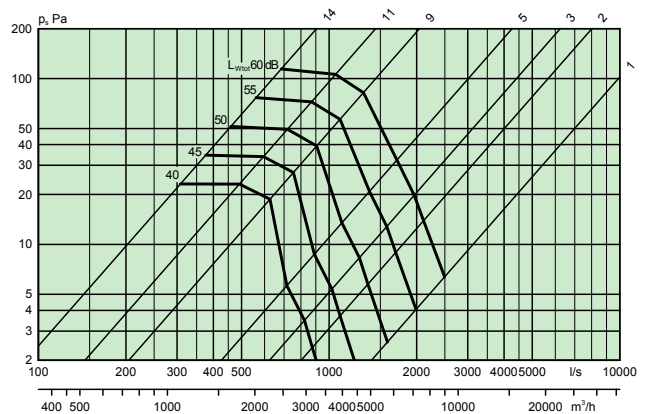

SIRI 800

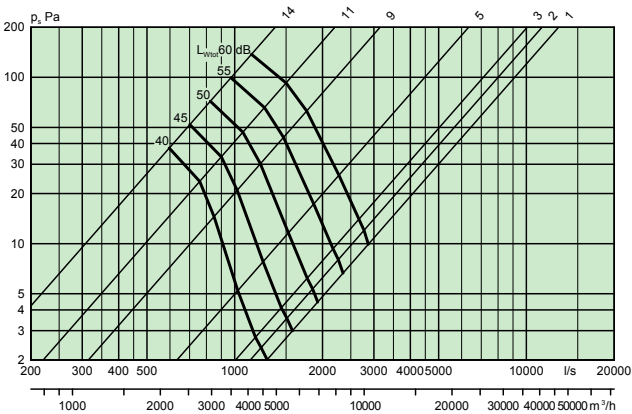

Dimensions and weight

SIRI

Size	Dimensions (mm)					Weight (Kg)
	Ød	ØD	L	A	B	
80	78	145	115	30	35	0,5
100	98	165	120	30	35	0,6
125	123	188	130	40	35	0,8
160	158	230	140	40	35	1,1
200	198	285	140	40	45	1,5
250	248	285	180	55	45	2,2
315	313	410	180	55	50	3,0
400	398	525	220	60	65	5,0
500	498	655	220	60	80	8,5
630	628	815	220	65	95	12,1
800	798	1020	280	85	107	24,5

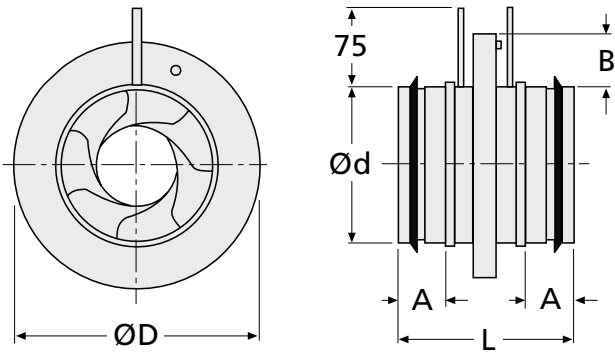

Figure 3. SIRI

Ordering key

Product

Commissioning damper SIRI a -aaa

Version:

Size:
80, 100, 125, 160, 200, 250, 315, 400, 500, 630, 800

Specification text

Swegon's type SIRI circular measurement and commissioning damper with the following functions:

- Type-approved method of measurement
- Fixed measurement tapings
- Lockable damper knob with damper blade position indicator
- Non-fouling design

Size SIRI a -aaa xx items