

# SWAN WTW

Installation - Commissioning - Maintenance

---

---

## **Supply air sections**

SWAN ACT: Active air diffuser section with 2-4 slots and 1158 mm long for installation in a SWAN T commissioning box.

SWAN PASS: Passive air diffuser section with 2-4 slots and 1158 mm long (looks like the active section) with cover plate for installation between the active slot diffusers.

SWAN END: Passive end diffuser section with 2-4 slots and varying length 595-1174 mm (looks like the active section) with cover plate for installation as the start and end diffuser including the end-piece, 16mm).

## **Accessories**

### **Commissioning box:**

SWAN T: Made of galvanised sheet steel. The commissioning box contains a commissioning damper and fixed measurement tapping. The same commissioning box as standard in one-off deliveries. The box is supplied with a connection in the long side (L).

### **Sound absorber:**

An accessory for the commissioning box, consisting of sound absorbing material with a reinforced surface layer. Fire resistance rated to B-s1,d0 in accordance with EN ISO 11925-2.

### Installation

The commissioning box should be suspended by means of threaded rods from the ceiling which are secured with screws in blind rivets in the top of the commissioning box, or by means of the mounting brackets on the sides of the commissioning box for attachment to mounting strips or wires. See Figure 3.

Cut an appropriate opening for air diffusers according to the dimension table. Secure the active slot diffusers with screws to the commissioning box by means of the fixed mounting brackets in the diffuser face and the commissioning box respectively. Install the passive diffuser sections and end diffuser sections by screwing a threaded rod (hanger) into the blind rivet of the cover plate. As an alternative, wire or mounting strips can be secured with screws directly into the cover plate. For wall-to-wall installation, jointing pieces are included in the supply for aligning the diffuser sections in a straight line. The jointing pieces are mounted in one end of each diffuser section. Installation: See Figure 6c, step 7.

### Commissioning

Prior to commissioning, you can change the direction of air discharge from the diffuser slots, see Figures 4 and 5. The diffuser face must be mounted in the commissioning box before you begin commissioning the system. Pull the measuring tubes and damper-adjustment cords out of the air diffuser through the slots, blue measuring tube for supply air and transparent tube for extract air, see Figure 2. When you have finished measuring the air pressure and have determined the appropriate damper position, stretch both damper-adjustment cords and tie them together in a so-called commissioning knot.

K-factors are specified in the relevant commissioning instructions at [www.swegon.com](http://www.swegon.com).

### Maintenance

Clean the air diffuser if needed with lukewarm water and dishwashing detergent added. Or use a vacuum cleaner with a brush nozzle for cleaning. The duct system can be accessed after removing the diffuser face and the damper assembly, see Figure 2.

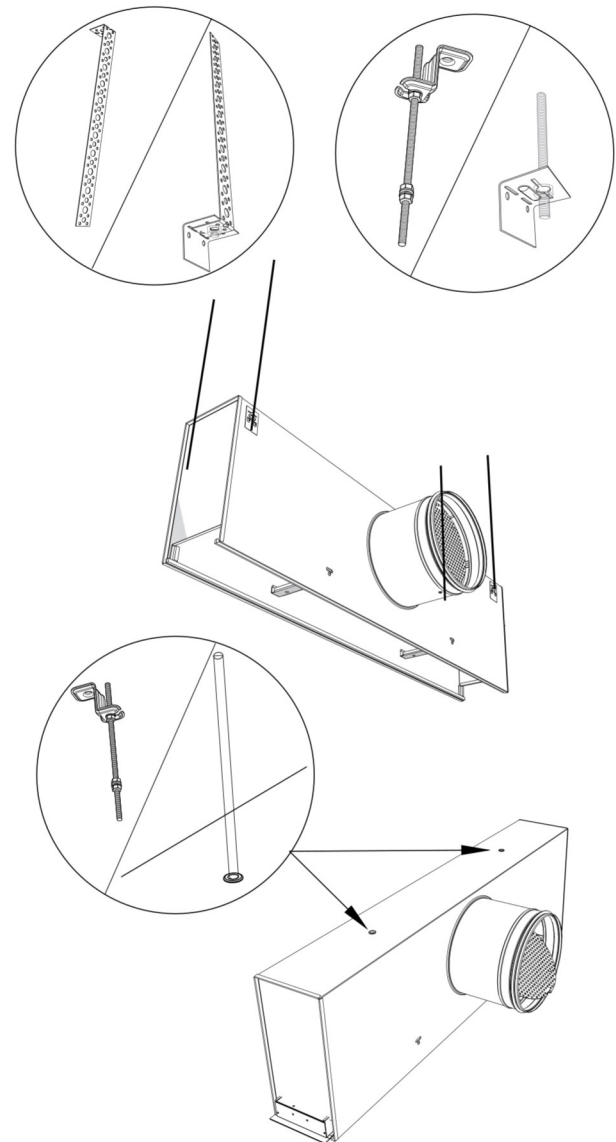

Figure 3. Alternative installation with threaded rod, mounting strips or wire.

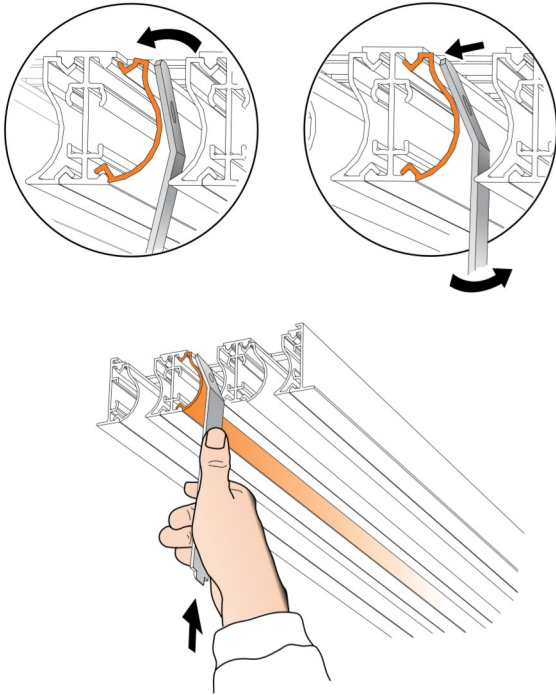

Figure 4a. Installing of the air deflectors.

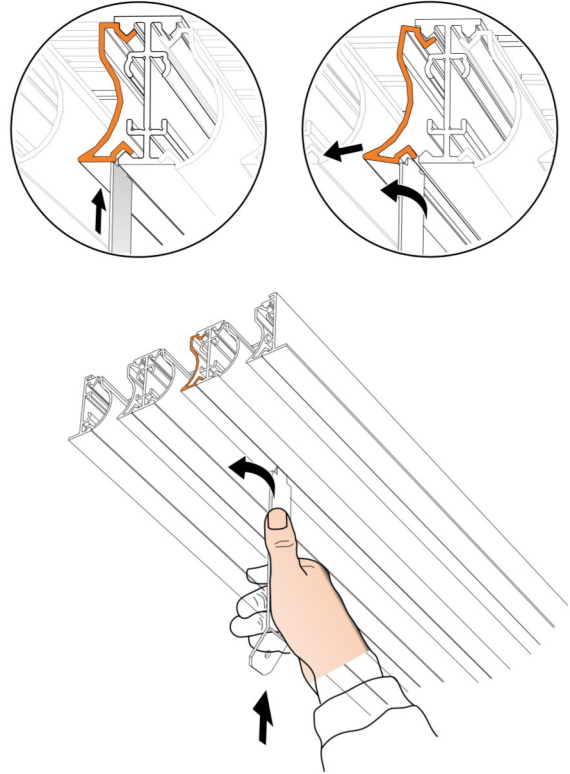

Figure 4b. Dismantle of the air deflectors.

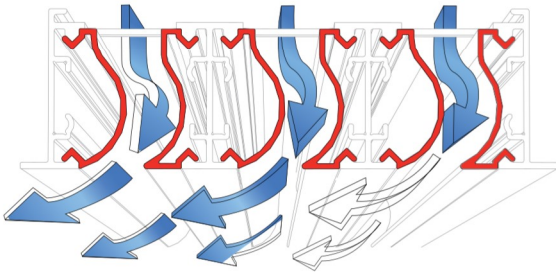

Figure 5a. 1-way air discharge.

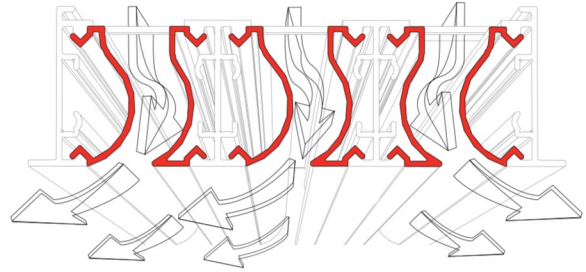

Figure 5b. 2-way air discharge.

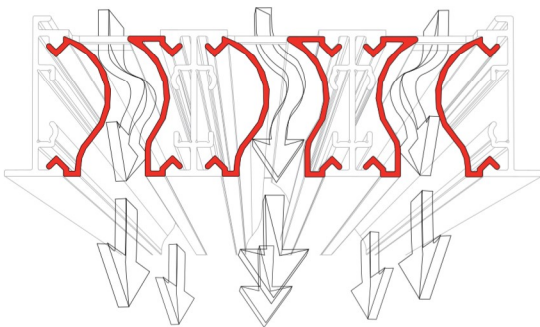

Figure 5c. Vertical air discharge.

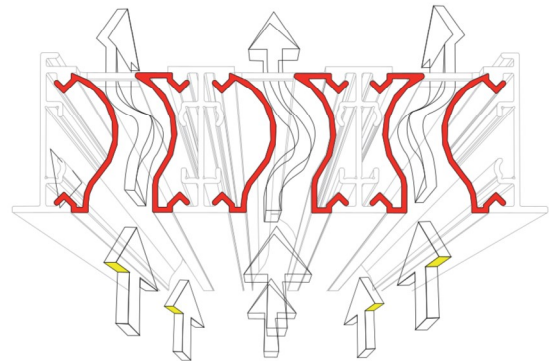

Figure 5d. Extract air.

**Installation example:**

According to Figures 6a-6d

1. Measure the location of the commissioning boxes and the slot diffusers.
2. Start by mounting the commissioning boxes (the products are supplied without mounting accessories).
3. Then install the first slot diffuser, which is a SWAN END. (end- piece in the left end and jointing piece in the right end)

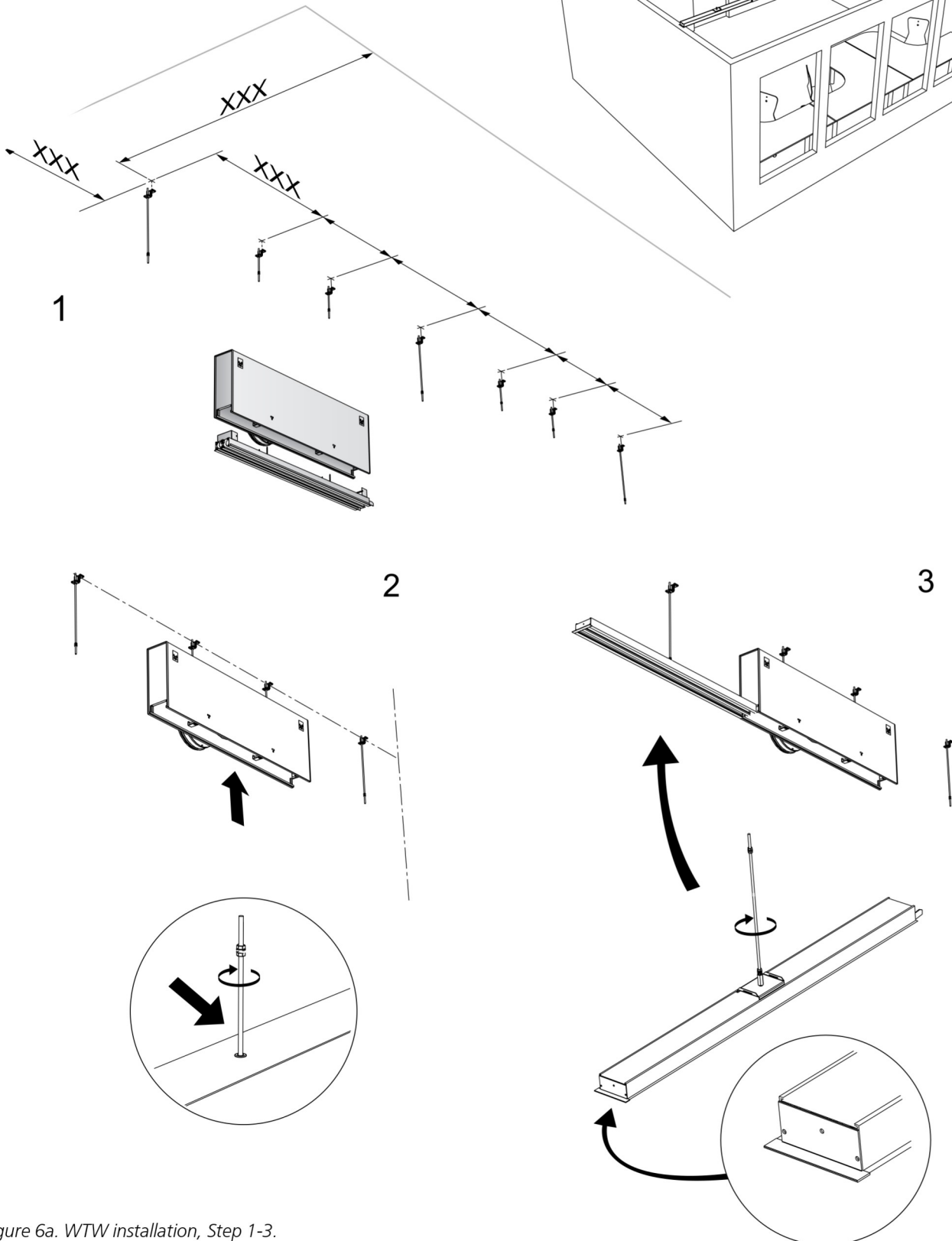
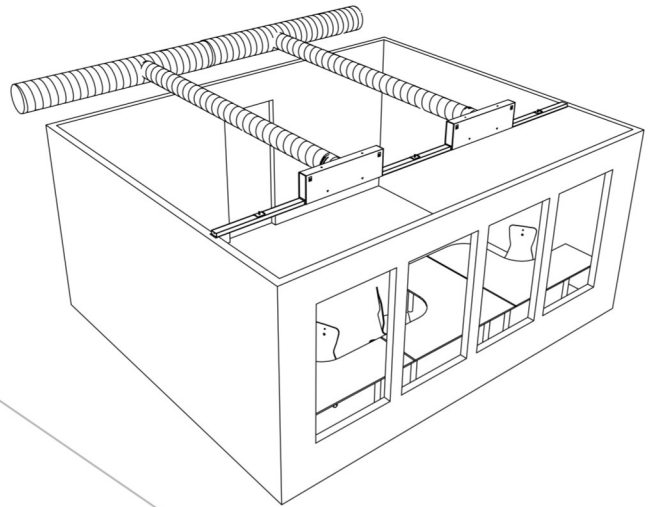

Figure 6a. WTW installation, Step 1-3.

- 4 & 5. Remove the outer air deflectors from the next diffuser (which is an active slot diffuser) to enable you to access and tighten the locking screw against the jointing pieces.
6. Install the SWAN ACT active slot diffuser against the SWAN END's jointing piece and secure the diffuser against the commissioning box with screws.

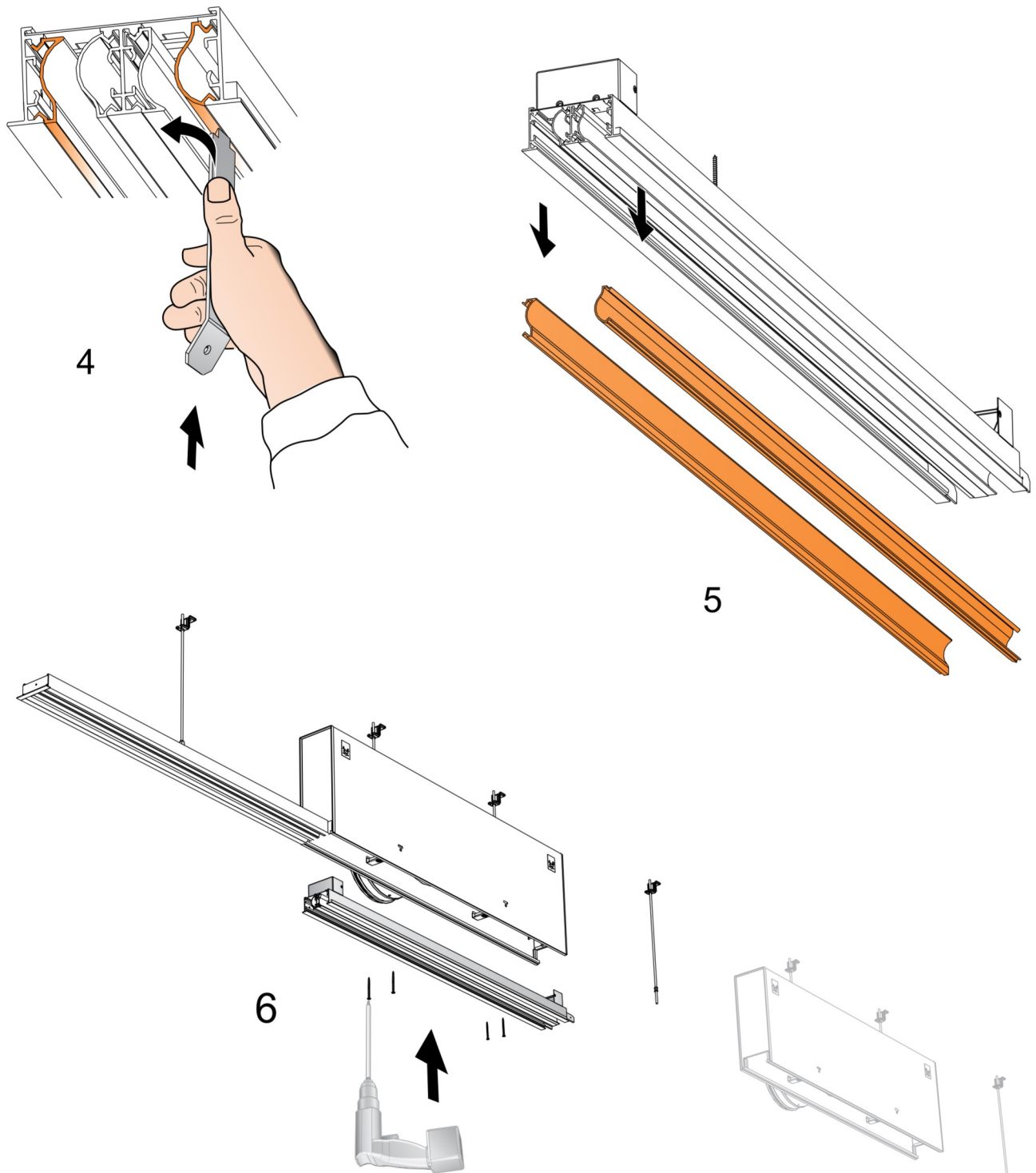

Figure 6b. WTW installation, Step 4-6.

7. Adjust the slot diffuser ends against each other in order to obtain a good joint between the diffusers and lock the jointing pieces with a hexagon spanner (size: 2 mm).
8. Refit the air deflectors into the SWAN ACT slot diffuser and remove the outer air deflectors on the next slot diffuser, in this case: a SWAN PASS which will be located between two commissioning boxes.

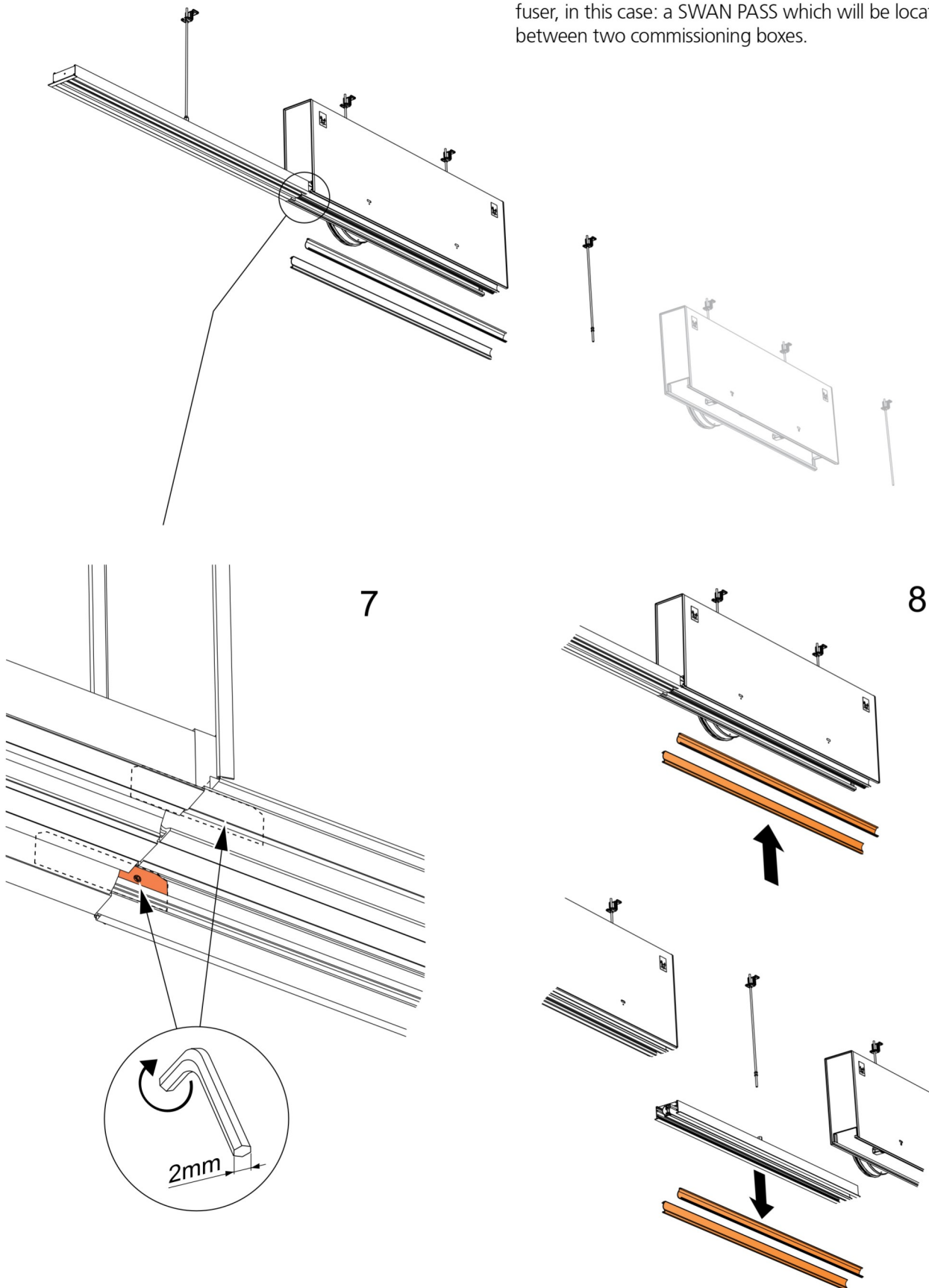

Figure 6c. WTW installation, Step 7 and 8.

9 & 10. Install the SWAN PASS slot diffuser against the preceding slot diffuser and lock the jointing pieces as shown in Item 7.

11. Refit the air deflectors in the SWAN PASS slot diffuser.

Then continue the installation with the next active slot diffuser, in the same way as in Steps 4-8. The last slot diffuser is a SWAN END which in this case should be installed against the other active slot diffuser. It might be necessary to remove the jointing pieces from this last SWAN END slot diffuser.

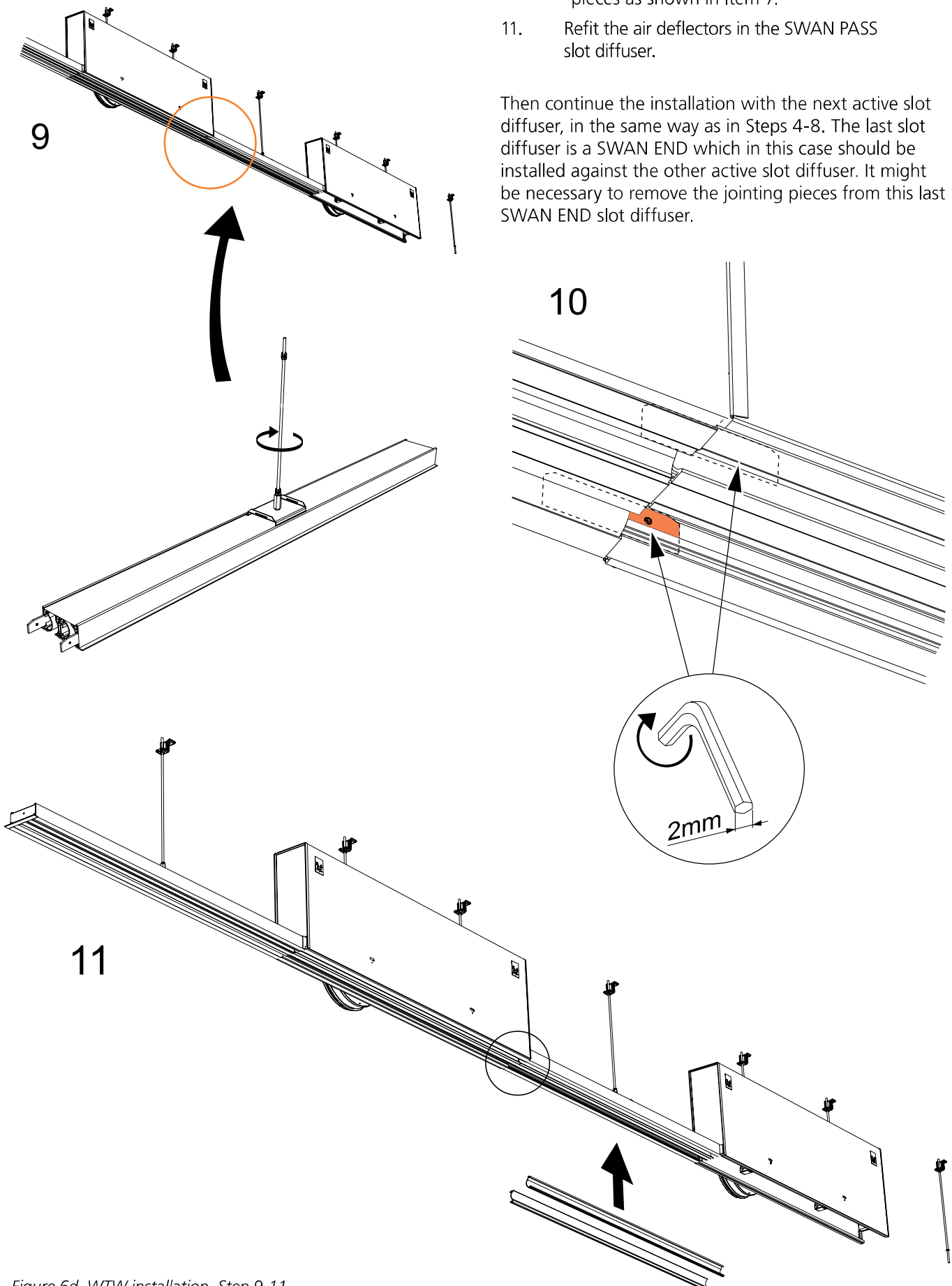

Figure 6d. WTW installation, Step 9-11.

## Dimensions and weights

### SWAN WTW – Dimensions (mm)

Size	A	A1	B	B1	ØD	H-(H+25)	J	K	L
2-1158-160	1158	200	107	92	159	265-290	124	1151	146
2-1158-200	1158	200	107	92	199	304-329	124	1151	166
2-1158-250	1158	200	107	92	249	354-379	124	1151	194
3-1158-160	1158	245	153	137	159	265-290	170	1151	146
3-1158-200	1158	245	153	137	199	304-329	170	1151	166
3-1158-250	1158	245	153	137	249	354-379	170	1151	194
4-1158-160	1158	290	198	182	159	265-290	215	1151	146
4-1158-200	1158	290	198	182	199	304-329	215	1151	166
4-1158-250	1158	290	198	182	249	354-379	215	1151	194

Holemaking size: length = X -32 mm. Width = B -12 mm.

### SWAN T – Position of the duct connection (mm)

SWAN T	P	R	S
Ø160	102	22	163
Ø200	122	22	182
Ø250	147	22	207

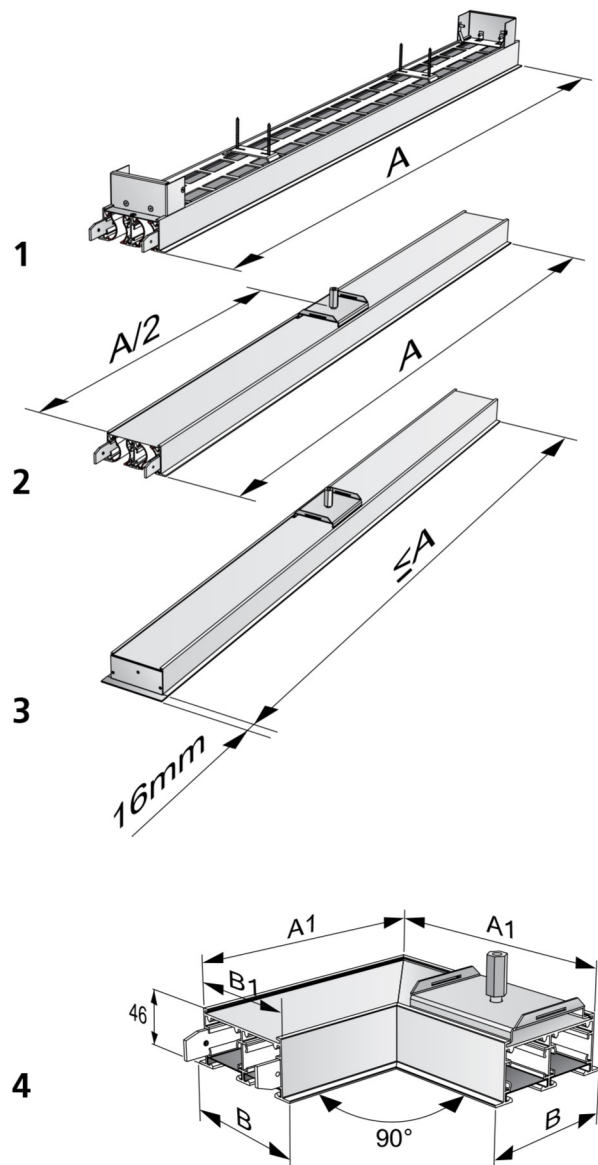
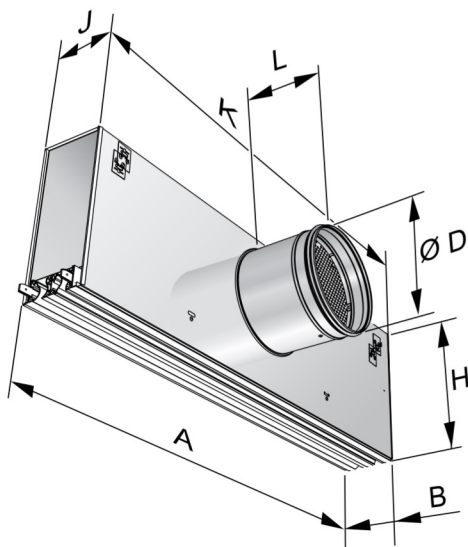
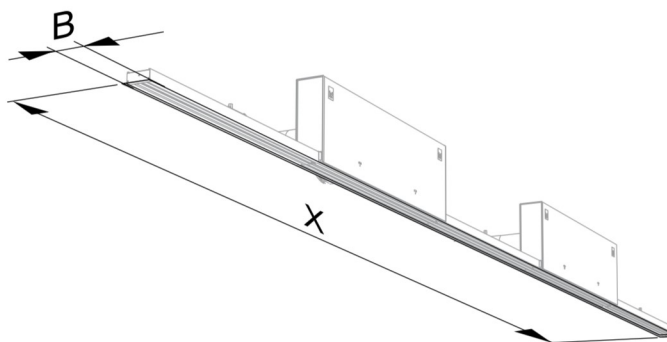

Figure 8. SWAN WTW, parts included:

- 1) SWAN ACT
- 2) SWAN PASS
- 3) SWAN END
- 4) SWAN CORN90 (accessory)



**SWAN WTW – Weight, parts included (kg)**

Size	SWAN ACT	SWAN PASS	SWAN END <sup>*)</sup>	SWAN T
2-1158-160	2,6	2,8	1,4 - 2,8	4.2
2-1158-200	2,6	2,8	1,4 - 2,8	4.9
2-1158-250	2,6	2,8	1,4 - 2,8	5.9
3-1158-160	3,6	4,0	2,0 - 4,0	5.2
3-1158-200	3,6	4,0	2,0 - 4,0	5.8
3-1158-250	3,6	4,0	2,0 - 4,0	6.7
4-1158-160	4,6	5,3	2,7 - 5,3	6.0
4-1158-200	4,6	5,3	2,7 - 5,3	6.7
4-1158-250	4,6	5,3	2,7 - 5,3	7.7

<sup>\*)</sup>SWAN END, min. weight for A=579 and max. weight for A=1158

**K-factor (COP)**

Size	1-way	2-way	Vertical	Extract Air
2-1158 + SWAN Ta 2-160	21	21	18,8	13
2-1158 + SWAN Ta 2-200	22,4	22,4	19,8	16,6
2-1158 + SWAN Ta 2-250	23,4	23,4	19,8	18,7
3-1158 + SWAN Ta 3-160	27,1	–	24,9	15,8
3-1158 + SWAN Ta 3-200	29,4	–	25,8	19,3
3-1158 + SWAN Ta 3-250	32,2	–	25,8	22,8
4-1158 + SWAN Ta 4-160	27,6	27,6	25,1	16,7
4-1158 + SWAN Ta 4-200	35,4	35,4	30,8	22,5
4-1158 + SWAN Ta 4-250	39	39	34,2	29,1

Supply air: 1 measuring tube (blue).  
Extract air: 1 measuring tube (transparent).

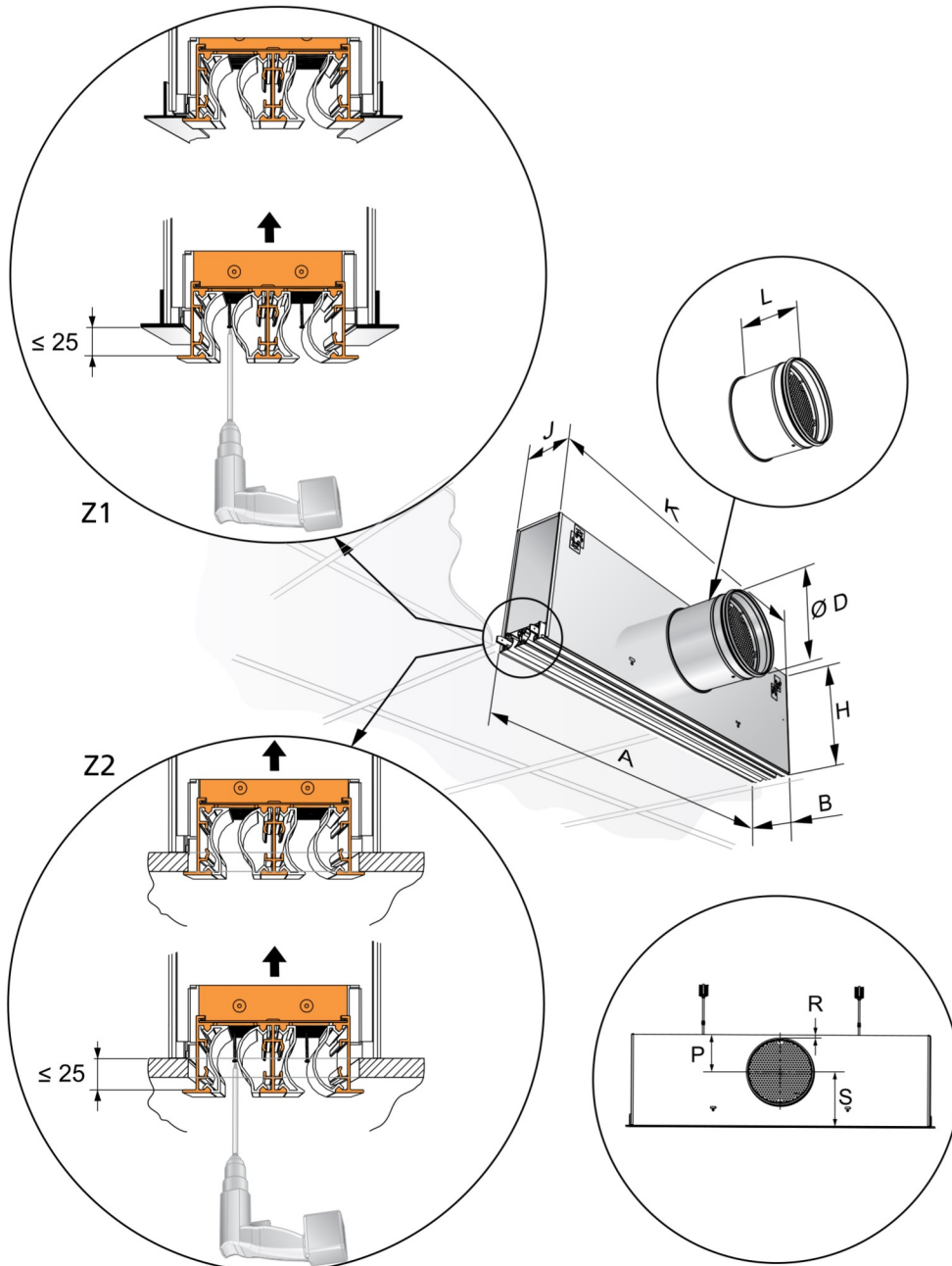

Figure 9. SWAN WTW with SWAN T commissioning box. Z1 = False ceilings, Z2 = Plasterboard ceilings.