

CAURUS

Concealed air supply with building mass connection



QUICK FACTS

- Thermal comfort according to EN ISO 7730
- Very high heating and cooling capacity: heating up to 117 w/m^2 (15 K), cooling up to 126 w/m^2 (8 K)
- Active concrete management
- Superior sound absorption values: α_w up to 0,95
- Integrated telephony noise reduction
- Low construction height
- Functions
 - Cooling
 - Heating
 - Mass connection
 - Acoustics
 - Supply and exhaust air
 - Integral components

Technical description

General

Thanks to its comprehensive functionality, the radiant metal ceiling sail + Caurus with nozzle channel creates an optimal room climate in any environment. It has very high cooling and heating capacities, a comfortable air supply and superior acoustic properties. According to the principle of the thermoactive component system, it also includes the storage mass for the dissipation of heat loads in the overall room thermal concept. This reduces energy requirements and operating costs.

Activation

Water system: The radiant ceiling is a passive system that in the case of cooling absorbs heat from the room via the ceiling surface, transfers it to the water, which is conducted in activation registers, and dissipates it, respectively emits heat in the case of heating.

Two variants of activation registers are available for activating the radiant metal ceiling system:

Activation register A11

- Copper pipe meanders welded to aluminum heat-conducting rails.
- Connected to the ceiling panel using adhesive technology.

Activation register Spectra M

- Copper pipe meanders pressed into aluminum heat-conducting profile with magnetic tape.
- Connected to the ceiling panel using magnet technology. Advantages: The registers can be supplied, fixed and hydraulically connected independently of the ceiling panels. These can be assembled at the end of the installation work. This reduces construction time and the risk of contamination.

Optional performance plus: Convector Wings

When using the activation register A11, a further increase in performance can be achieved by using the Convector Wings developed by Barcol-Air.

Convector Wings are matt black anodized aluminum profiles with slotted «wings» on both sides. With the profile that opens downwards, the Convector Wings can be attached to the straight sections of a pipe meander. This multiplies the heat exchange surface of the radiant ceiling sail, which leads to an increase in water capacity.

Functions

The radiant metal ceiling sail + Caurus is multifunctional. In addition to the thermal functions of cooling/heating and the active concrete management, there is the possibility of further integration: acoustically effective inserts or baffles (Archisonic®), various built-in components (e.g. smoke detectors, lighting).

Combination

- Radiant Metal Ceiling System A11 + Archisonic®

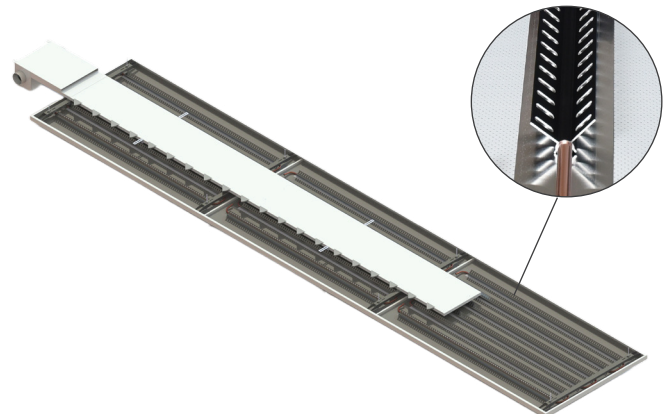
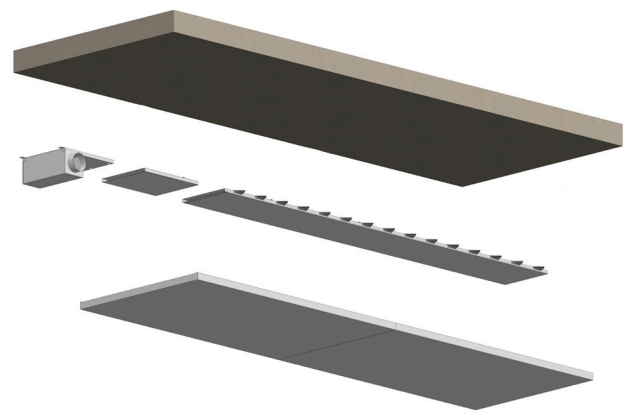

Optional performance plus: Convector Wings

Functional description nozzle channel

With supply air quantities of up to $35 \text{ m}^3/\text{h}\cdot\text{lm}$ per sail, the supply air is introduced horizontally into the room on one side of the sail above the ceiling panels. The warm room air is drawn in by specially developed high-performance induction nozzles on the opposite side of the sail, accelerated above the supply air channel and thereby achieved a high energy transfer into the concrete. The temporarily stored energy can be dissipated at night – if possible with free cooling. Due to the high ventilation efficiency in the room, a draft-free and complete room mixing with a homogeneous temperature profile is created within a very short time.

Operation

Day

The hygienically necessary air volume flow emerges from the high-performance induction nozzles. This induces warm room air from behind the sail. Part of the energy is dissipated directly, another heats the concrete. The room temperature always remains comfortable.

Night

At night, no supply air is required in the building. The water can be cooled by free cooling (without the use of the refrigerator). Through the exchange of radiation between warm concrete and cold heat conducting rails, the energy is extracted from the concrete and prepared for the absorption of excess energy the next day.

Supply air volume flow

Maximum supply air volume flow per linear meter of nozzle channel at under temperature:

6 K	$35 \text{ m}^3/\text{h}$
8 K	$33 \text{ m}^3/\text{h}$
10 K	$30 \text{ m}^3/\text{h}$

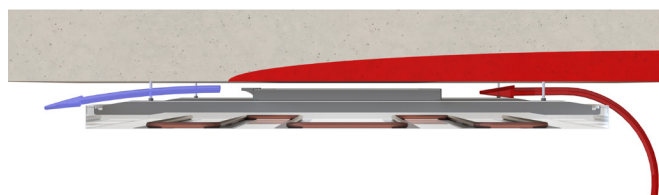
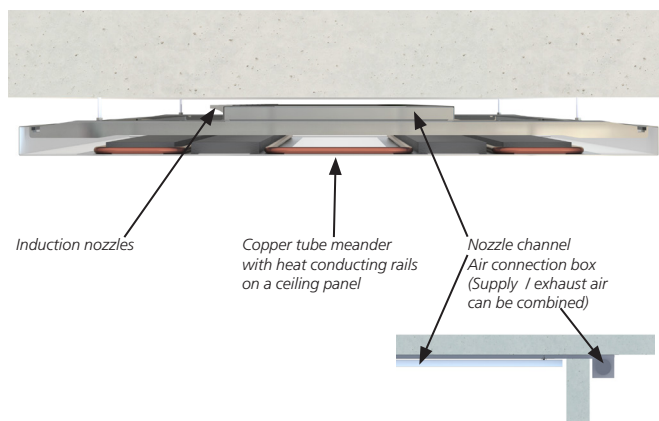

Technical data

Capacity

Water

Initial data is presented below.

Material ceiling panel	Aluminium	Steel
Perforation	Rg 1,5 – 11 %	Rg 1,5 – 11 %
Activation (Distance heat conducting rails hcr: 100 mm)	A11-----②	A11 + Convector Wings.....① A11——③ Spectra M- - -④
Activation method	on fleece	on fleece

(Capacity specifications without object-specific performance-increasing factors. Depending on the configuration, an additional output of 20 w/m² of panel area is achieved through concrete management.)

EN 14240:2004

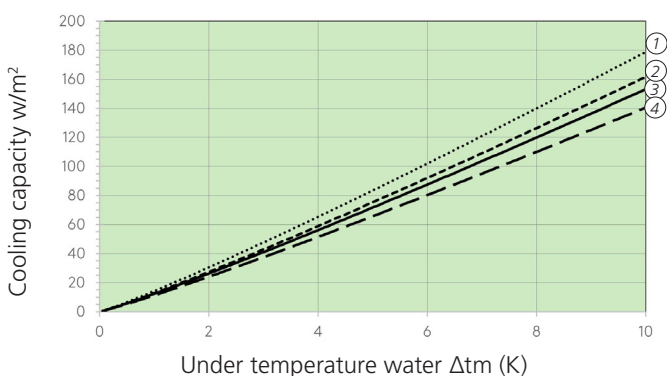

EN 14037:2016

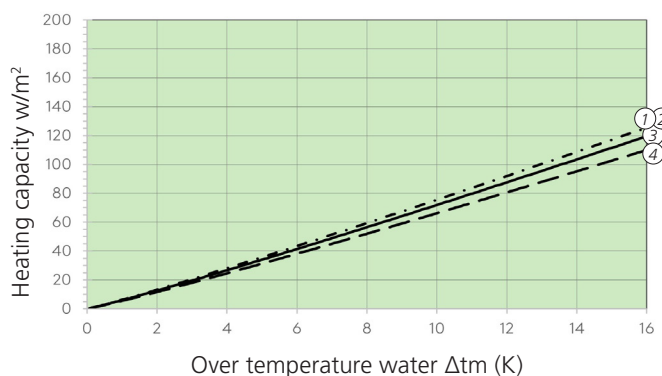

Activation	Version	Cooling 8 K	Cooling 10 K	Heating 15 K ⁽¹⁾
A11	① Steel + Convector Wings	up to 140 w/m ²	up to 179 w/m ²	up to 117 w/m ² (-.-.-)
A11	② Aluminium	up to 126 w/m ²	up to 162 w/m ²	up to 117 w/m ² (-.-.-)
A11	③ Steel	up to 120 w/m ²	up to 153 w/m ²	up to 112 w/m ²
Spectra M	④ Steel	up to 110 w/m ²	up to 140 w/m ²	up to 102 w/m ²

¹⁾ When the supply air is running, there is a 20 to 40 % higher heating capacity.

Notice

- SN EN 14240: The cooling capacity is related to the active area according to SN EN 14240:2004. The active area is calculated according to SN EN 14240 from the number of heat-conducting rails x length of heat conducting rail x distance between heat-conducting rails.
- SN EN 14037: The heating capacity is related to the active area according to SN EN 14037:2016. The active area is calculated according to SN EN 14037 from the length of the ceiling panel x the width of the ceiling panel.

Air

Air volume	2 K	4 K	6 K	8 K	10 K
50 m ³ /h	32 W	64 W	96 W	128 W	160 W
75 m ³ /h	48 W	96 W	145 W	192 W	240 W
100 m ³ /h	64 W	128 W	192 W	256 W	320 W
200 m ³ /h	128 W	256 W	384 W	512 W	640 W

Base: $\rho_L = 1,15 \text{ kg/m}^3 / c_L = 1,006 \text{ KJ/kgK}$

Recommended use for EN ISO 7730, class A / B. Further uses possible according to project-specific evaluation.

Acoustics

Sound absorption (Ceiling panel)

Initial data: Radiant metal ceiling sail perforated, distance hcr 100 mm, installation height 200 mm.

With supply air channel the total sound absorption level decreased α_w by 0,05 [-].

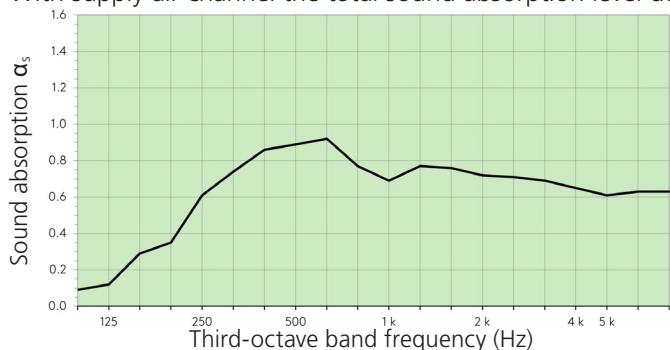

Perforation 1,5 mm – 11 %	with acoustic fleece
Additional inlay	without
Practical sound absorption α_p	250: 0,55 500: 0,90 1k: 0,75 2k: 0,75 4k: 0,65
Sound absorption α_w	α_w : 0,75
Sound absorption class	C (EN ISO 11654)

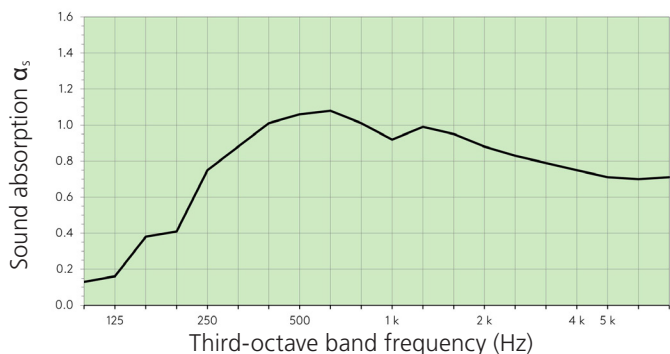

Perforation 1,5 mm – 11 %	with acoustic fleece
Additional inlay	1 strip on the long sides of cp
Practical sound absorption α_p	250: 0,70 500: 1,00 1k: 0,95 2k: 0,90 4k: 0,75
Sound absorption α_w	α_w : 0,90
Sound absorption class	A (EN ISO 11654)

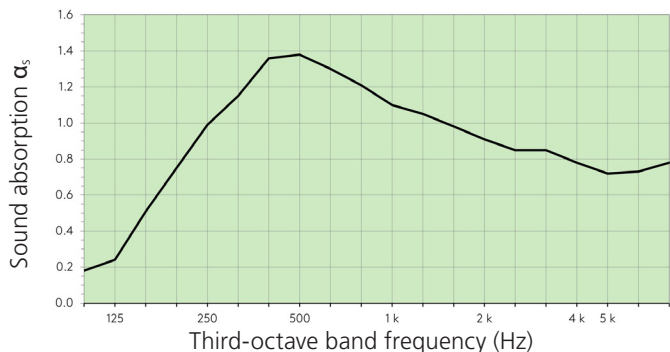

Perforation 1,5 mm – 11 %	with acoustic fleece
Additional inlay	Strips between hcr
Practical sound absorption α_p	250: 0,95 500: 1,00 1k: 1,00 2k: 0,90 4k: 0,80
Sound absorption α_w	α_w : 0,95
Sound absorption class	A (EN ISO 11654)

Air connection box

Standard sound level difference (Telephony sound attenuation)

Versions		
without internal attenuation	$D_{new} = 58 \text{ dB}$	$D_{new} = 50 \text{ dB}$
with internal attenuation	$D_{new} = 62 \text{ dB}$	$D_{new} = 55 \text{ dB}$

Sound power level L_{WA}

Supply air volume	q_v $q_v/lm \text{ channel}$	m^3/h $m^3/lm \cdot h$	76 25	90 30	104 35	118 40	136 45
Sound power level	L_{WA}	dB	24,1	27,3	31,0	34,7	38,2

System

Ceiling system

- Sail
 - Rectangular panels

System components

- Nozzle channel with induction nozzles
- Air connection box for access in the corridor

Installation systems

- Installation high: min. 80 mm
 - Hook-on systems
 - Threaded rods or ropes

Materials, weight and dimensions

Materials and weight

Activation	Material	Weight (incl. activation, water)	Building material class ⁽¹⁾ (EN 13501-1)
A11	Aluminium 1,00 mm	3,8 – 6,5 kg/m ²	A2-s1, d0
A11	Steel 0,70 mm	6,5 – 9,0 kg/m ²	A2-s1, d0
Spectra M	Steel 0,70 mm	10,0 – 13,3 kg/m ²	B-s2, d0

¹⁾ Also depends on the acoustic inserts.

Dimensions

Sail length	Sail width	Sail height
min. 1000 mm	min. 400 mm	min. 80 mm ⁽¹⁾
project specific	max. 1200 mm	max. 200 mm

¹⁾ System structure without tolerance of the concrete ceiling.

Changing nozzles

If you want to be able to easily replace nozzles at a later time (e.g. for blind nozzles), the upper edge of the channel must be away 20 mm from the concrete ceiling. The nozzles can be used from above without screws. Alternatively (if no 20 mm above the channel is possible) they can be inserted into the channel from below (ATTENTION: the direction of the nozzle discharge changes! The nozzles must be screwed!). With nozzles from below it should be noted that the nozzles still blow out OVER the panel edge (loss of capacity).



80 mm installation height ⁽¹⁾
 40 mm perforated metal ceiling panel
 10 mm substructure
 25 mm supply air channel
 5 mm air gap

Surface

Versions

- Powder coating
- Digital printing on request

Colors

- Standard RAL 9010
- Other RAL / NCS colors on request

Perforations

- Standard perforations
- Other perforations on request

Standard perforations:

Rd 1,5 – 11 %

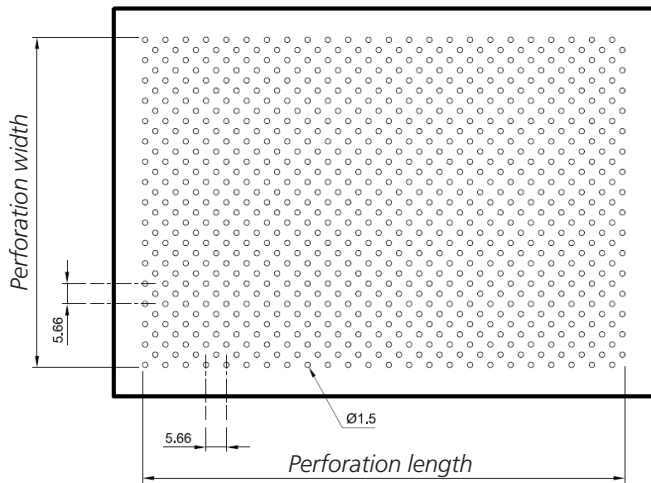

Rg 1,5 – 11 %

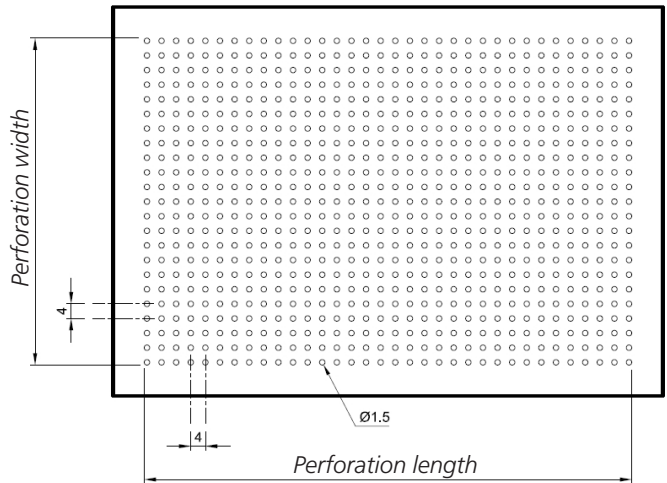

Rd 1,5 – 22 %

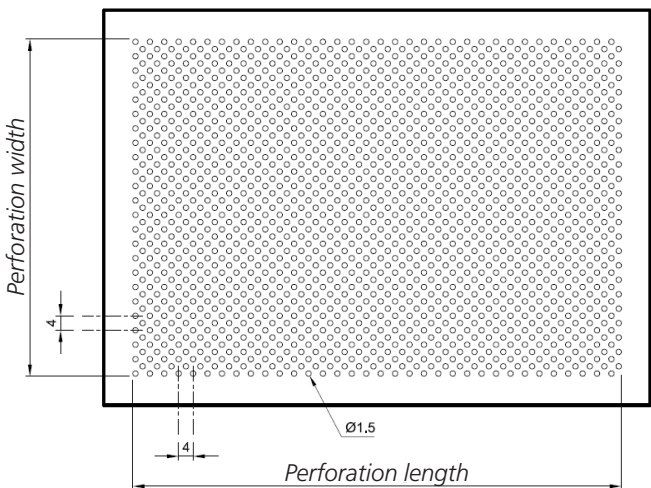

Rg 2,5 – 16 %

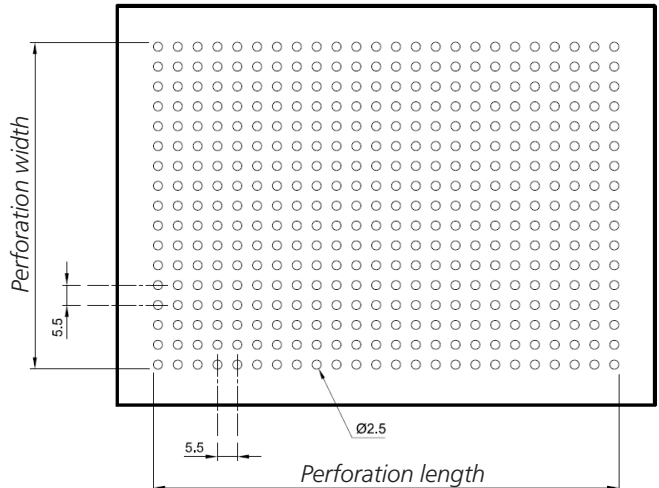

Swegon Klimadecken GmbH

Scharzwaldstrasse 2

64646 Heppenheim

T: +49 6252 7907-0

F: +49 6252 7907-31

klimadecken@swegon.de

swegon.de/klimadecken