

Project: VZT  
 Unit name: AHU4 - Integrovaný DX+Glykolový okruh - Design data

Date: 31/10/2021  
 24 / 1.0.20211027.1204652  
 Unit ID: AD-10001019410

GOLD F CX  
 Manufactured by Swegon, Kvänum, Sweden

Dimensioning data		AHU4 - Integrovaný DX+Glykolový okruh	
Unit size			035
Air density			1.200 kg/m <sup>3</sup>
Supply air flow			5,000 m <sup>3</sup> /h
Static pressure drop	Outdoor air duct		50 Pa
	Supply air duct		350 Pa
Extract air flow			5,000 m <sup>3</sup> /h
Static pressure drop	Extract air duct		350 Pa
	Exhaust air duct		50 Pa
Climate data		Bratislava, Slovakia	
Weather station, reference		BRATISLAVA-STEFANIK, Slovakia	
Design outdoor temperature, summer			32.0 °C
Design outdoor humidity, summer			40 %
Design outdoor temperature, winter			-16.0 °C
Design outdoor humidity, winter			90 %
Supply air temperature, summer			17.0 °C
Supply air temperature, winter			20.0 °C

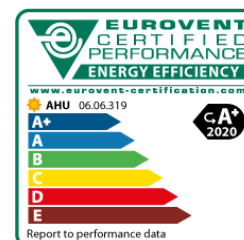

Key Performance Data		
Specific fan power SFPv	Purging flow including leakage, clean filters	1.67 kW/(m <sup>3</sup> /s)
Supply air dry temp. efficiency ratio (+5/+25°C)		70.1 %
Eurovent Energy Efficiency Class	Summer: A+ C, 2020	Winter: B 2016
Eurovent; Fs_Pref:	Summer: 0.84	Winter: 0.83
ErP Commission Regulation (EU) No 1253/2014		Compliant 2018

Project: VZT  
 Unit name: AHU4 - Integrovaný DX+Glykolový okruh - Design data

Date: 31/10/2021  
 24 / 1.0.20211027.1204652  
 Unit ID: AD-10001019410

Casing	
Construction	Frameless, double skinned panels with mineral wool insulation
Panels	56mm thick with 1mm thick steel sheet inside and out. Outer sheet with grey painted finish
Thermal insulation class	T2
Thermal bridging class	TB2
Casing leakage class	L1(M) / L2(R) according to EN 1886:2007 at -400 Pa and +700 Pa
Casing strength	D1(M)
Hygiene	Compliant with the requirements of VDI 6022

Electrical connections	
GOLD F	3-phase, 5-wire, 400 V-10/+15%, 50 Hz, 20 A
Cooling machine, DX	3-phase, 4-wire, 400 V±10%, 50Hz, 25A
Heating coil, electrical, in casing	3*400V+N+PE, 32A

Functional sections viewed in the direction of air flow	Velocity m/s	Air Temperature in/out Winter °C	Air Temperature in/out Summer °C	Power kW	Design Pressure drop Pa	Noise Level dB(A)
<b>Outdoor air duct</b>					-50	66
Damper					-0	
End section					-2	
Cooling machine, DX	0.94		32.0/16.3		-10	
Filter	0.76				-49	
Coil heat exchanger	0.81	-16.0/14.0	16.3/16.3		-52	
Fan				1.23	515	
Heating coil, electrical, in casing		14.7/20.0		8.84	-0	
End section					-2	
<b>Supply air duct</b>					-350	77
<b>Extract air duct</b>					-350	67
End section					-2	
Spacer section					-	
Prefilter					-16	
Filter	0.76				-25	
Coil heat exchanger	0.81	22.0/0.8	26.0/26.0		-52	
Fan				1.21	509	
Cooling machine, DX	0.97		26.7/52.3		-12	
End section					-2	
Damper					-0	
<b>Exhaust air duct</b>					-50	79

Sound power to duct, measured according to ISO 5136  
 Noise reduction for function section included to duct.  
 Sound power emitted to surroundings, measured according to ISO 3741

Project: VZT  
Unit name: AHU4 - Integrovaný DX+Glykolový okruh - Design data

Date: 31/10/2021  
24 / 1.0.20211027.1204652  
Unit ID: AD-10001019410

Frequency band	63	125	250	500	1k	2k	4k	8k	All		
To supply air duct	76	71	72	74	71	69	67	67	dB	77	dB(A)
To outdoor air duct	71	71	73	60	53	51	46	49	dB	66	dB(A)
To extract air duct	71	71	74	60	53	52	50	53	dB	67	dB(A)
To exhaust air duct	77	72	74	76	73	72	70	70	dB	79	dB(A)
To surroundings	69	61	54	58	43	42	39	42	dB	56	dB(A)

Project: VZT  
 Unit name: AHU4 - Integrovaný DX+Glykolový okruh - Design data

Date: 31/10/2021  
 24 / 1.0.20211027.1204652  
 Unit ID: AD-10001019410

GOLD F CX  
 Manufactured by Swegon, Kvänum, Sweden

Dimensioning data		AHU4 - Integrovaný DX+Glykolový okruh
Unit size		035
Air density		1.200 kg/m <sup>3</sup>
Supply air flow		5,000 m <sup>3</sup> /h
Static pressure drop	Outdoor air duct	50 Pa
	Supply air duct	350 Pa
Extract air flow		5,000 m <sup>3</sup> /h
Static pressure drop	Extract air duct	350 Pa
	Exhaust air duct	50 Pa
Climate data		Bratislava, Slovakia
Weather station, reference		BRATISLAVA-STEFANIK, Slovakia
Design outdoor temperature, summer		32.0 °C
Design outdoor humidity, summer		40 %
Design outdoor temperature, winter		-16.0 °C
Design outdoor humidity, winter		90 %
Supply air temperature, summer		17.0 °C
Supply air temperature, winter		20.0 °C

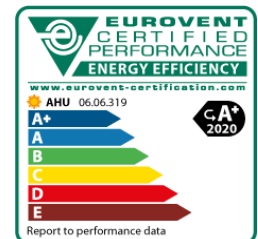
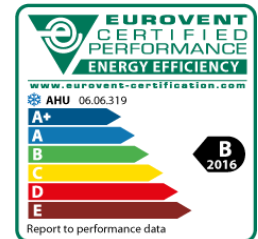

Key Performance Data		
Specific fan power SFPv	Purging flow including leakage, clean filters	1.67 kW/(m <sup>3</sup> /s)
Supply air dry temp. efficiency ratio (+5/+25°C)		70.1 %
Eurovent Energy Efficiency Class	Summer: A+ C, 2020	Winter: B 2016
Eurovent; Fs_Pref:	Summer: 0.84	Winter: 0.83
ErP Commission Regulation (EU) No 1253/2014		Compliant 2018

Project: VZT  
Unit name: AHU4 - Integrovaný DX+Glykolový okruh - Design data

Date: 31/10/2021  
24 / 1.0.20211027.1204652  
Unit ID: AD-10001019410

Casing	
Construction	Frameless, double skinned panels with mineral wool insulation
Panels	56mm thick with 1mm thick steel sheet inside and out. Outer sheet with grey painted finish
Thermal insulation class	T2
Thermal bridging class	TB2
Casing leakage class	L1(M) / L2(R) according to EN 1886:2007 at -400 Pa and +700 Pa
Casing strength	D1(M)
Hygiene	Compliant with the requirements of VDI 6022

Electrical connections	
GOLD F	3-phase, 5-wire, 400 V-10/+15%, 50 Hz, 20 A
Cooling machine, DX	3-phase, 4-wire, 400 V±10%, 50Hz, 25A
Heating coil, electrical, in casing	3*400V+N+PE, 32A

Functional sections viewed in the direction of air flow	Velocity m/s	Air Temperature in/out Winter °C	Air Temperature in/out Summer °C	Power kW	Design Pressure drop Pa	Noise Level dB(A)
<b>Outdoor air duct</b>					-50	66
Damper					-0	
End section					-2	
Cooling machine, DX	0.94		32.0/16.3		-10	
Filter	0.76				-49	
Coil heat exchanger	0.81	-16.0/14.0	16.3/16.3		-52	
Fan				1.23	515	
Heating coil, electrical, in casing		14.7/20.0		8.84	-0	
End section					-2	
<b>Supply air duct</b>					-350	77
<b>Extract air duct</b>					-350	67
End section					-2	
Spacer section					-	
Prefilter					-16	
Filter	0.76				-25	
Coil heat exchanger	0.81	22.0/0.8	26.0/26.0		-52	
Fan				1.21	509	
Cooling machine, DX	0.97		26.7/52.3		-12	
End section					-2	
Damper					-0	
<b>Exhaust air duct</b>					-50	79

Sound power to duct, measured according to ISO 5136  
Noise reduction for function section included to duct.  
Sound power emitted to surroundings, measured according to ISO 3741

Project: VZT  
Unit name: AHU4 - Integrovaný DX+Glykolový okruh - Design data

Date: 31/10/2021  
24 / 1.0.20211027.1204652  
Unit ID: AD-10001019410

Frequency band	63	125	250	500	1k	2k	4k	8k	All	
To supply air duct	76	71	72	74	71	69	67	67	dB	77 dB(A)
To outdoor air duct	71	71	73	60	53	51	46	49	dB	66 dB(A)
To extract air duct	71	71	74	60	53	52	50	53	dB	67 dB(A)
To exhaust air duct	77	72	74	76	73	72	70	70	dB	79 dB(A)
To surroundings	69	61	54	58	43	42	39	42	dB	56 dB(A)

GOLD-Unit with control system

Components are arranged according to airflow direction

### Quantity

### Supply air

<b>1</b>	<b>Damper, TBSA-6-140-060-1-1</b> Damper motor: With spring return Damper blade: Uninsulated Static pressure drop	0 Pa
<b>1</b>	<b>End section, outdoor air</b> Static pressure drop	2 Pa
<b>1</b>	<b>Cooling machine, DX, COOLDX-40-G-1-2-1-1-1</b> Capacity variant	1
	<b>Filter</b> Filter class ePM1 50% (F7) 3x(592x592x520-10), 3x(592x287x520-10) Velocity in the filter section	0.76 m/s
	Recommended design pressure drop	49 Pa
	Initial pressure drop	24 Pa
	Final pressure drop	73 Pa
	<b>Cooling coil</b> No.of tube rows	3
	Fin spacing	2.5 mm
	<i>Air side</i> Electrical power	10.71 kW
	Cooling power	32.96 kW
	Pressure drop, dry	9 Pa
	Pressure drop, wet	10 Pa
	Air velocity	0.94 m/s
	EER	3.08
	Refrigerant type	R410A
	Refrigerant charge circuit 1	3.3 kg
	Refrigerant charge circuit 2	4.0 kg

Project: VZT  
 Unit name: AHU4 - Integrovaný DX+Glykolový okruh - Design data

Date: 31/10/2021  
 24 / 1.0.20211027.1204652  
 Unit ID: AD-10001019410

Supply air temp, compressor step 1	24.1 °C
Supply air temp, compressor step 2	20.9 °C
Supply air temp, compressor step 3	16.3 °C

Supply air side, summer	In	Out	
Air temperature	32.0	16.3	°C
Relative humidity	40	91	%

Extract air side, summer	In	Out	
Air temperature	26.7	52.3	°C
Relative humidity	43	11	%
Amount of drained water		0.142	l/min

Quantity	Product	Article name
1	Drain trap	TBXZ-1-40-3

## 1 Coil heat exchanger, GOLD035FCXP01

The coil heat exchanger is water/glycol filled and ready for use

No.of tube rows	12
No.of circuits	7
Connection number	40 ext.
Fin spacing	2.0 mm
<b>Air side</b>	
Pressure drop	52 Pa
Air velocity	0.81 m/s
Outdoor Air Correction Factor, OACF	1.00
Exhaust Air Transfer Ratio, EATR	< 0.1 %
Supply air dry temp. efficiency ratio (+5/+25°C)	70.1 %
Supply air dry temp. efficiency at balanced airflows (design temp.)	65.3 %
Annual energy efficiency, dry conditions	84.5 %
Annual energy efficiency	86.8 %
LOT without freezing	-16.0 °C
Temperature efficiency, supply air, summer	

Project: VZT  
Unit name: AHU4 - Integrovaný DX+Glykolový okruh - Design data

Date: 31/10/2021  
24 / 1.0.20211027.1204652  
Unit ID: AD-10001019410

Outdoor temperature	Temperature efficiency of supply air according to EN308
-16.0 °C	78.9 %
-11.0 °C	77.8 %
-6.0 °C	76.5 %
-1.0 °C	73.4 %
4.0 °C	67.5 %
9.0 °C	67.6 %
14.0 °C	67.8 %
19.0 °C	67.9 %

Supply air side, winter	In	Out	
Air temperature	-16.0	14.0	°C
Relative humidity	90	10	%
Heating power		50.39	kW

Extract air side, winter	In	Out	
Air temperature	22.0	0.8	°C
Relative humidity	45	98	%

Supply air side, summer	In	Out	
Air temperature	16.3	16.3	°C
Relative humidity	91	91	%

Extract air side, summer	In	Out	
Air temperature	26.0	26.0	°C
Relative humidity	45	45	%

Amount of drained water, extract air, winter

**Liquid side**

Flow of liquid	0.791 l/s
Total sum of liquid pressure losses	92.9 kPa
Total sum of coil liquid volumes	216 l
Recommended lowest set value of shunt temperature	-1.5 °C
Ethylene-glycol	30 %/kg

Quantity	Product	Article name
1	Drain trap	TBXZ-1-40-2

**1**

**Fan**

Fan of type GOLD Wing+

Fan size: 35

Withdrawable fan with integrated airflow measurement

Direct drive with speed controlled EC motor. Efficiency class corresponding to IE5

Isolated with internal flexible connection and rubber anti-vibration mounting

Standard connection, internal



Project: VZT  
 Unit name: AHU4 - Integrovaný DX+Glykolový okruh - Design data

Date: 31/10/2021  
 24 / 1.0.20211027.1204652  
 Unit ID: AD-10001019410

Supply air flow	5,000 m <sup>3</sup> /h
The fan system effect is included in the fan performances	
Design static pressure (wet conditions)	515 Pa
Static pressure rise in the SFPv calculation	489 Pa
Temperature rise caused by the fan	0.7 °C
Min speed	250 rpm
Speed in the SFPv calculation	1,050 rpm
Design speed	1,074 rpm
Max speed	1,635 rpm
Design electric power to motor(s)	1.23 kW
Electric power to motor(s) in the SFPv calculation	1.16 kW
Rated motor power/motor	4.00 kW
Motor option	1
Motor code	DOMEL 749.3.392
Number of fans/motors in the air stream	1
Overall static efficiency drive	58.2 %
Maximum motor efficiency (incl. motor control 91.5%)	94.5 %
Efficiency grade; FMEG, plenum fan, incl. motor control	68.00
Regulation(EU)No 327/2011 overall efficiency	65.2 %
Specific fan power efficiency	0.83 kW/(m <sup>3</sup> /s)

**1 Heating coil, electrical, in casing, TCLE040G02**

3\*400V+N+PE. 30.3A

Capacity variant	21
Static pressure drop	0 Pa
Air velocity	1.11 m/s

	In	Out	
Air temperature	14.7	20.0	°C
Relative humidity	9	7	%

Required coil capacity	8.84 kW
Rated output	21.00 kW
Electrical connections	400

**1 End section, supply air**

Static pressure drop	2 Pa
----------------------	------

**Quantity** **Extract air**

**1 End section, extract air**

Static pressure drop	2 Pa
----------------------	------

Project: VZT  
 Unit name: AHU4 - Integrovaný DX+Glykolový okruh - Design data

Date: 31/10/2021  
 24 / 1.0.20211027.1204652  
 Unit ID: AD-10001019410

**1 Spacer section, TCGA040G01**

Length: 625 mm

**1 Prefilter**

Aluminium filter

3x(596x596x48), 3x(596x292x48)

Velocity in the filter section 0.76 m/s

Recommended design pressure drop 16 Pa

Initial pressure drop 8 Pa

Final pressure drop 24 Pa

**1 Filter**

Filter class ePM10 60% (M5)

3x(592x592x520-10), 3x(592x287x520-10)

Velocity in the filter section 0.76 m/s

Recommended design pressure drop 25 Pa

Initial pressure drop 12 Pa

Final pressure drop 37 Pa

**1 Coil heat exchanger, GOLD035FCXP01**

No. of tube rows 12

No. of circuits 7

Connection number 40 ext.

Fin spacing 2.0 mm

Pressure drop, dry 52 Pa

Air velocity 0.81 m/s

Total sum of coil liquid volumes 216 l

Quantity	Product	Article name
1	Drain trap	TBXZ-1-40-2

**1 Fan**

Fan of type GOLD Wing+

Fan size: 35

Withdrawable fan with integrated airflow measurement

Direct drive with speed controlled EC motor. Efficiency class corresponding to IE5

Isolated with internal flexible connection and rubber anti-vibration mounting

Standard connection, internal

Extract air flow 5,000 m<sup>3</sup>/h

The fan system effect is included in the fan performances

Design static pressure (wet conditions) 509 Pa

Static pressure rise in the SFPv calculation 489 Pa

Project: VZT  
 Unit name: AHU4 - Integrovaný DX+Glykolový okruh - Design data

Date: 31/10/2021  
 24 / 1.0.20211027.1204652  
 Unit ID: AD-10001019410

Temperature rise caused by the fan	0.7 °C
Min speed	250 rpm
Speed in the SFPv calculation	1,049 rpm
Design speed	1,069 rpm
Max speed	1,635 rpm
Design electric power to motor(s)	1.21 kW
Electric power to motor(s) in the SFPv calculation	1.16 kW
Rated motor power/motor	4.00 kW
Motor option	1
Motor code	DOMEL 749.3.392
Number of fans/motors in the air stream	1
Overall static efficiency drive	58.3 %
Maximum motor efficiency (incl. motor control 91.5%)	94.5 %
Efficiency grade; FMEG, plenum fan, incl. motor control	68.00
Regulation(EU)No 327/2011 overall efficiency	65.2 %
Specific fan power efficiency	0.83 kW/(m <sup>3</sup> /s)

**1 Cooling machine, DX, COOLDX-40-G-1-2-1-1**

Capacity variant	1
<b>Condenser coil</b>	
Accessories and other technical data, see supply air	
No.of tube rows	3
Fin spacing	1.8 mm
Pressure drop	12 Pa
Air velocity	0.97 m/s

Quantity	Product	Article name
1	Drain trap	TBXZ-1-40-3

**1 End section, exhaust air**

Static pressure drop	2 Pa
----------------------	------

**1 Damper, TBSA-6-140-060-1-1**

Damper motor: With spring return	
Damper blade: Uninsulated	
Static pressure drop	0 Pa

Quantity

Accessories

Project: VZT  
Unit name: AHU4 - Integrovaný DX+Glykolový okruh - Design data

Date: 31/10/2021  
24 / 1.0.20211027.1204652  
Unit ID: AD-10001019410

### Design data, Supply air

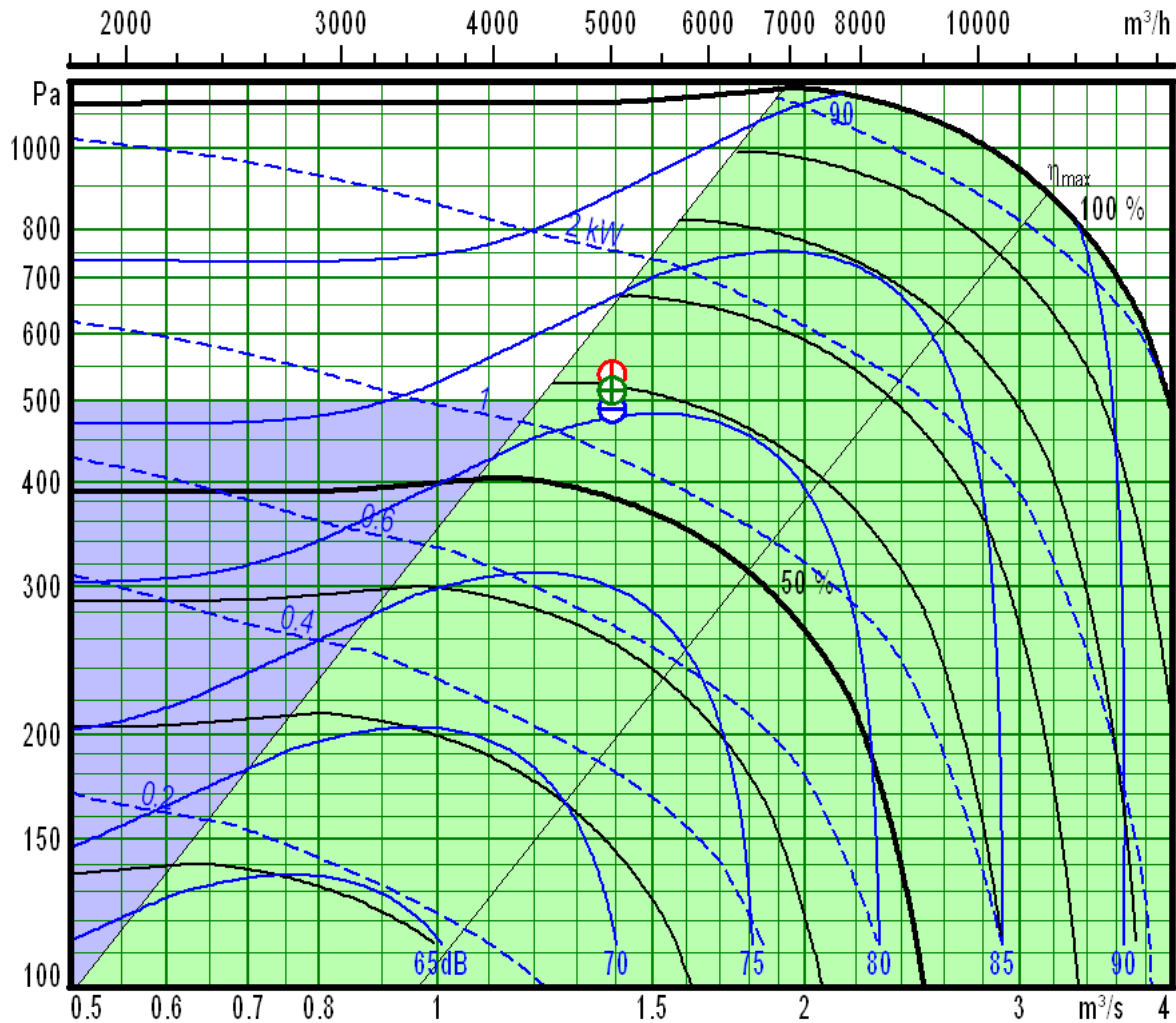

The chart shows the static pressure rise of the fan in Pa relative air flow in  $m^3/s$  and in  $m^3/h$  at different relative speeds (minimum speed = 0% and maximum speed = 100 %). One can also read electrical power from mains in kW and sound power level at fan outlet in dB.

Green area: Recommended working range for sizing

Blue area: Permissible operating range for low airflow in demand controlled ventilation systems (VAV) with pressure control.

Red circle with a vertical line: max operating point

Green circle with a cross: design operating point

Blue circle with a horizontal line: clean operating point

Fan of type GOLD Wing+		Fan size: 35	
Direct drive with speed controlled EC motor. Efficiency class corresponding to IE5			
Speed	Min speed:	Max speed:	rpm
	250	1635	
Rated motor power/motor		4.00	kW

Project: VZT  
Unit name: AHU4 - Integrovaný DX+Glykolový okruh - Design data

Date: 31/10/2021  
24 / 1.0.20211027.1204652  
Unit ID: AD-10001019410

Design data, Extract air

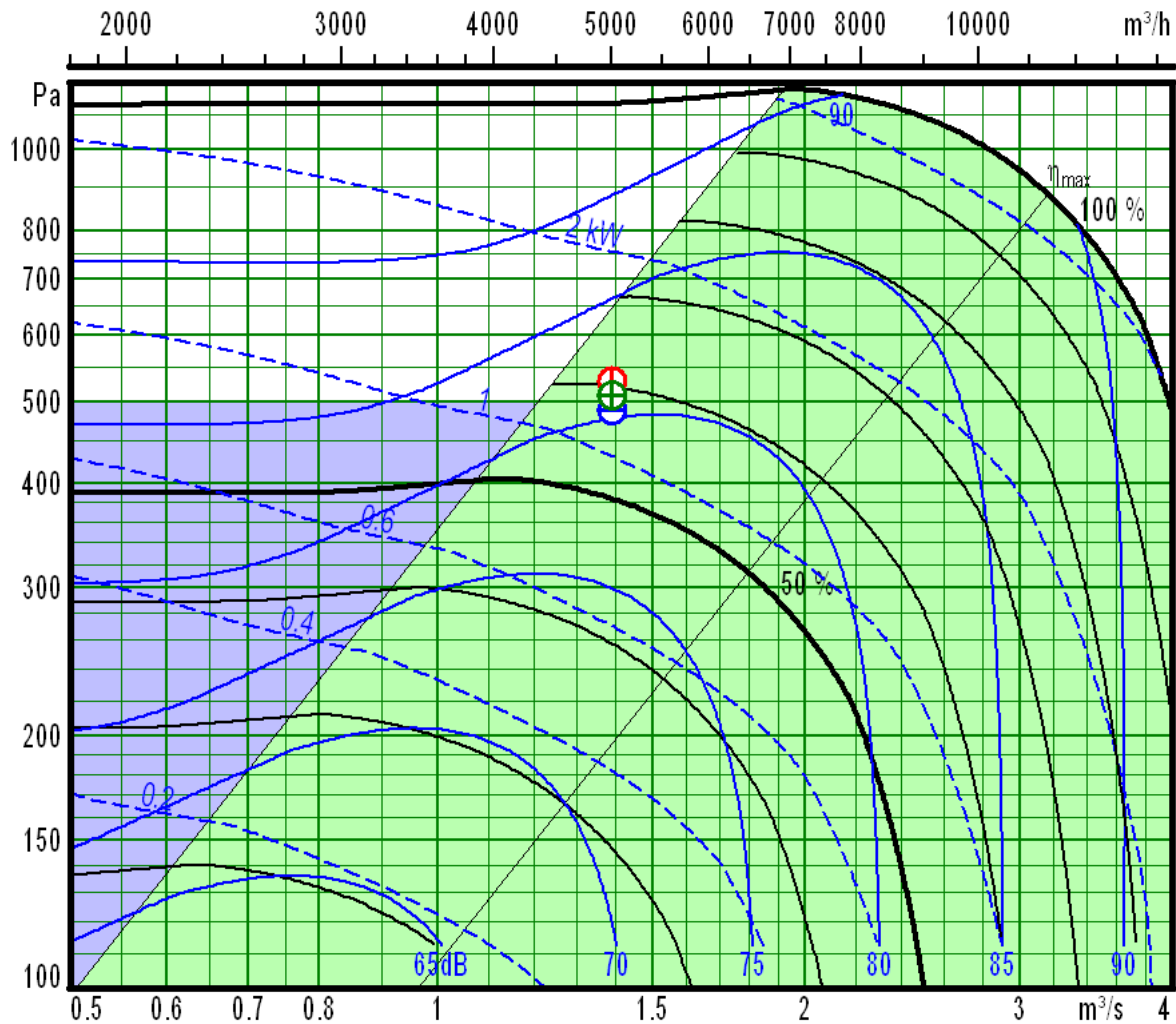

The chart shows the static pressure rise of the fan in Pa relative air flow in  $m^3/s$  and in  $m^3/h$  at different relative speeds (minimum speed = 0% and maximum speed = 100 %). One can also read electrical power from mains in kW and sound power level at fan outlet in dB.

Green area: Recommended working range for sizing

Blue area: Permissible operating range for low airflow in demand controlled ventilation systems (VAV) with pressure control.

Red circle with a vertical line: max operating point

Green circle with a cross: design operating point

Blue circle with a horizontal line: clean operating point

Fan of type GOLD Wing+		Fan size: 35	
Direct drive with speed controlled EC motor. Efficiency class corresponding to IE5			
Speed	Min speed:	Max speed:	rpm
	250	1635	
Rated motor power/motor		4.00	kW

Project: VZT  
Unit name: AHU4 - Integrovaný DX+Glykolový okruh - Design data

Date: 31/10/2021  
24 / 1.0.20211027.1204652  
Unit ID: AD-10001019410

#### GOLD F CX

Unit size	035
Supply air flow	5,000 m <sup>3</sup> /h
Pressure drop, supply air	400 Pa
Design electric power to motor(s), Supply air fan	1.23 kW
Extract air flow	5,000 m <sup>3</sup> /h
Pressure drop, extract air	400 Pa
Design electric power to motor(s), Extract air fan	1.21 kW

Non-residential ventilation unit (exception: multi dwelling residential buildings)

Unit type: bidirectional ventilation unit; NVRU, BVU

Run-around coil exchanger

Supply air dry temp. efficiency ratio (+5/+25°C and 25% ethylene glycol) (Requirement: 2018: 68 %): 71.8 %

Maximum internal leakage (pressurisation test) < 0.1 %

ErP Commission Regulation (EU) No 1253/2014  
The air handling unit meets the requirements in 2018

Supply air	
Face velocity, filter section	0.76 m/s
Energy perf, 6000 h (filter class ePM1 50% (F7) or better)	698 kWh/year
Filter class (ePM1 50% (F7) or better)	F7
Reference filter; ePM1 50% (F7)	24 Pa
HRS	52 Pa
Casing; inlet	2 Pa
Casing; outlet	2 Pa
Casing; fan system losses	0 Pa
(The fan system effect is included in the fan performances)	
Overall static fan efficiency at the current working point	58.2 %

Extract air	
Face velocity, filter section	0.76 m/s
Energy perf, 6000 h (filter class ePM10 60% (M5) or better)	354 kWh/year
Filter class (ePM10 60% (M5) or better)	M5
Reference filter; ePM10 60% (M5)	12 Pa
HRS	52 Pa
Casing; inlet	2 Pa
Casing; outlet	2 Pa
Casing; fan system losses	0 Pa
(The fan system effect is included in the fan performances)	
Overall static fan efficiency at the current working point	58.3 %

Project: VZT  
Unit name: AHU4 - Integrovaný DX+Glykolový okruh - Design data

Date: 31/10/2021  
24 / 1.0.20211027.1204652  
Unit ID: AD-10001019410

Efficiency bonus E 2018	115 W/(m <sup>3</sup> /s)
Filter correction F 2018	0 W/(m <sup>3</sup> /s)
Internal specific fan power, SFPint	254 W/(m <sup>3</sup> /s)
Internal specific fan power, required 2018, SFPint_limit	1,507 W/(m <sup>3</sup> /s)

Type of drive: Direct drive with speed controlled EC motor. Efficiency class corresponding to IE5	
Visual filter warning is available in the hand terminal provided	
Sound power emitted to surroundings, measured according to ISO 3741	56 dB(A)
Disassembly instructions: <a href="https://www.swegon.com/globalassets/_product-documents/air-handling-units/gold-version-f/general/_multi/recycling_instruction-air-handling-units.pdf">https://www.swegon.com/globalassets/_product-documents/air-handling-units/gold-version-f/general/_multi/recycling_instruction-air-handling-units.pdf</a>	

Project: VZT  
Unit name: AHU4 - Integrovaný DX+Glykolový okruh - Design data

Date: 31/10/2021  
24 / 1.0.20211027.1204652  
Unit ID: AD-10001019410

GOLD F CX  
Manufactured by Swegon, Kvänum, Sweden

Dimensioning data	AHU4 - Integrovaný DX+Glykolový okruh	
Unit size	035	
Air density	1.200 kg/m <sup>3</sup>	
Supply air flow	5,000 m <sup>3</sup> /h	
Static pressure drop	Outdoor air duct	50 Pa
	Supply air duct	350 Pa
Extract air flow	5,000 m <sup>3</sup> /h	
Static pressure drop	Extract air duct	350 Pa
	Exhaust air duct	50 Pa
Climate data	Bratislava, Slovakia	
Weather station, reference	BRATISLAVA-STEFANIK, Slovakia	
Design outdoor temperature, summer	32.0 °C	
Design outdoor humidity, summer	40 %	
Design outdoor temperature, winter	-16.0 °C	
Design outdoor humidity, winter	90 %	
Supply air temperature, summer	17.0 °C	
Supply air temperature, winter	20.0 °C	

Temperature data, Energy	Design data
Supply air temperature, summer	17.0 °C
Supply air temperature, winter	20.5 °C
Extract air temperature, summer	26.0 °C
Extract air temperature, winter	22.0 °C
Post heating, outdoor temperature limit	15.0 °C



Project: VZT  
Unit name: AHU4 - Integrovaný DX+Glykolový okruh - Design data

Date: 31/10/2021  
24 / 1.0.20211027.1204652  
Unit ID: AD-10001019410

Operating data	Design data
Supply air fan	After HEX
Airflow	5,000 m <sup>3</sup> /h
Pressure increase	515 Pa
Electric power fan	1.23 kW
Temp. Inc. Fan	0.7 °C
Extract air fan	After HEX
Airflow	5,000 m <sup>3</sup> /h
Pressure increase	509 Pa
Electric power fan	1.21 kW
Temp. Inc. Fan	0.7 °C
Heat exchanger	Coil heat exchanger
Dry-bulb temperature efficiency of supply air	67.5 %
Cooling recovery	No

Electrical energy	Design data
Fan motors	21,400 kWh/year
Electric energy, comparison without energy recovery	19,200 kWh/year

Thermal energy	Design data
With energy recovery	17,300 kWh/year
Without energy recovery	131,000 kWh/year

Cooling energy	Design data
With energy recovery (total/sensible)	17,000 /14,600 kWh/year
Without energy recovery (total/sensible)	17,000 /14,600 kWh/year

Energy prices	Design data
Energy price, Electrical	0.540 EUR/kWh
Energy price, Heat	0.480 EUR/kWh
Energy price, Cooling	0.540 EUR/kWh
Estimated annual price increase, Electrical	2 %
Estimated annual price increase, Heat	2 %
Estimated annual price increase, Cooling	2 %
Period in use	20 year
Calculated interest rate	6 %

Project: VZT  
Unit name: AHU4 - Integrovaný DX+Glykolový okruh - Design data

Date: 31/10/2021  
24 / 1.0.20211027.1204652  
Unit ID: AD-10001019410

Costs	
Electric energy fans	11,600 EUR/year
Electric energy pump (coil hx)	0 EUR/year
Heat cost (post heating)	8,300 EUR/year
Cooling cost (post cooling)	9,160 EUR/year
Total cost of energy consumption	29,000 EUR/year

Cost comparison without energy recovery	
Electric energy fans	10,400 EUR/year
Heating Cost	62,900 EUR/year
Cooling cost	9,160 EUR/year
Total energy cost, without energy recovery	82,500 EUR/year

Life cycle energy cost	
Life cycle energy costs, electricity	157,000 EUR
Life cycle energy costs, heating	113,000 EUR
Life cycle energy costs, cooling	124,000 EUR
Total	394,000 EUR

Life cycle energy cost, without energy recovery	
Life cycle energy costs, electricity, without energy recovery	141,000 EUR
Life cycle energy costs, heating, without energy recovery	855,000 EUR
Life cycle energy costs, cooling, without energy recovery	124,000 EUR
Total	1,120,000 EUR

Project: VZT  
Unit name: AHU4 - Integrovaný DX+Glykolový okruh - Design data

Date: 31/10/2021  
24 / 1.0.20211027.1204652  
Unit ID: AD-10001019410

Operating hours																								
Day \ Hour	1	2	3	4	5	6	7	8	9	10	11	12	13	14	15	16	17	18	19	20	21	22	23	24
Monday	■	■	■	■	■	■	■	■	■	■	■	■	■	■	■	■	■	■	■	■	■	■	■	■
Tuesday	■	■	■	■	■	■	■	■	■	■	■	■	■	■	■	■	■	■	■	■	■	■	■	■
Wednesday	■	■	■	■	■	■	■	■	■	■	■	■	■	■	■	■	■	■	■	■	■	■	■	■
Thursday	■	■	■	■	■	■	■	■	■	■	■	■	■	■	■	■	■	■	■	■	■	■	■	■
Friday	■	■	■	■	■	■	■	■	■	■	■	■	■	■	■	■	■	■	■	■	■	■	■	■
Saturday	■	■	■	■	■	■	■	■	■	■	■	■	■	■	■	■	■	■	■	■	■	■	■	■
Sunday	■	■	■	■	■	■	■	■	■	■	■	■	■	■	■	■	■	■	■	■	■	■	■	■

Design data  
 No operation

Project: VZT  
Unit name: AHU4 - Integrovaný DX+Glykolový okruh - Design data

Date: 31/10/2021  
24 / 1.0.20211027.1204652  
Unit ID: AD-10001019410

Design data

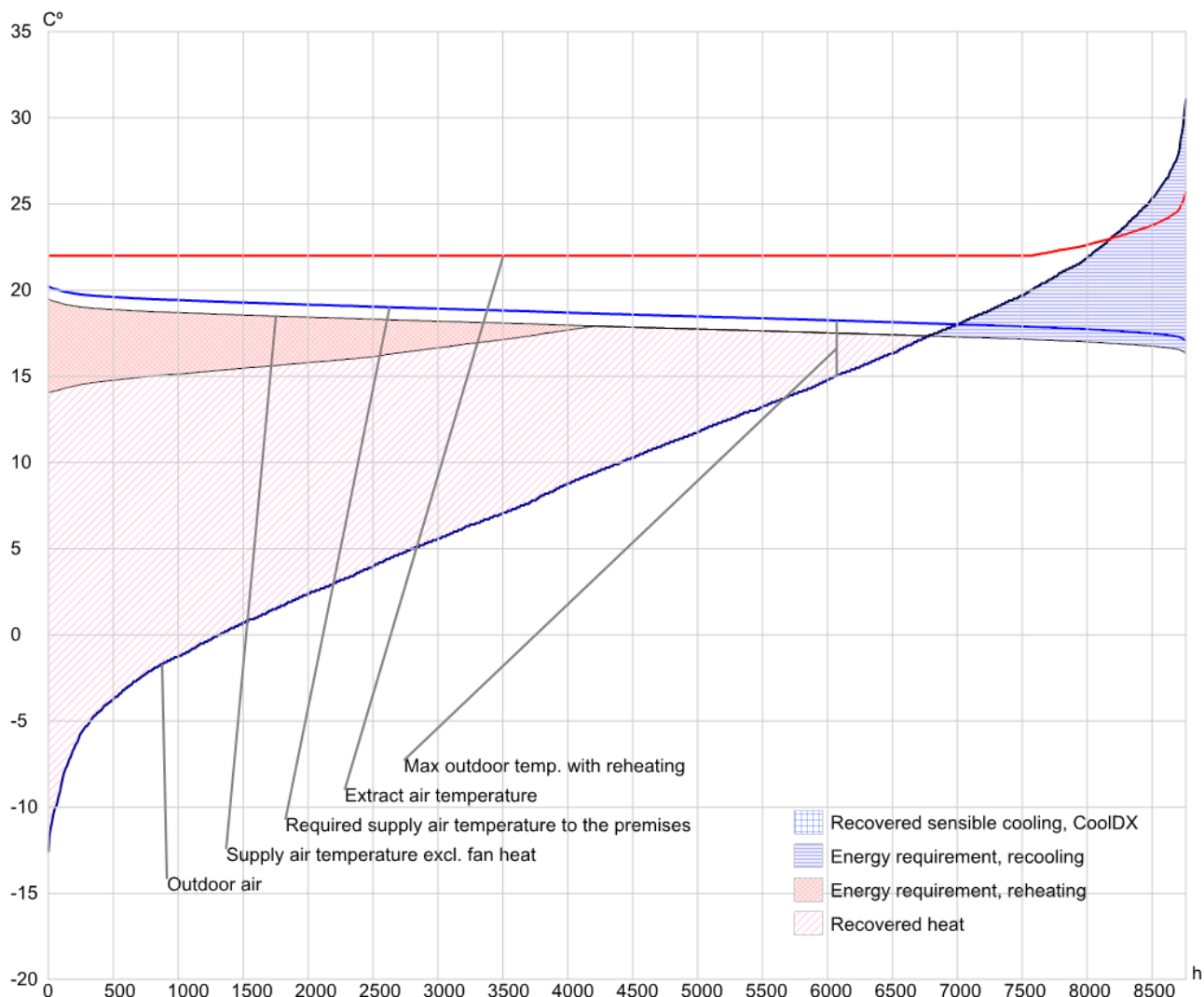

Project: VZT  
Unit name: AHU4 - Integrovaný DX+Glykolový okruh - Design data

Date: 31/10/2021  
24 / 1.0.20211027.1204652  
Unit ID: AD-10001019410

Power consumption

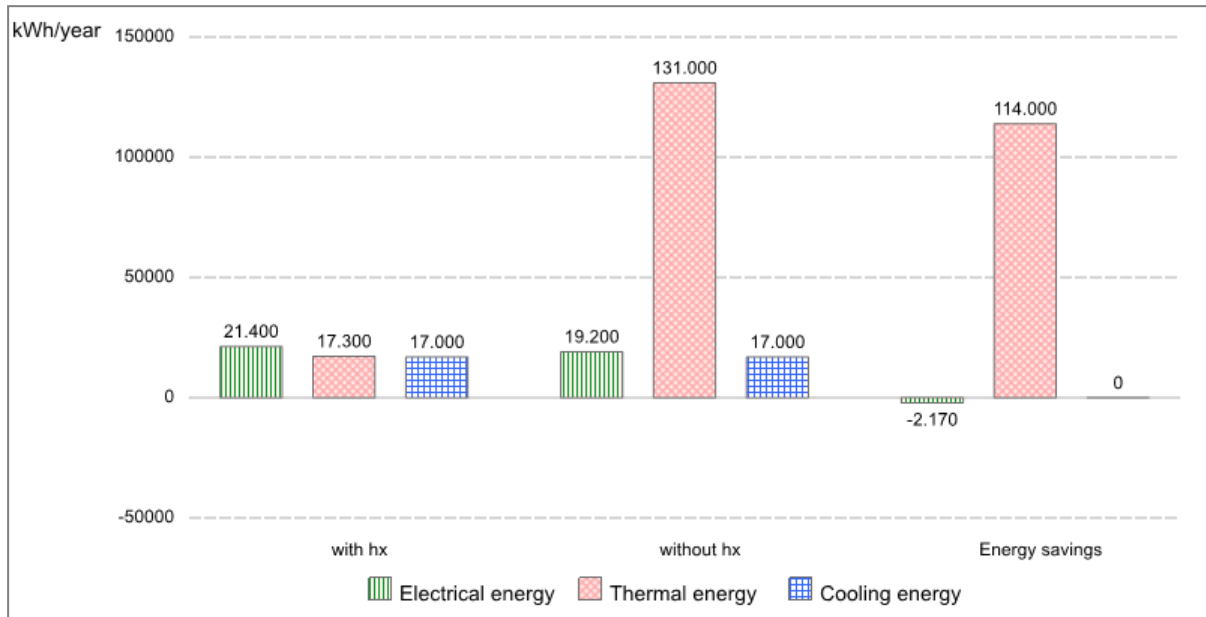

Power consumption with hx (kWh/year)

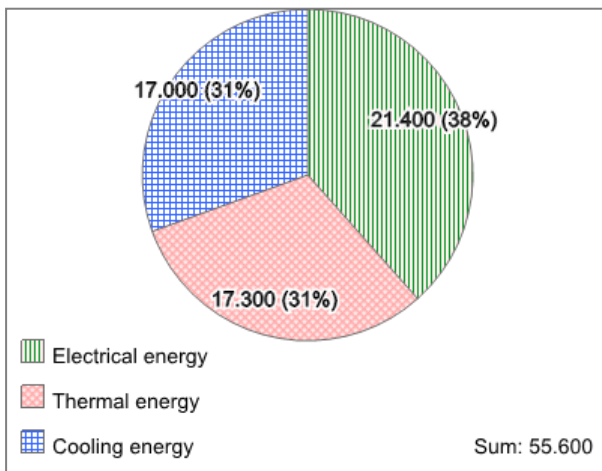

Power consumption without hx (kWh/year)

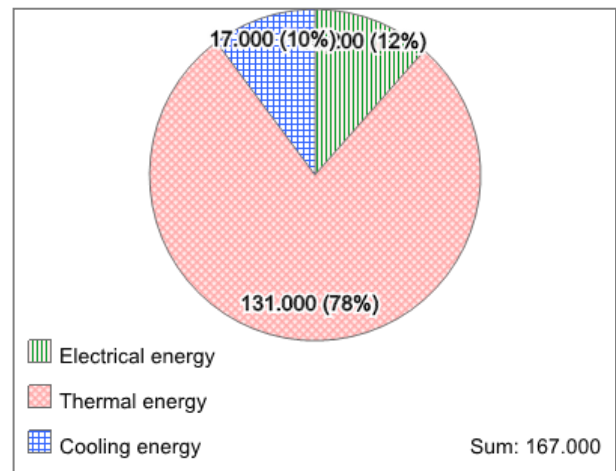

Project: VZT  
Unit name: AHU4 - Integrovaný DX+Glykolový okruh - Design data

Date: 31/10/2021  
24 / 1.0.20211027.1204652  
Unit ID: AD-10001019410

Energy

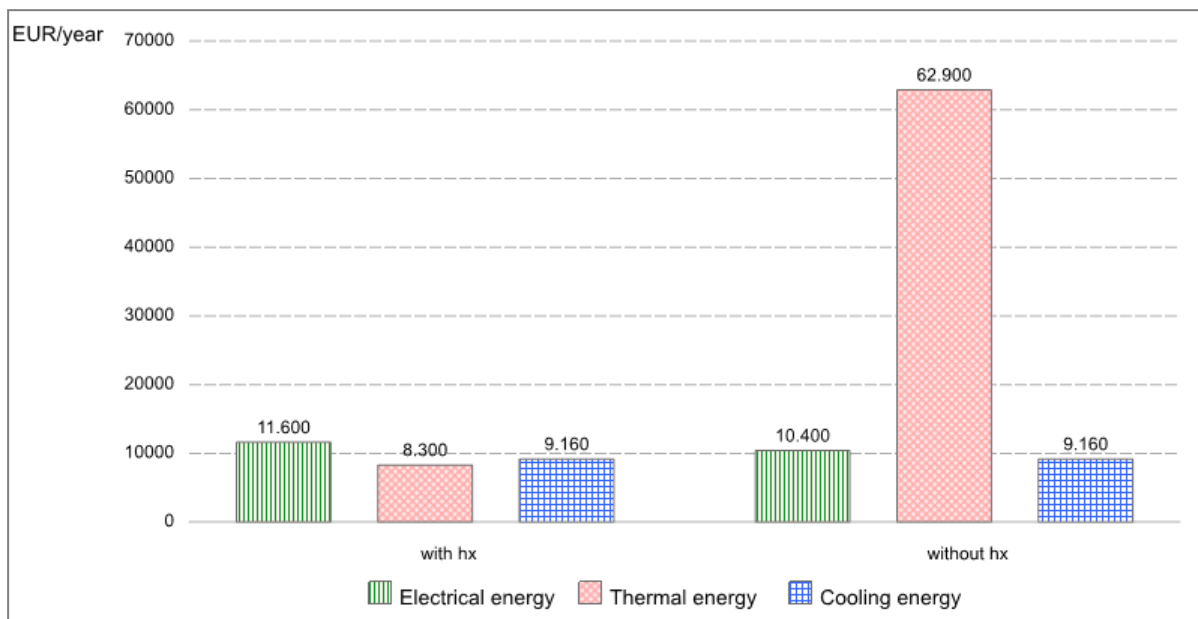

Energy with hx (EUR/year)

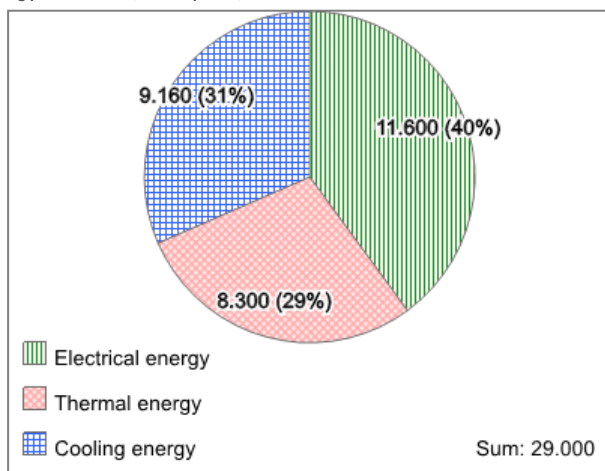

Energy without hx (EUR/year)

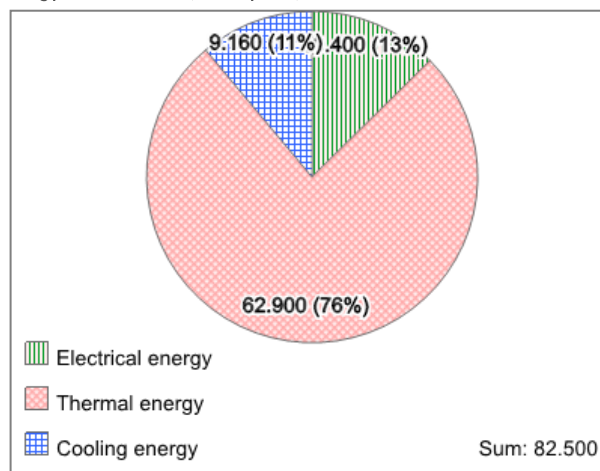

Project: VZT  
Unit name: AHU4 - Integrovaný DX+Glykolový okruh - Design data

Date: 31/10/2021  
24 / 1.0.20211027.1204652  
Unit ID: AD-10001019410

Life cycle energy cost

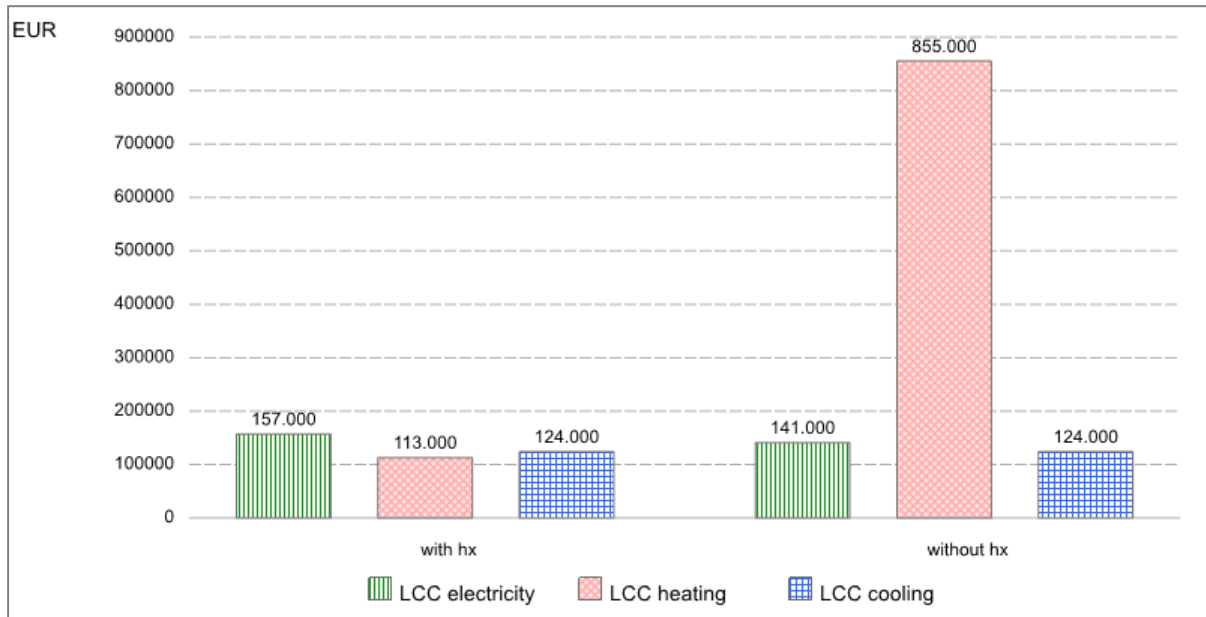

Life cycle energy cost with hx (EUR)

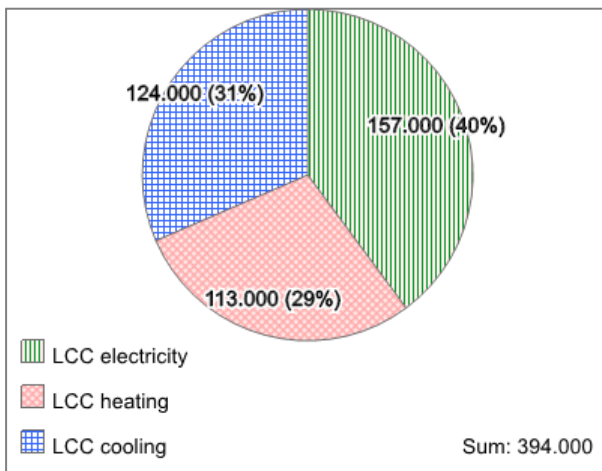

Life cycle energy cost without hx (EUR)

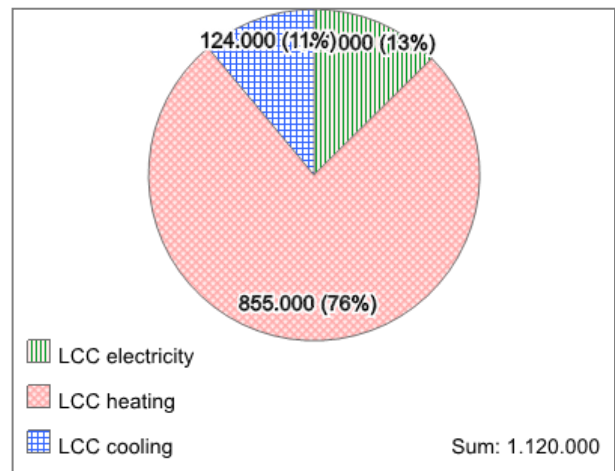

Project: VZT  
Unit name: AHU4 - Integrovaný DX+Glykolový okruh

Date: 31/10/2021  
24 / 1.0.20211027.1204652  
Unit ID: AD-10001019410

GOLD 05-30 Position and number of supporting feet.

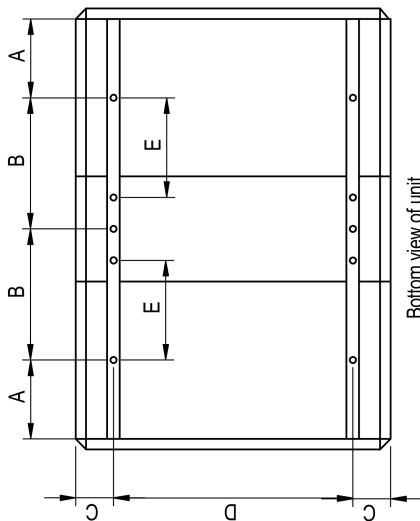

GOLD	A (mm)	B (mm)	C (mm)	D (mm)	E (mm)	Number of supporting feet
05RX	118	580	100	624		6
05RX S	283	565	100	624		6
05PX	375	740	100	624		6
05PX S	283	933	100	624		6
08RX	123	625	100	794		6
08RX S	298	582	100	794		6
08PX	400	800	100	794		6
08PX S	298	1057	100	794		6
12RX	298	580	100	998		6
12PX	298	1113	100	998		6
20RX	353	636	100	1199		6
20PX	353		100	1199	428	8
30RX	398	680	100	1399		6
30PX	398		100	1399	478	8

GOLD 40-80

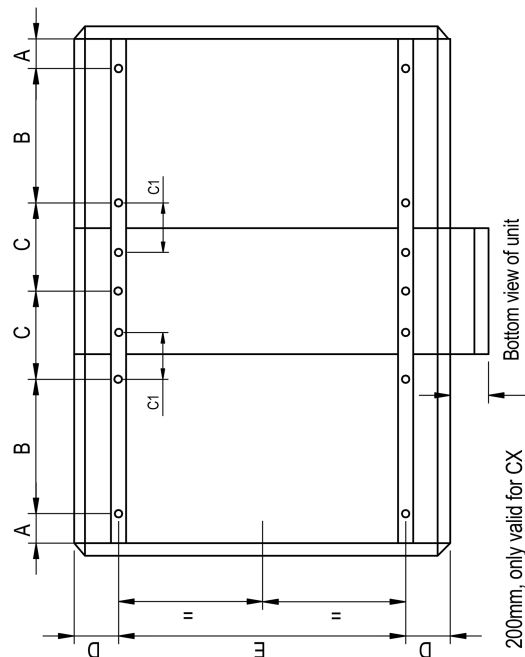

GOLD	A (mm)	B (mm)	C (mm)	C1 (mm)	D (mm)	E (mm)	Number of supporting feet
40RX	92	804	374		100	1789	10
40CX	92	804		182	100	1789	12
40PX	92	804		492	100	1789	12
60RX	92	804	374		100	2117	10
60CX	92	804		182	100	2117	12
80RX	256	710	539		98	2441	10
80CX	256	710		347	98	2441	12



Project: VZT  
Unit name: AHU4 - Integrovaný DX+Glykolový okruh

Date: 31/10/2021  
24 / 1.0.20211027.1204652  
Unit ID: AD-10001019410

---

Project: VZT  
Unit name: AHU4 - Integrovaný DX+Glykolový okruh

Date: 31/10/2021  
24 / 1.0.20211027.1204652  
Unit ID: AD-10001019410

TCSA		TCDA					TCGA														
A (mm)	A1 (mm)	B (mm)	C (mm)	D (mm)	E (mm)	Number of supporting feet	A (mm)	A1 (mm)	B (mm)	C (mm)	D (mm)	E (mm)	Number of supporting feet	A (mm)	A1* (mm)	B (mm)	C (mm)	D (mm)	E (mm)	Number of supporting feet	
04-08	200	100	100	114	114	2	114	100	100	100	100	114	4	108	55/283	100	100	100	1196	1245	2
12	200	100	100	114	114	2	114	100	100	100	100	114	4	108	55/283	100	100	100	1196	1245	2
14/20	200	100	100	114	114	2	114	100	100	100	100	114	4	108	55/283	100	100	100	1196	1245	2
25/30	200	100	100	114	114	2	114	100	100	100	100	114	4	108	55/283	100	100	100	1196	1245	2
35/40	200	100	100	114	114	2	114	100	100	100	100	114	4	108	55/283	100	100	100	1196	1245	2
50/60	200	100	100	114	114	2	114	100	100	100	100	114	4	108	55/283	100	100	100	1196	1245	2
70/80	200	98	98	114	114	2	114	98	98	98	98	114	4	108	55/283	98	98	98	1196	1245	2
120	48	99.5	1048	108	108	N/A	108	99.5	1048	108	108	1196	N/A	108	55/283	99	1048	108	1196	1245	N/A

TCKA		TCKC					TCLA/TCLE														
A (mm)	A1* (mm)	B (mm)	C (mm)	D (mm)	E (mm)	Number of supporting feet	A (mm)	A1* (mm)	B (mm)	C (mm)	D (mm)	E (mm)	Number of supporting feet	A (mm)	A1 (mm)	B (mm)	C (mm)	D (mm)	E (mm)	Number of supporting feet	
04-08	114	100	100	114	114	4	114	100	100	100	100	114	4	108	200	100	100	100	1196	1245	2
12	114	100	100	114	114	4	114	100	100	100	100	114	4	108	200	100	100	100	1196	1245	2
14/20	114	100	100	114	114	4	114	100	100	100	100	114	4	108	200	100	100	100	1196	1245	2
25/30	114	100	100	114	114	4	114	100	100	100	100	114	4	108	200	100	100	100	1196	1245	2
35/40	114	100	100	114	114	4	114	100	100	100	100	114	4	108	200	100	100	100	1196	1245	2
50/60	114/283	100	100	114	114	2	114/283	100	100	100	100	114	4	108	283	100	100	100	1196	1245	2
70/80	114/283	98	98	114	114	2	114/283	98	98	98	98	114	4	108	283	98	98	98	1196	1245	2
120	108	99.5	1048	108	108	N/A	108	99.5	1048	108	108	1196	N/A	108	283	99.5	1048	108	1196	1245	N/A

TCLE		TCIA					TCFB														
A (mm)	A1* (mm)	B (mm)	C (mm)	D (mm)	E (mm)	Number of supporting feet	A (mm)	A1* (mm)	B (mm)	C (mm)	D (mm)	E (mm)	Number of supporting feet	A (mm)	A1 (mm)	B (mm)	C (mm)	D (mm)	E (mm)	Number of supporting feet	
04-08	114	100	100	114	114	4	114	55/283	100	100	100	114	4	108	360	100	100	100	1196	1245	2
12	114	100	100	114	114	4	114	55/283	100	100	100	114	4	108	360	100	100	100	1196	1245	2
14/20	114	100	100	114	114	4	114	55/283	100	100	100	114	4	108	360	100	100	100	1196	1245	2
25/30	114/283	100	100	114	114	2	114	55/283	100	100	100	114	4	108	360	100	100	100	1196	1245	2
35/40	114/283	100	100	114	114	2	114	55/283	100	100	100	114	4	108	360	100	100	100	1196	1245	2
50/60	114	100	100	114	114	4	114	55/283	100	100	100	114	4	108	360	100	100	100	1196	1245	2
70/80	114	98	98	114	114	4	114	55/283	98	98	98	114	4	108	360	98	98	98	1196	1245	2
120	108	99.5	1048	108	108	N/A	108	55/283	99.5	1048	108	1196	N/A	108	360	99	1048	108	1196	1245	N/A

Accessories 05-120  
Position and number  
of supporting feet

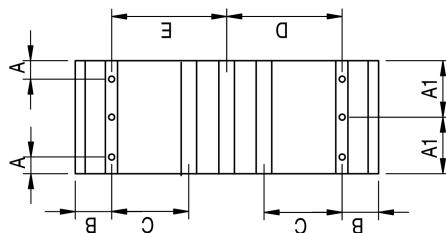

Bottom view of unit

\* Accessories are available in two different lengths.

TCEK		TCLK					TCKA/KC, TCLE and TCIA					
A (mm)	A1 (mm)	B (mm)	C (mm)	D (mm)	E (mm)	Number of supporting feet	A* (mm)	B (mm)	C (mm)	D (mm)	E (mm)	Number of supporting feet
114	100	100	100	114	114	8	114	100	100	100	114	8
114	100	100	100	114	114	8	114	100	100	100	114	8
114	100	100	100	114	114	8	55/114	100	100	100	114	8
114	100	100	100	114	114	8	55/114	100	100	100	114	8
						8	For dimensions see TCKA/KC, TCLE and TCIA					
						8						
						N/A						

Project: VZT  
Unit name: AHU4 - Integrovaný DX+Glykolový okruh

Date: 31/10/2021  
24 / 1.0.20211027.1204652  
Unit ID: AD-10001019410

---

Project: VZT  
Unit name: AHU4 - Integrovaný DX+Glykolový okruh

Date: 31/10/2021  
24 / 1.0.20211027.1204652  
Unit ID: AD-10001019410

## GOLD, version F

### GOLD, sizes 004-060

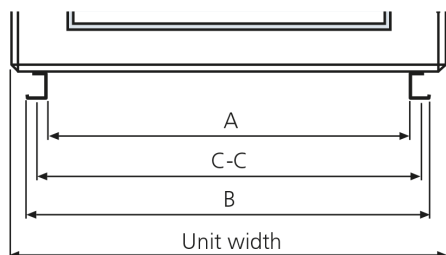

### GOLD RX/PX/CX

Size	C-C (mm)	A (mm)	B (mm)	Unit width (mm)	Unit length, incl. end walls (mm)				
					RX	RX Top	PX	PX Top	CX
004/005, common casing*	624	579	669	825	1499	1600	2333	–	–
004/005, split version	624	579	669	825	1799	–	2534	2534	–
007/008, common casing*	794	749	839	995	1619	1720	2503	–	–
007/008, split version	794	749	839	995	1860	–	2811	2811	–
011/012	998	953	1043	1199	1859	2219	2925	3285	–
014/020	1199	1154	1244	1400	2080	2643	3351	3914	–
025/030	1399	1354	1444	1600	2261	2643	3825	4208	–
035/040	1789	1744	1834	1990**	2642	–	4477	–	2977
050/060	2117	2072	2162	2318**	2642	–	–	–	2977

### GOLD SD

Size	C-C (mm)	A (mm)	B (mm)	Unit width (mm)	Unit length, incl. end walls (mm)		
					Fan	Fan+filter	Fan+filter+coil
004/005, common casing***	624	579	669	825**	1120	1120	1955
004/005, split version	624	579	669	825**	809	1529	2364
007/008, common casing***	794	749	839	995**	1214	1214	2049
007/008, split version	794	749	839	995**	809	1529	2364
011/012, common casing	998	953	1043	1199**	1404	1404	2239
011/012, split version	998	953	1043	1199**	878	1598	2433
014/020	1199	1154	1244	1400**	1040	1875	2710
025/030	1399	1354	1444	1600**	1144	1978	2813
035/040	1789	1744	1834	1990**	1253	2088	2988
050/060	2117	2072	2162	2318**	1253	2088	2988

\* Base beams are optional.

\*\* Heat recovery coil section width = Unit width + 200 mm. (CX and SD only)

\*\*\* Base beams are standard if the AHU features heat recovery coil. Base beams are optional if the AHU does not feature heat recovery coil.

Project: VZT  
Unit name: AHU4 - Integrovaný DX+Glykolový okruh

Date: 31/10/2021  
24 / 1.0.20211027.1204652  
Unit ID: AD-10001019410

## GOLD, version F

### GOLD, size 070/080

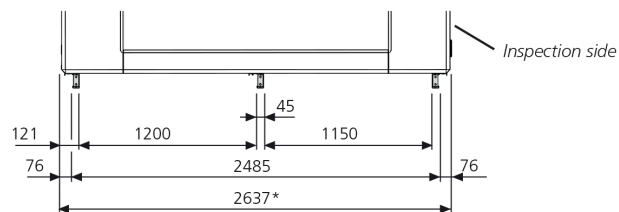

\* Heat recovery coil section width = Unit width + 200 mm. (CX and SD only)

#### GOLD RX/CX

Size	Unit length, incl. end walls (mm)	
	RX	CX
070/080	3112	3447

#### GOLD SD

Size	Unit length, incl. end walls (mm)		
	Fan	Fan+filter	Fan+filter+coil
070/080	1325	2547	3447

### GOLD, size 100/120

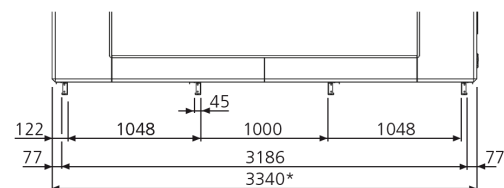

\* Heat recovery coil section width = Unit width + 200 mm. (CX and SD only)

#### GOLD RX/CX

Size	Unit length, incl. end walls (mm)	
	RX	CX
100/120	3322	3322

#### GOLD SD

Size	Unit length, incl. end walls (mm)		
	Fan	Fan+filter	Fan+filter+coil
100/120	1681	2752	3322

AHU Design  
Sketch: Inspection side

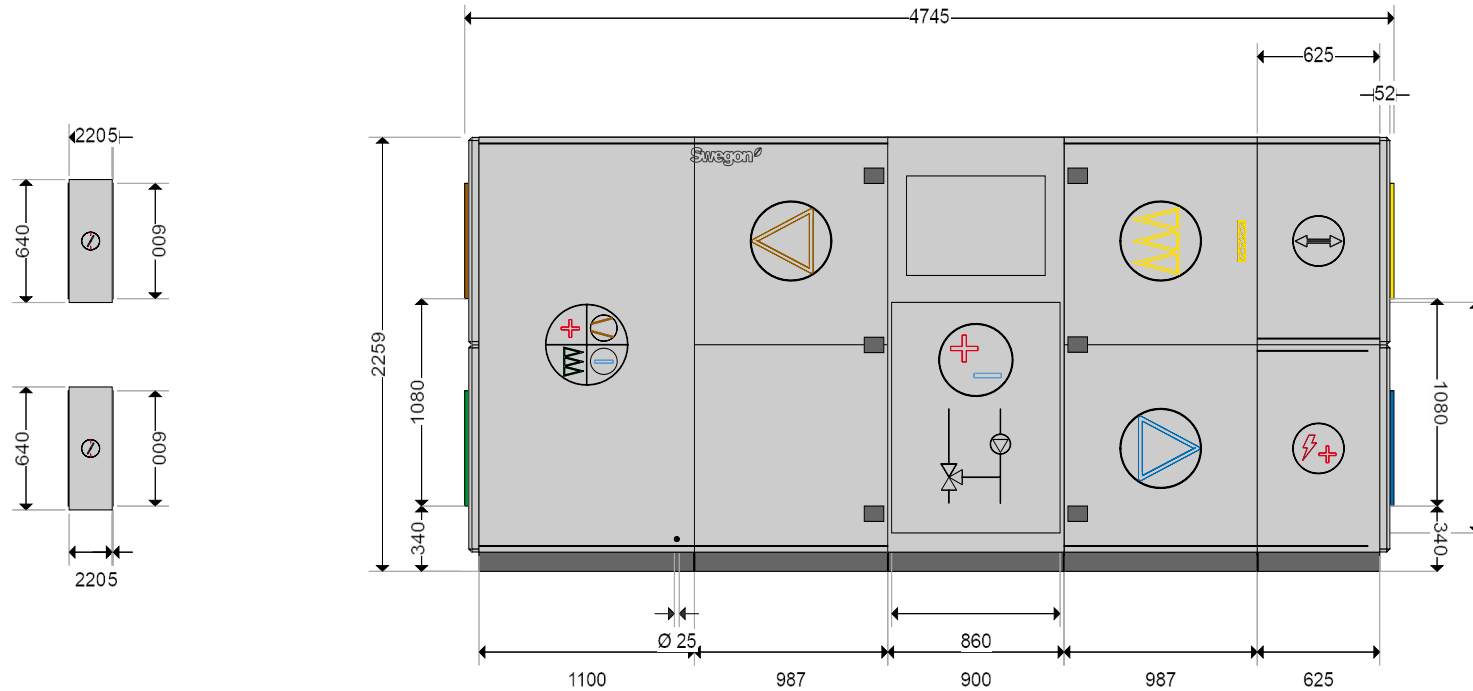

GOLD F CX	
Unit size	035
Unit weight	2,813 kg
Duct Component Weight	64 kg
Length, max	4,745 mm
Height, max	2,259 mm
Width, max	2,890 mm

Connection size	
outdoor air	1,400 x 600 mm
supply air	1,400 x 600 mm
extract air	1,400 x 600 mm
exhaust air	1,400 x 600 mm

Project: VZT  
 Unit name: AHU4 - Integrovaný  
 DX+Glykolový okruh  
 Unit ID: AD-10001019410  
 24 / 1.0.20211027.1204652  
 Date: 31/10/2021

- Outdoor air
- Supply air
- Extract air
- Exhaust air



AHU Design  
Sketch: Rear side

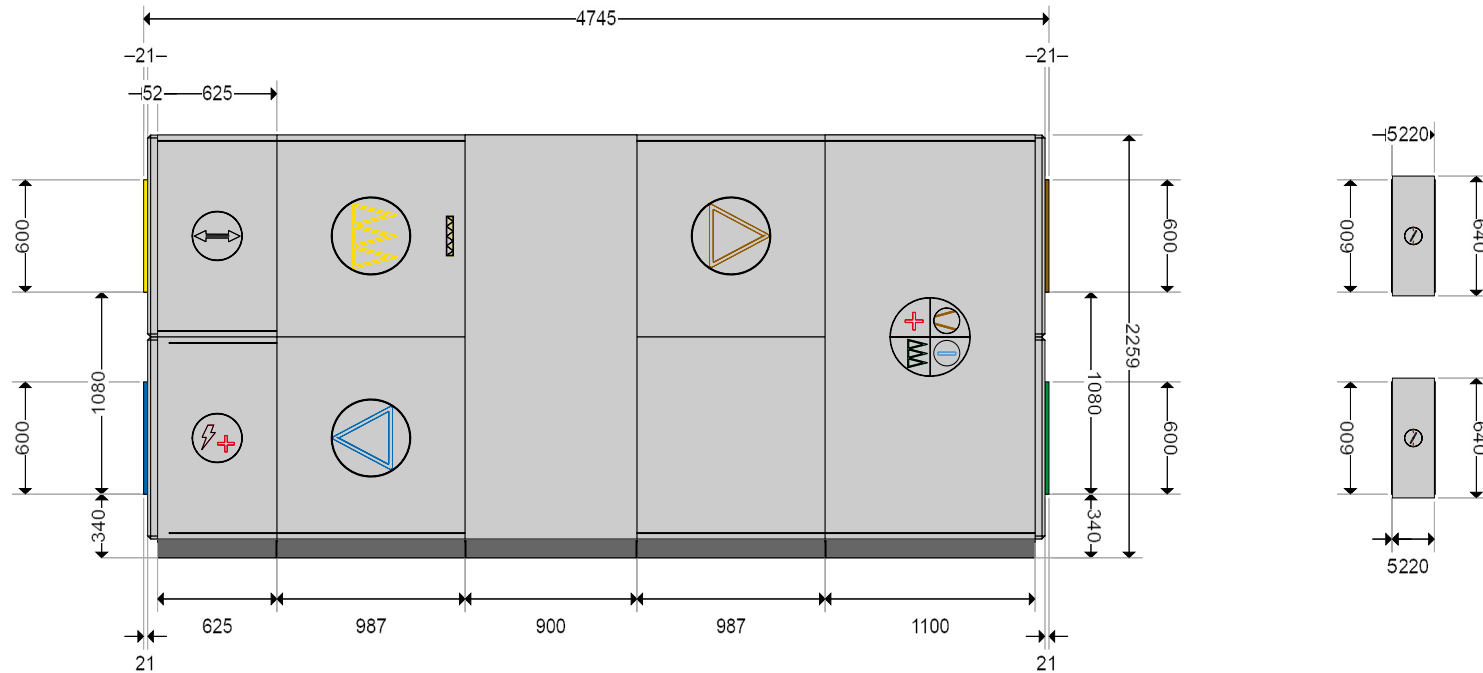

GOLD F CX	
Unit size	035
Unit weight	2,813 kg
Duct Component Weight	64 kg
Length, max	4,745 mm
Height, max	2,259 mm
Width, max	2,890 mm

Connection size	
outdoor air	1,400 x 600 mm
supply air	1,400 x 600 mm
extract air	1,400 x 600 mm
exhaust air	1,400 x 600 mm

Project: VZT  
 Unit name: AHU4 - Integrovaný  
 DX+Glykolový okruh  
 Unit ID: AD-10001019410  
 24 / 1.0.20211027.1204652  
 Date: 31/10/2021

- Outdoor air
- Supply air
- Extract air
- Exhaust air



AHU Design  
Sketch: Left-hand

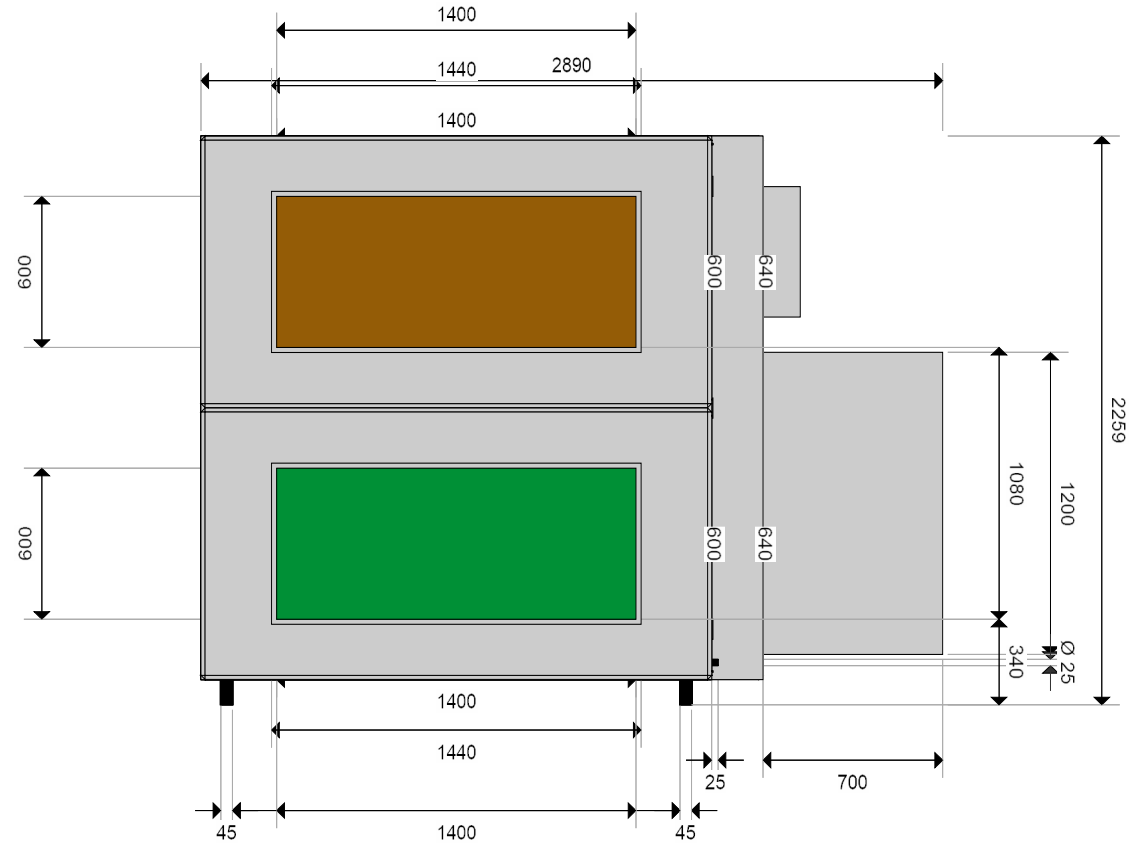

GOLD F CX	
Unit size	035
Unit weight	2,813 kg
Duct Component Weight	64 kg
Length, max	4,745 mm
Height, max	2,259 mm
Width, max	2,890 mm

Connection size	
outdoor air	1,400 x 600 mm
supply air	1,400 x 600 mm
extract air	1,400 x 600 mm
exhaust air	1,400 x 600 mm

Project: VZT  
 Unit name: AHU4 - Integrovaný  
 DX+Glykolový okruh  
 Unit ID: AD-10001019410  
 24 / 1.0.20211027.1204652  
 Date: 31/10/2021

- Outdoor air
- Supply air
- Extract air
- Exhaust air





AHU Design  
Sketch: Right-hand

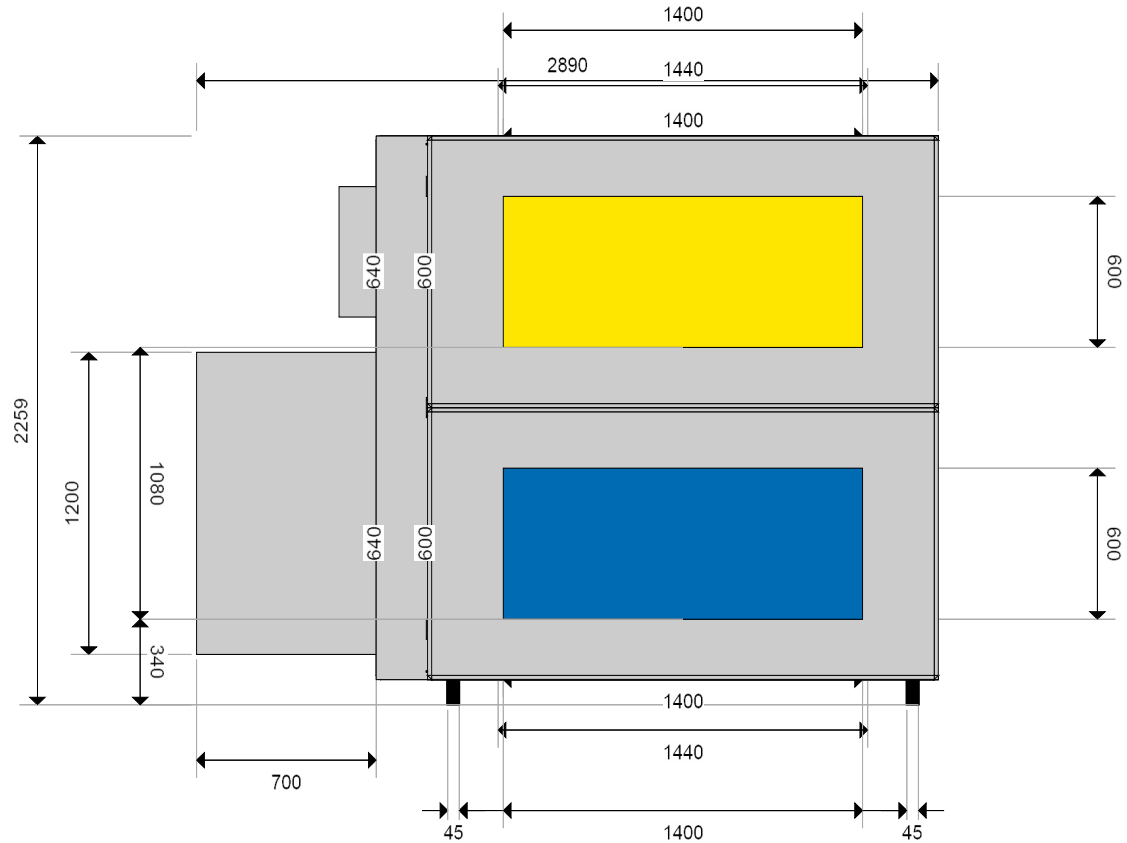

GOLD F CX	
Unit size	035
Unit weight	2,813 kg
Duct Component Weight	64 kg
Length, max	4,745 mm
Height, max	2,259 mm
Width, max	2,890 mm

Connection size	
outdoor air	1,400 x 600 mm
supply air	1,400 x 600 mm
extract air	1,400 x 600 mm
exhaust air	1,400 x 600 mm

Project: VZT  
 Unit name: AHU4 - Integrovaný  
 DX+Glykolový okruh  
 Unit ID: AD-10001019410  
 24 / 1.0.20211027.1204652  
 Date: 31/10/2021

- Outdoor air
- Supply air
- Extract air
- Exhaust air



AHU Design  
Sketch: Above

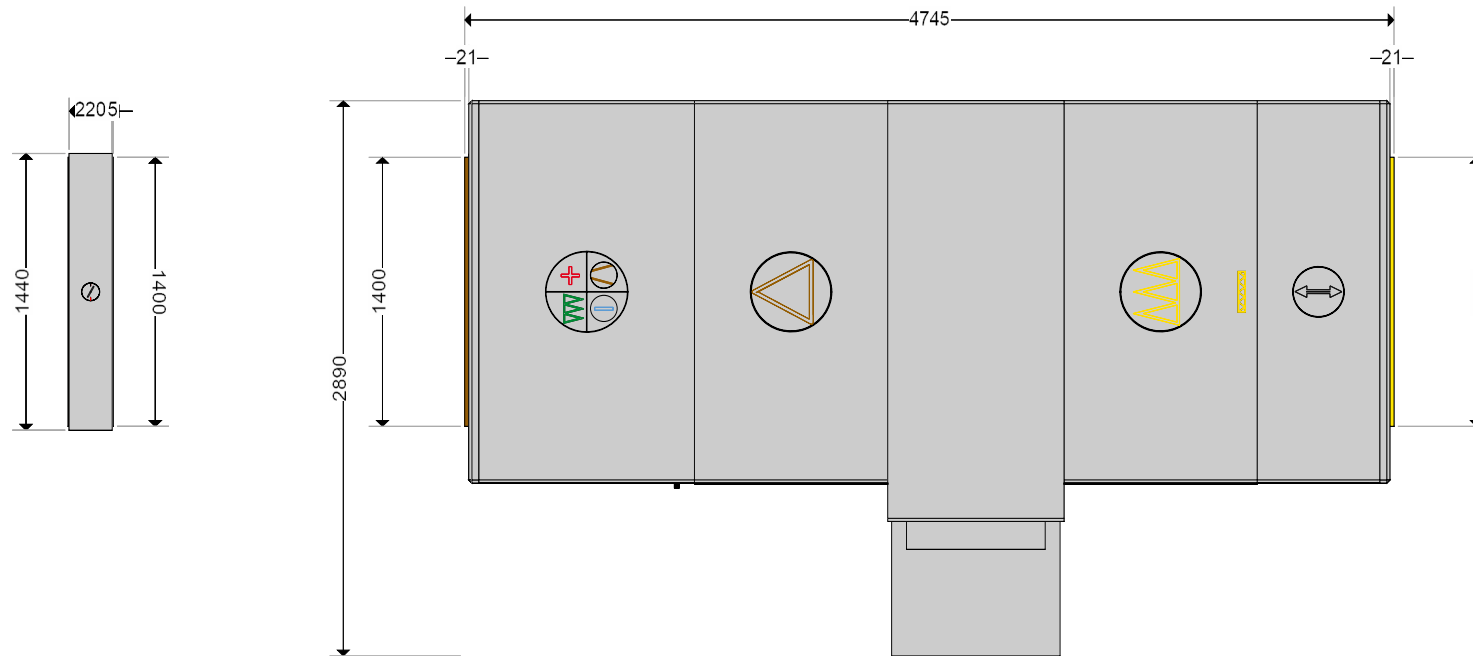

**GOLD F CX**

Unit size	035
Unit weight	2,813 kg
Duct Component Weight	64 kg
Length, max	4,745 mm
Height, max	2,259 mm
Width, max	2,890 mm

**Connection size**

outdoor air	1,400 x 600 mm
supply air	1,400 x 600 mm
extract air	1,400 x 600 mm
exhaust air	1,400 x 600 mm

Project: VZT

Unit name: AHU4 - Integrovaný

DX+Glykolový okruh

Unit ID: AD-10001019410

24 / 1.0.20211027.1204652

Date: 31/10/2021

- Outdoor air
- Supply air
- Extract air
- Exhaust air



AHU Design  
Sketch: Above left

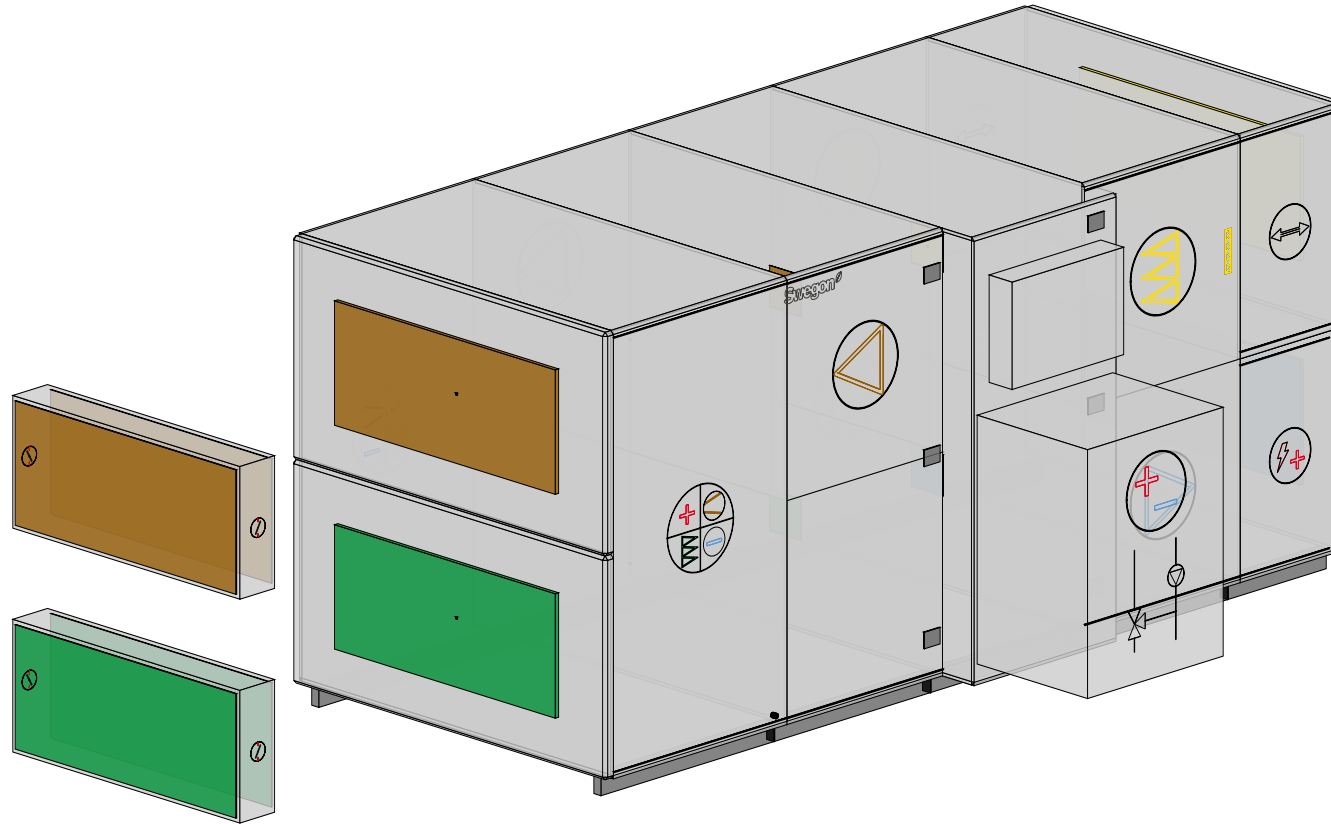

GOLD F CX	
Unit size	035
Unit weight	2,813 kg
Duct Component Weight	64 kg
Length, max	4,745 mm
Height, max	2,259 mm
Width, max	2,890 mm

Connection size	
outdoor air	1,400 x 600 mm
supply air	1,400 x 600 mm
extract air	1,400 x 600 mm
exhaust air	1,400 x 600 mm

Project: VZT  
 Unit name: AHU4 - Integrovaný  
 DX+Glykolový okruh  
 Unit ID: AD-10001019410  
 24 / 1.0.20211027.1204652  
 Date: 31/10/2021

- Outdoor air
- Supply air
- Extract air
- Exhaust air



AHU Design  
Sketch: Above right

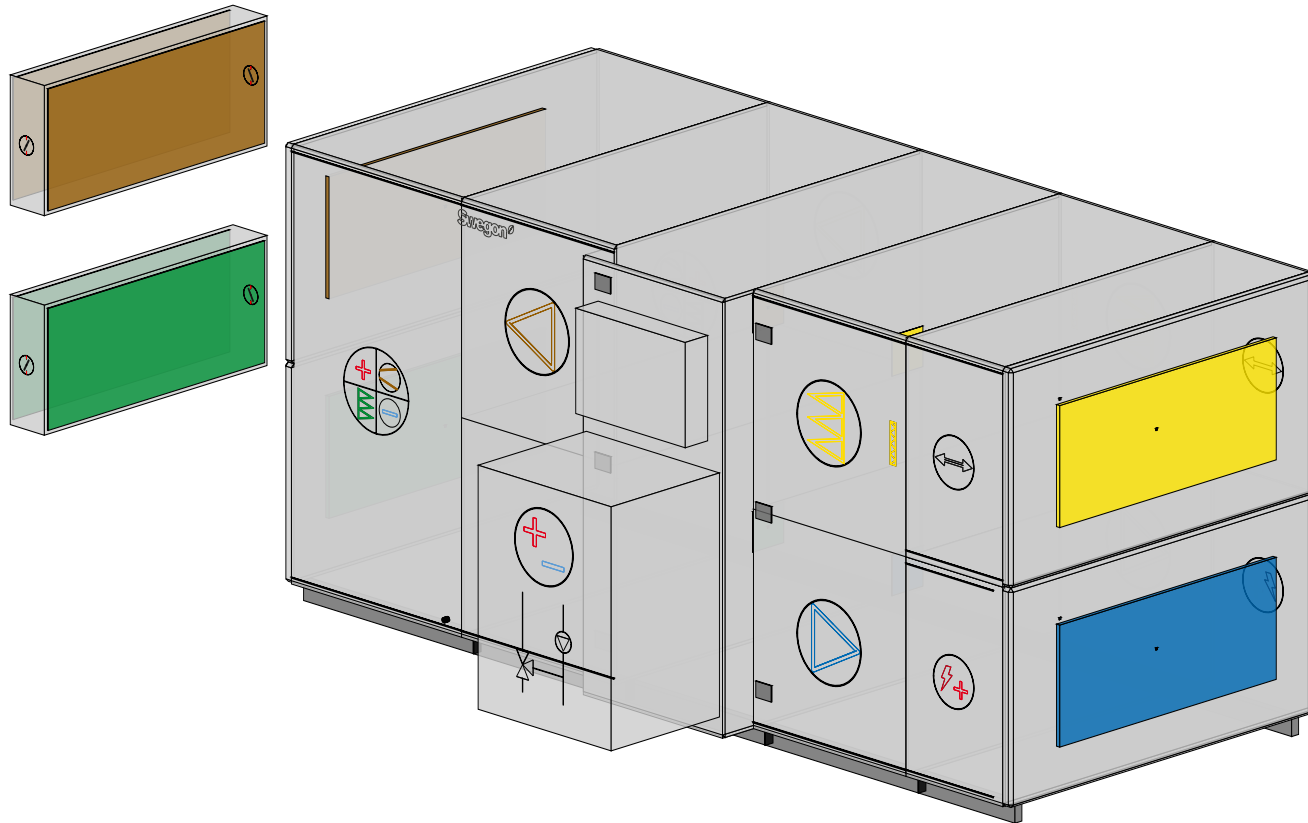

GOLD F CX	
Unit size	035
Unit weight	2,813 kg
Duct Component Weight	64 kg
Length, max	4,745 mm
Height, max	2,259 mm
Width, max	2,890 mm

Connection size	
outdoor air	1,400 x 600 mm
supply air	1,400 x 600 mm
extract air	1,400 x 600 mm
exhaust air	1,400 x 600 mm

Project: VZT  
 Unit name: AHU4 - Integrovaný  
 DX+Glykolový okruh  
 Unit ID: AD-10001019410  
 24 / 1.0.20211027.1204652  
 Date: 31/10/2021

- Outdoor air
- Supply air
- Extract air
- Exhaust air



Flow chart

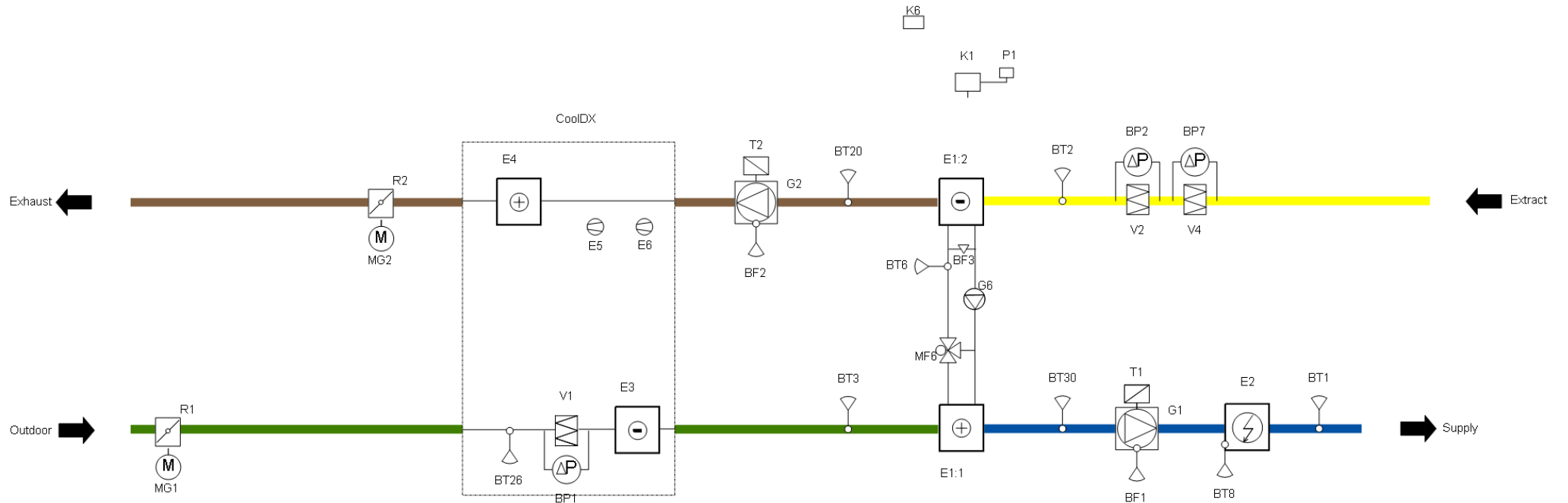

NO.	CHANGE	SIGN.	DATE



Project: VZT  
 Unit name: AHU4 - Integrovaný  
 DX+Glykolový okruh  
 Unit ID: AD-10001019410  
 Wiring Instruction

ORDER NUMBER		DRAWING NUMBER	
DESIGNED BY	Ing. Jozef Kascak	DRAW BY	PAGE
DATE	31/10/2021	REV.	CONT.
			0
			1

Project: VZT  
Unit name: AHU4 - Integrovaný DX+Glykolový okruh

Date: 31/10/2021  
24 / 1.0.20211027.1204652  
Unit ID: AD-10001019410

BF1	Airflow pressure sensor
BF2	Airflow pressure sensor
BF3	Airflow pressure sensor
BP1	Filter pressure sensor
BP2	Filter pressure sensor
BP7	Filter pressure sensor
BT1	Temperature sensor, duct
BT2	Temperature sensor Extract Air
BT20	Temperature sensor, duct
BT26	Temperature sensor, duct
BT3	Temperature sensor, duct
BT30	Temperature sensor, duct
BT6	Temperature sensor, heat exchanger
BT8	Heat protection
E1:1	Coil heat exchanger, supply air
E1:2	Coil heat exchanger, extract air
E2	Heating coil, electric
E3	Air cooler, direct expansion
E4	Condenser coil
E5	Compressor
E6	Compressor
G1	Supply fan, Wing+
G2	Extract fan, Wing+
G6	Circulation pump
K1	Control box IQlogic
K6	Functions module
MF6	Valve actuator
MG1	Damper actuator
MG2	Damper actuator
P1	Hand terminal
R1	Outdoor air damper
R2	Exhaust air damper
T1	Motor control
T2	Motor control
V1	Supply air filter
V2	Extract air filter
V4	Pre-filter, extract air

Project: VZT  
Unit name: AHU4 - Integrovaný DX+Glykolový okruh

Date: 31/10/2021  
24 / 1.0.20211027.1204652  
Unit ID: AD-10001019410

---

## Function summary

Air Handling System GOLD CX with Coil heat exchanger, Supply- and Extract Air fan Wing+ including completely integrated control system IQlogic.

The desired settings can be entered in the hand-held micro terminal, where current in-service readings are also shown.

## Controls

Sequential start-up  
Damper with motor, outdoor air duct, spring return  
Damper with motor, exhaust air duct, spring return

## Constant air flow regulation, supply air

## Constant air flow regulation, extract air

## Density-corrected air flow

## Supply air temp. regulation

## Heating sequence

- Coil heat exchanger
- Heating coil
- Heating coil, electric
- Overheating thermostat
- Prolonged fan operation to cool the el. air heater

## Functions

Zero point calibration

## Alarm monitoring

Filter monitoring  
Temperature monitoring  
Service period

## Energy monitoring

## Other

Logging function  
Wifi connection to WLAN

Project: VZT  
Unit name: AHU4 - Integrovaný DX+Glykolový okruh

Date: 31/10/2021  
24 / 1.0.20211027.1204652  
Unit ID: AD-10001019410

## Controls

GOLD is controlled via Hand Terminal P1 which is a 7" touch screen with an intuitive user interface and information help texts.

Settings and readings for included components in GOLD are presented in a flow chart on the screen.

All settings and readings are expressed in real values, such as temperatures in °C; airflows optional in m<sup>3</sup>/s, m<sup>3</sup>/h or l/s and pressure in Pascal.

When starting the GOLD, extract fan G2 is started and heat exchanger E1 is forced to max. recovery

Then, as a preset delay, the supply fan G1 starts.

Supply fan G1 and extract fan G2 are inter locked

Damper actuator MG1 closes the outdoor air damper R1 when GOLD stops, and if power fails.

Damper actuator MG2 closes the exhaust air damper R2 when GOLD stops, and if power fails.

## Constant air flow regulation, supply air

Flow pressure sensor BF1 keeps the constant supply air flow via motor controller T1.

Via the hand terminal P1 the required flow for low- and high speed for supply air is set.

## Constant air flow regulation, extract air

Flow pressure sensor BF2 keeps the constant extract air flow via motor controller T2.

Required flow for low and high extract air fan operation mode is set via hand terminal P1.

## Density-corrected air flow

The air flow is density corrected and automatically compensates for increased air density at low temperatures via outdoor sensors BT20 and BT30.

## Supply air temp. regulation

Temperature sensor BT1 keeps the supply air temperature constant according to the following control sequence.

Via hand terminal P1 the required temp set value is set.

Night compensation of temperature setpoint according to set temperature reduction. Via hand terminal P1, the desired setpoint setting and time channels for active night shift night and weekend are set.

### Control sequence if heating is required:

- Valve actuator MF6 steplessly opens the valve for the coil heat exchanger to max. recovery via function module K6

Circulation pump G6 starts when energy recovery is required.

Circulation pump G6 is pressure controlled via flow pressure sensor BF3. The flow of liquid through the coil heat exchanger is optimized taking into account the air flow of the GOLD unit to provide optimal temperature efficiency.

During other periods, the circulation pump G6 is periodically exercised at regular time intervals.

- Electrical power is modulated out to heater coil E2.

Overheating thermostat BT8 disconnects the electric heater E2 and stops the GOLD.

When the GOLD stops the fans continue for 3 minutes to cool the air heater E2.

### Control sequence if cooling is required:

- CoolDX cooling system starts for control of cooling energy to cooling coil E3.

Cooling compressors E5 and E6 control the cooling in three binary steps.

There is a settable neutral zone between the cooling and heating

## Anti-frost protection coil heat exchanger

Temperature sensor BT6 limits the water temp. in the coil heat exchanger to the minimum permissible setting by steplessly closing the valve actuator MF6 if freezing is likely.

Temperature/humidity sensor BT2/BM2 calculates the dew point in the extract air and offsets the min. limit temperature depending on the moisture content of the extract air.

## Zero point calibration

The zero point value is checked on all connected pressure sensors. If the value doesn't tally, a new calibration is made.

The function is automatically switched in each time the fans have been stopped for more than 75 seconds.



Project: VZT  
Unit name: AHU4 - Integrovaný DX+Glykolový okruh

Date: 31/10/2021  
24 / 1.0.20211027.1204652  
Unit ID: AD-10001019410

---

## Alarm monitoring

The alarm can be seen in clear text on the hand terminal P1, where even re-setting of the alarm is done.

Alarm priority A or B can be chosen for all alarms. The alarm's function, if it is to stop the GOLD or not, is chosen individually for each alarm. Safety alarms always stop the GOLD.

## Filter monitoring

Pressure sensor BP1 continually measures the pressure drop across filter V1.

Pressure sensor BP7 continuously measures the pressure drop across pre-filter V4.

The alarm limit is calculated continuously and is changed automatically dependent on the actual flow. When the set alarm value is reached the alarm is activated. The alarm limit for each filter is set in the hand terminal P1.

## Temperature monitoring

Temperatures on temp. sensors BT1 and BT2/BM2 are monitored continuously. Alarm is given if the temp. goes below set limits. The required Alarm values are set in Hand Terminal P1

The alarm is delayed 20 minutes.

## Service period

When the set service time is reached an alarm is given. After the service the next service period is set via hand terminal P1.

## Reading

Actual working value is shown in the hand terminal P1.

Temperatures

- Temperature readings on all connected temperature sensors.

- Set and actual set value.

Supply- and extract fan:

- Flow / pressure

- Set and actual set value.

- Working level

- Output

- Power.

- SFP-value.

Filter

- Current pressuredrop as well as calculated and set alarm limit.

Control sequence:

- All activated and connected control sequences.

- All connected valve actuators are equipped with valve response that indicates the valve position and gives an alarm at differing valve position.

Input and output connections:

- Current status.

Operating periods:

- Supply and extract air fans.

- Heat exchanger.

Alarms:

- Alarm history with date and time of activation and reset for the last 50 alarms

- Current alarm without time delay.

All other settings are also shown in the hand terminal.

## Energy monitoring

Actual working value is shown in the hand terminal P1.

Fan power and energy consumption.

Air handling unit total energy consumption.

## Manual test

Provision is available for testing and checking internal components in GOLD unit. Fans, heat exchanger, inputs and outputs and the connected accessories can be tested individually.

## Logging function

Project: VZT  
Unit name: AHU4 - Integrovaný DX+Glykolový okruh

Date: 31/10/2021  
24 / 1.0.20211027.1204652  
Unit ID: AD-10001019410

---

Via control system multi-media card the parameter values are logged and saved for the systems log function. Parameter values can be forwarded or uploaded as an Excel file.

On a specific log page in the Hand Terminal one or several parameters can be chosen, to be read in a diagram with a time axis and a size axis. The parameters can be read in real time or as a logged value.

## Communication

GOLD is controlled and monitored via standard web browser. Control system IQlogic contains a web server with a dynamic flow chart including operation and functions pages. Alarms are forwarded via built-in mail function.

## WiFi

Control unit K1 is equipped with an antenna for connection to WLAN and direct connection to Portable Computers or Smart phone. Where the same functionality and visualization is given as in the Hand Terminal P1

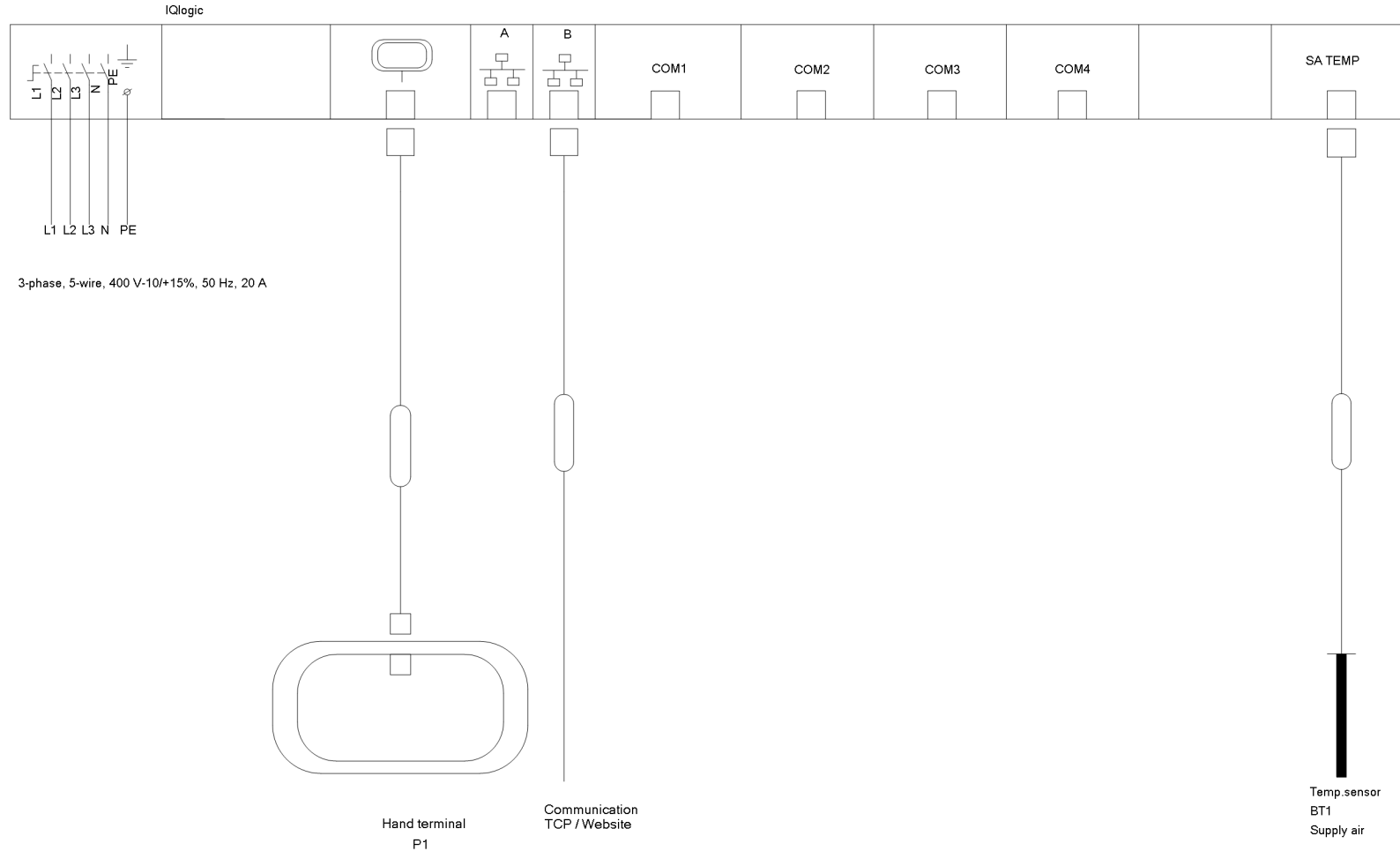

NO.	CHANGE	SIGN.	DATE



Project: VZT  
 Unit name: AHU4 - Integrovaný  
 DX+Glykolový okruh  
 Unit ID: AD-10001019410  
 Wiring Instruction

ORDER NUMBER		DRAWING NUMBER	
DESIGNED BY Ing. Jozef Kascak		DRAW BY	PAGE 1
DATE 31/10/2021		REV.	CONT. 2

NOTE:  
Terminal 20-25: Max 5A, 250V AC

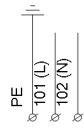

GOLD IQlogic

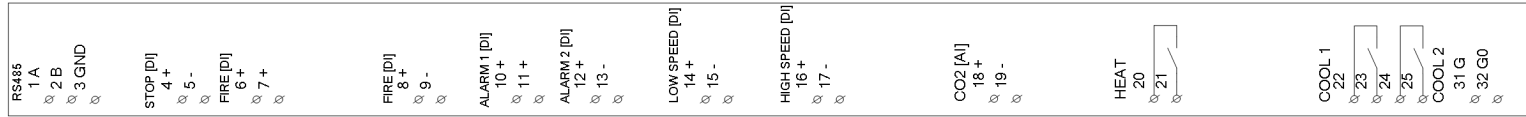

NO.	CHANGE	SIGN.	DATE



Project: VZT  
Unit name: AHU4 - Integrovaný  
DX+Glykolový okruh  
Unit ID: AD-10001019410  
Wiring Instruction

ORDER NUMBER		DRAWING NUMBER	
DESIGNED BY Ing. Jozef Kascak	DRAW BY	PAGE 2	
DATE 31/10/2021	REV.	CONT. 3	

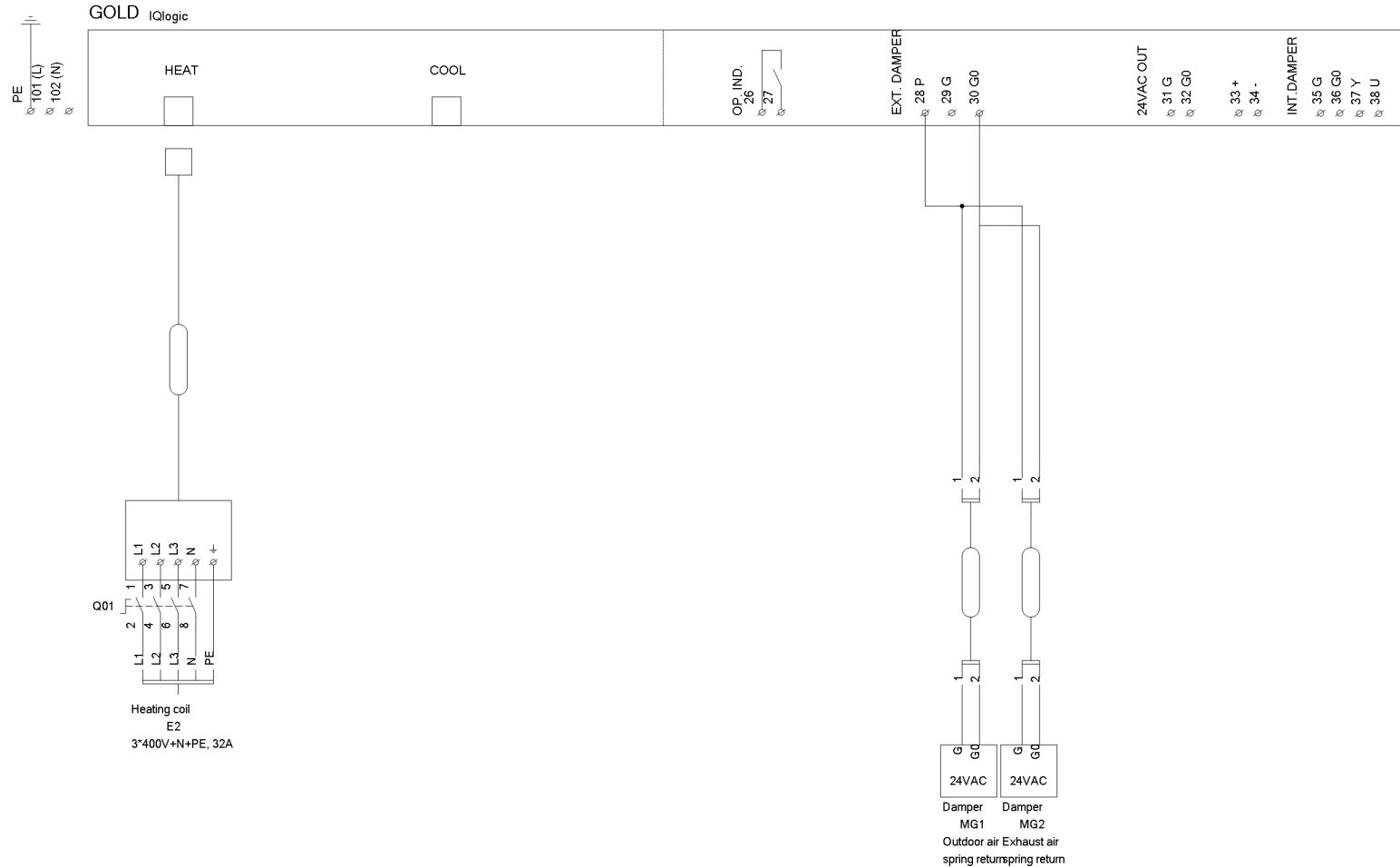

NO.	CHANGE	SIGN.	DATE



Project: VZT  
 Unit name: AHU4 - Integrovaný  
 DX+Glykolový okruh  
 Unit ID: AD-10001019410  
 Wiring Instruction

ORDER NUMBER		DRAWING NUMBER	
DESIGNED BY Ing. Jozef Kascak	DRAW BY	PAGE 3	
DATE 31/10/2021	REV.	CONT. 4	

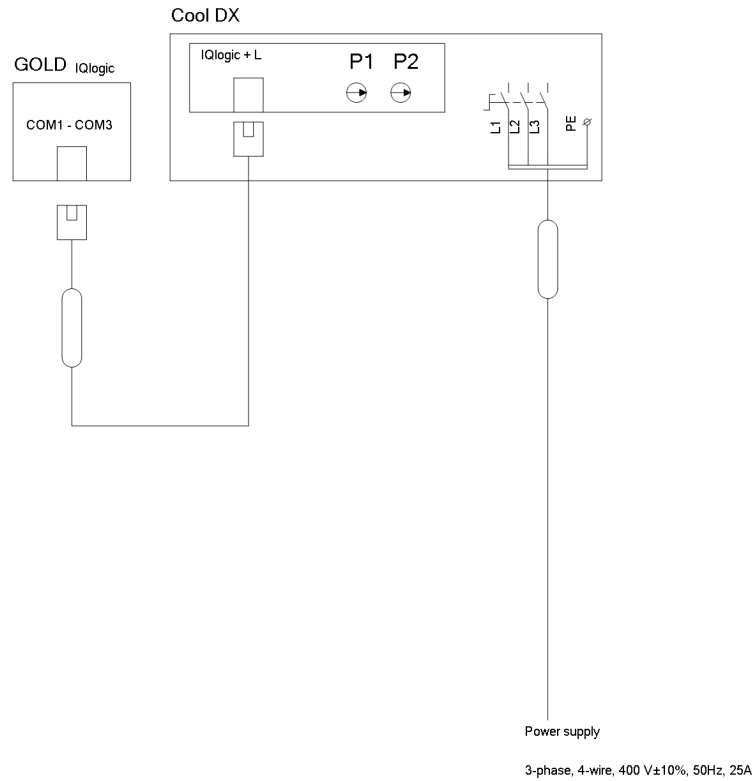

NO.	CHANGE	SIGN.	DATE



Project: VZT  
 Unit name: AHU4 - Integrovaný  
 DX+Glykolový okruh  
 Unit ID: AD-10001019410  
 Wiring Instruction

ORDER NUMBER		DRAWING NUMBER	
DESIGNED BY Ing. Jozef Kascak	DRAW BY	PAGE 4	
DATE 31/10/2021	REV.	CONT.	

Project: VZT  
Unit name: AHU4 - Integrovaný DX+Glykolový okruh

Date: 31/10/2021  
24 / 1.0.20211027.1204652  
Unit ID: AD-10001019410

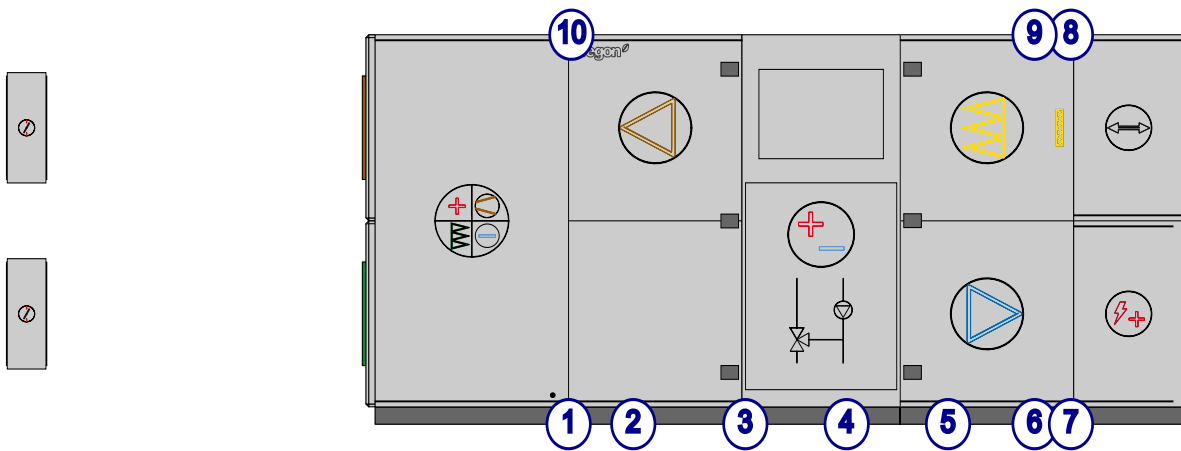

Components are arranged according to airflow direction  
Dimensions are written as L \* W \* H

	Outdoor air
	Supply air
	Extract air
	Exhaust air

Number	Name	Dimensions	Volume	Internal weight	Total weight
1	End section	52*1990*1078 mm	0,11 m <sup>3</sup>	33 kg	33 kg
2	Cooling machine, DX	1100*1990*2259 mm	4,94 m <sup>3</sup>	484 kg	484 kg
3	Filter			5 kg	
	Fan	987*1990*2259 mm	4,44 m <sup>3</sup>	87 kg	377 kg
4	Coil heat exchanger	900*2190*2959 mm	5,83 m <sup>3</sup>	875 kg	1,200 kg
5	Fan			87 kg	
	Filter	987*1990*2259 mm	4,44 m <sup>3</sup>	18 kg	390 kg
6	Heating coil, electrical, in casing	625*1990*1179,5 mm	1,47 m <sup>3</sup>	39 kg	137 kg
7	End section	52*1990*1078 mm	0,11 m <sup>3</sup>	33 kg	33 kg
8	End section	52*1990*1078 mm	0,11 m <sup>3</sup>	33 kg	33 kg
9	Spacer section	625*1990*1179,5 mm	1,47 m <sup>3</sup>	0 kg	94 kg
10	End section	52*1990*1078 mm	0,11 m <sup>3</sup>	33 kg	33 kg
					2,813 kg

Project: VZT  
Unit name: AHU4 - Integrovaný DX+Glykolový okruh

Date: 31/10/2021  
24 / 1.0.20211027.1204652  
Unit ID: AD-10001019410

## QAB Air Handling Unit

### Supply and Extract

#### General

The Air Handling Unit shall be of type GOLD CX

The unit shall be delivered complete with direct-drive supply and / or exhaust air fans with PM / EC motors, energy class IE4, for continuous operation at temperatures up to 40 ° C. The fan, including motor and drive unit, shall be tested and approved for operation at a temperature of 70 ° C for at least one hour.

Energy recovery is to be achieved by a high efficiency liquid coupled heat exchanger (CX)

The Manufacturer will be ISO9001 and ISO14001 Certified.

The control function of each unit shall be tested in the factory at the end of production.

#### Regulation, operation and visual presentation

The unit shall be supplied with complete, factory-mounted, integrated and digital control equipment. The control equipment is manually operated from an easy-to-understand wired, alternatively WLAN-enabled handheld terminal containing a capacitive 7-inch touchscreen.

The control function of each unit shall be tested in the factory at the end of production. The control functionality shall be standard, industrialised, tested and fully documented with comprehensive customer support.

The values in the handset shall be displayed dynamically in a flow image. The handset also displays help and function texts to facilitate operation and describe functionality.

The unit will be supplied with a built-in web server for monitoring and operation via TCP / IP connectivity. The web server shall mimic the handset's structure and dynamically display the values in a flow image. WLAN shall be used for connection to laptop, tablet or smartphone with the same functionality and interfaces given as in handheld and web server.

The unit shall be prepared to be controlled and monitored via cloud service connected to the Internet or mobile network. Mobile network connection is via subscription.

All settings and readings are made in real values, eg temperature in ° C and pressure in Pascal. Flow unit shall be selectable to m<sup>3</sup> / s, m<sup>3</sup> / h or l / s.

#### Unit data logging

The unit shall be delivered with integrated logging function with display in the hand terminal or web page, and with the ability to automatically transfer the values to another system for compilation. Data can be read in real time or as historical logged data.

#### Energy monitoring

The unit's energy consumption shall be readable in real terms, eg kW, kWh and current SFP figures. Recovered energy from rotary heat exchanger shall be given in kW and kWh. Ev. leakage and purge flows shall be readable in the hand terminal.

#### Functions

At startup of the unit, the exhaust air fan and heat exchanger shall be started first with energy recovery forced to maximum. Where a heating coil is installed, it is preheated in parallel with the heat exchanger. After a time delay, the supply air fan shall be started.

The unit controller shall be factory programmed with software that regulates temperatures, airflows and all other functionality. It shall be easy to activate or change standard functionality by means of the HMI.

Alarms shall be reported and reset in plain text in the HMI.

Alarm priority A or B can be selected for all alarms. The function of the alarm, if it is to stop the unit or not, is individually selected for the respective alarms. Safety alarm always stops the unit.

The unit shall be delivered with function for seasonally adjusted flow control. This function is used to reduce the operating cost of fans, post heating in the supply air and the building's regular heating system.

The unit shall be delivered with density-corrected airflow function so that the pressure balance in the building is automatically maintained at the correct level throughout the year.



Project: VZT  
Unit name: AHU4 - Integrovaný DX+Glykolový okruh

Date: 31/10/2021  
24 / 1.0.20211027.1204652  
Unit ID: AD-10001019410

---

To ensure optimal energy use, a continuous final pressure drop for the unit's filters shall be automatically calculated in relation to the current airflow. On reaching the final pressure drop, an alarm shall be issued to initiate a demand-controlled exchange of filters.

The zero point value is automatically calibrated on all connected pressure sensors each time the fans are started after a stop exceeded 75 seconds. If the value does not match, the process is repeated.

The service period shall be adjustable. An alarm shall be issued if the set service period is exceeded. After a service, the service interval shall be automatically reset.

It shall be possible to test and check the individual components of the unit via manual setting in the hand terminal. Fans, heat exchanger, inputs and outputs and connected accessories shall be tested separately.

## Accessories

All other unit component accessories such as damper, air heater, air cooler etc. mounted in the duct system and appropriately connected to the unit controller using quick connectors.

The control functions necessary to control the accessories shall be included in the controller software as standard.

## Certification

Air handling units shall be certified according to Eurovent, No. AHU-06-06-319, and comply with the Ecodesign Directive (EU) 1253/2014.

The unit shall be CE marked in the factory and comply with the Machine Directive as well as the EcoDesign, RED and PED Directives

The unit shall be Passive House certified for an airflow of up to 9000 m<sup>3</sup> / h.

## Mechanical construction

The unit shall be made of self-supporting cover panels and inspection doors in sandwich construction with a minimum of 52mm thickness with 50mm of mineral wool insulation. Rigid foam shall not be used in the panels. The exterior sheet shall be galvanized steel with a grey metallic coating RAL 9007. The inner sheet shall be aluzink-treated sheet steel.

The unit shall meet corrosion class C4, inside and outside, according to SS-EN ISO 12944-2. The casing shall comply with the requirements for casing strength D1, tightness class L2, cold bridge TB2 and heat transmission T2 according to EN 1886: 2007.

Leakage class L2 shall be met also by the internal separation between air flows. Inspection doors shall be hung on adjustable hinges and fitted with integrated and flush mounted handle that opens in 2 steps for personal safety and pressure equalization. The handles shall have locks with common keys.

The entire unit shall be designed for the temperature range -40°C and +40°C.

All cabling in the unit shall be PVC/halogen free.

The Unit will be of construction that will allow ease of access through the Building or have the facility to be flat-packed and rebuilt.

The fan impellor and it's motor shall be balanced together to grade G 6,3 enl ISO 1940-1 and shall be isolated from the unit casing by means of rubber anti vibration mounts and flexible connection. The fans shall be mounted on rails and shall be easily withdrawable. Fans shall be fitted with an airflow measuring device with readout of the airflow rate in the HMI with a tolerance of +/- 5%

Filters shall meet the requirements of EN ISO 16890:2016 and each filter shall be marked with the relevant classification.

## Communication

The unit control shall have the facility to connect to a BMS system (SCADA system). The controller shall be ready for data communication with protocols BACnet IP and ModBus TCP / RTU and all necessary documentation shall be readily available.